



APPLICATION

Francis Searchlights are a major supplier of lighting equipment to the worlds emergency services and emergency vehicle manufacturers

The FB230 is vehicle mounted, but is fitted on a detachable base. When used in conjunction with the optional tripod and cable reel this allows the searchlight to be operated at up to 90 meters away from the vehicle.

Further options are "clip on" colour filters and a heavy duty flasher / interrupter unit, which, when operated allows the searchlight to be used as a long distance warning device.

SPECIFICATION

- Toughened super clear Optiwhite front glass.
- Parabolic glass reflector
- Constructed from marine grade materials and fixings
- Powder coated and stove enamel paint finish, optional chrome.
- Pan rotation 450°
- Integral on / off switch.
- Deck Tilt elevation control +90° to -40°.
- Optional Heater fitted in barrel
- Tungsten halogen lamp
- Light shield to prevent unwanted glare & stray light
- External lamp focus, 2° spot to 5° flood.
- Sealing – IP56 Searchlight
- Searchlight weight 6.2kgs.

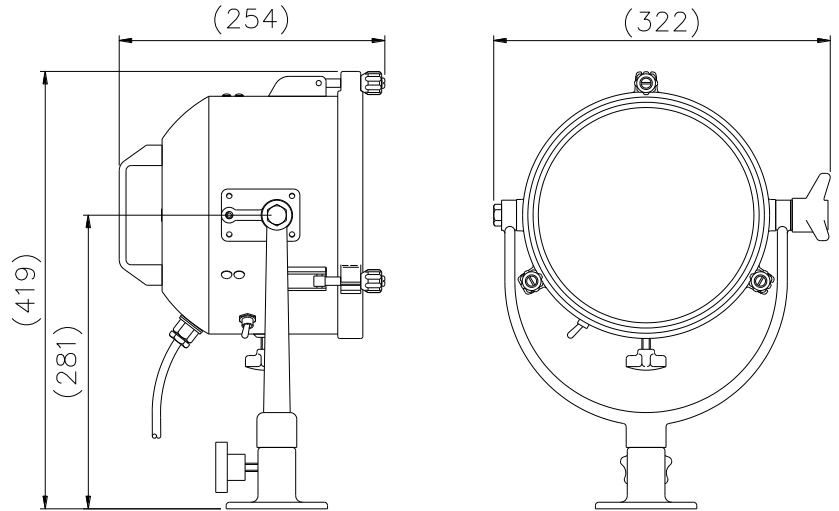

ALL DIMENSIONS IN MILLIMETRES

Base fixing details:
Deck 3 holes Ø8 equi-spaced on a 81.0 PCD

Part Numbers

Type	Finish	Supply	Part No
FB230	Chrome	12/24v	B7162
FB230	Black	12/24v	B7168
FB230	Chrome	115/230v	B7181
FB230	Black	115/223v	B7174

Accessories & Additional Parts:

Portable Tripod	B7007
30m Cable Reel c/w Cable LV	B7001
45m Cable Reel c/w Cable LV	B7002
90m Cable Reel c/w Cable LV	B7003
30m Cable Reel c/w Cable HV	B7004
40m Cable Reel c/w Cable HV	B7005
80m Cable Reel c/w Cable HV	B7006
Red Filter Assy	C14938-01
Amber Filter Assy	C14938-01
Blue Filter Assy	C14938-01
Green Filter Assy	C14938-01
Clear Filter Assy	C14942-01
12v Interrupter Unit	B7016
24v Interrupter Unit	B7017

VAC	Lamp life	Range @ 1 Lux	PBCP X 1000	Div	Watts	Lamp No
12v	2000 hrs	643m	414	2°	100w	D9848
24v	300 hrs	784m	614	2°	150w	D14795
24v	2000 hrs	910m	828	2°	250w	D4695
24v	300 hrs	1095m	1200	2°	250w	D9851
120v	150 hrs	912m	832	4.9°	300w	D16883
230v	75 hrs	888m	790	4.9°	300w	D16841

For more information contact: