



**FB280 Issue 5
Halogen, Deck
Control Emergency**

APPLICATION

Francis Searchlights are a major supplier of lighting equipment to the worlds emergency services and emergency vehicle manufacturers

The FB280 is vehicle mounted, but is fitted on a detachable base. When used in conjunction with the optional tripod and cable reel this allows the searchlight to be operated at up to 90 meters away from the vehicle.

Further options are "clip on" colour filters and a heavy duty flasher / interrupter unit, which, when operated allows the searchlight to be used as a long distance warning device.

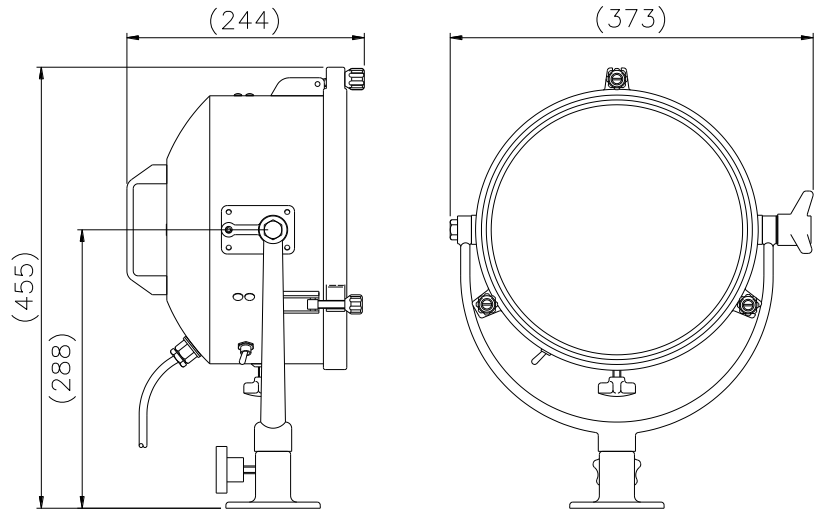

SPECIFICATION

- Toughened super clear Optiwhite front glass.
- Parabolic glass reflector
- Constructed from marine grade materials and fixings
- Powder coated and stove enamel paint finish, optional chrome.
- Pan rotation 450°
- Integral on / off switch.
- Deck Tilt elevation control +90° to -40°.
- Optional Heater fitted in barrel
- Tungsten halogen lamp
- Light shield to prevent unwanted glare & stray light
- External lamp focus, 2° spot to 5° flood.
- Sealing – IP56 Searchlight
- Searchlight weight 7.4kgs.

ALL DIMENSIONS IN MILLIMETRES

Base fixing details:
Deck 3 holes Ø8 equi-spaced on a 81.0 PCD

Part Numbers

Type	Finish	Supply	Part No
FB280	Chrome	12/24v	B7163
FB280	Black	12/24v	B7169
FB280	Chrome	115/230v	B7186
FB280	Black	115/223v	B7179

Accessories & Additional Parts:

Portable Tripod	B7007
30m Cable Reel c/w Cable LV	B7001
45m Cable Reel c/w Cable LV	B7002
90m Cable Reel c/w Cable LV	B7003
30m Cable Reel c/w Cable HV	B7004
40m Cable Reel c/w Cable HV	B7005
80m Cable Reel c/w Cable HV	B7006
Red Filter Assy	C14943-01
Amber Filter Assy	C14944-01
Blue Filter Assy	C14945-01
Green Filter Assy	C14946-01
Clear Filter Assy	C14947-01
12v Interrupter Unit	B7016
24v Interrupter Unit	B7017

VAC	Lamp life	Range @ 1 Lux	PBCP X 1000	Div	Watts	Lamp No
12v	2000 hrs	933m	871	3°	100w	D9848
24v	300 hrs	960m	921	3°	150w	D14795
24v	2000 hrs	1114m	1242	3°	250w	D4695
24v	300 hrs	1342m	1800	3°	250w	D9851
120v	150 hrs	1150m	1323	4.7°	300w	D16883
230v	75 hrs	1118m	1250	4.7°	300w	D16841

For more information contact:

Francis Searchlights Limited
 Union Road, Bolton, BL2 2HJ, UK
 Tel 44 (0) 1204 558960 Fax 44 (0) 1204 558979
 Email sales@francis.co.uk Web site www.francis.co.uk