



**FB280 Issue 4
Tungsten Halogen
Deck Control - Emergency**

APPLICATION

Francis Searchlights are a major supplier of lighting equipment to the worlds **emergency services and emergency vehicle manufacturers**

The **FB280** is vehicle mounted, but is fitted on a detachable base. When used in conjunction with the optional tripod and cable reel this allows the searchlight to be operated at up to 90 metres away from the vehicle.

Further options are "clip on" colour filters and a heavy duty flasher / interrupter unit, which, when operated allows the searchlight to be used as a long distance warning device.

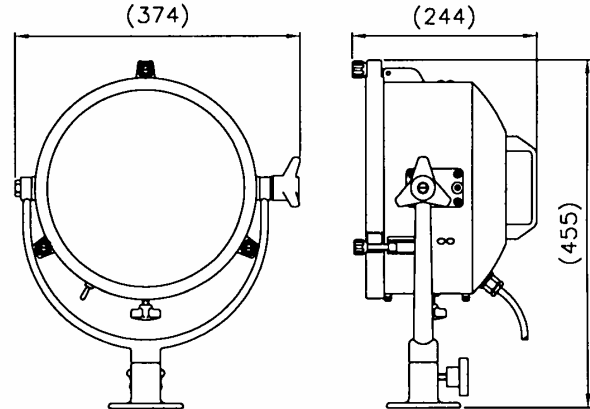

All dimensions in Millimeters

Base fixing details

3 holes \varnothing 8 equi-spaced on a 81.0 P.C.D.

Weight – 7.4 Kg

PART NUMBERS			
Type	Supply	Finish	Part No.
FB280	12/24v	Chrome	B7163
FB280	12/24v	Black	B7169
FB280	110/230v	Chrome	B7186
FB280	110v/230v	Black	B7179

SPECIFICATION

- Constructed from Marine grade materials and fixings.
- Stove enamel paint or chrome finish.
- Toughened front glass.
- Parabolic, lead backed, glass reflector.
- Tungsten Halogen light source 12/24v or 110/220v
- External lamp focus adjustment.
- Integral on / off switch.
- Captive bezel / glass.
- Light shield to prevent unwanted glare & stray light.
- Enclosure protection to IP56.
- Lamp focus is adjustable between 3° spot and 5° flood.

ACCESSORIES & ADDITIONAL EQUIPMENT

Description	Despatch No.
Portable Tripod	B7007
30 Metre cable reel LV	B7001
45 Metre cable reel LV	B7002
90 Metre cable reel LV	B7003
Red filter Assy	C14943-01
Amber filter Assy	C14944-01
Blue filter Assy	C14945-01
Green filter assy	C14946-01
Clear filter assy	C14947-01
12v Interrupter unit	B7016
24v Interrupter unit	B7017
30 M cable reel HV	B7004
40 M cable reel HV	B7005
80 M cable reel HV	B7006

PERFORMANCE DATE * Inclusive angle

Volts	Watts	Range @ 1 Lux	P.B.C.P. x 1000	Div. *	Lamp Life	Lamp Cap	Lamp Part Number
12v	100w	933 M	871	3.0°	2000 hrs	GX6.35	D9848
24v	150w	960 M	921	3.0°	300 hrs	GX6.35	D14795
24v	250w	1114 M	1242	3.0°	2000 hrs	GX6.35	D4695
24v	250w	1342 M	1800	3.0°	300 hrs	GX6.35	D9851
120v	300w	1150 M	1323	4.7°	150 hrs	GX6.35	D16883
230v	300w	1118 M	1250	4.7°	75 hrs	GX6.35	D16841

Francis Searchlights Limited
 Union Road, Bolton, BL2 2HJ, UK
 Tel 44 (0) 1204 558960 Fax 44 (0) 1204 558979
 Email sales@francis.co.uk Web site www.francis.co.uk

For more information contact: