



User Instruction & Installation Manual

FX560 Remote Control 2 Kilowatt Xenon Searchlight



Product Reference Number:

A2471 – Variable Speed Motor Unit 240v

A2473 – Variable Speed Motor Unit 115v

Manufacturers details:

Francis Searchlights Ltd
Union Road, Bolton
Lancashire, BL2 2HJ, UK
Tel: +44 (0) 1204 558960
Fax: +44 (0) 1204 558979
<http://www.francis.co.uk>
E-mail: sales@francis.co.uk

Distributor details:



Manual Part Number: C20244

Issue : 19

CONTENTS

- 1 - Introduction
- 2 - Safety Precautions
- 3 - Technical Information
- 4 - Unpacking and Installation Instructions
- 5 - Electrical Installation
- 6 - Operating Instructions
- 7 - Fault Finding
- 8 - Maintenance and Servicing
- 9 - General Assembly & Wiring Diagrams
- 10 - Spare Parts List

1 - Introduction

It is imperative that this manual is read carefully and understood before installing your equipment. For your future reference please keep this manual in a safe place.

Thank you for specifying a product from the Francis Searchlights range. All Francis products are designed to give complete customer satisfaction and are manufactured to the highest engineering standards in order to ensure optimum performance and service life.

The Francis Xenon range combine features proven over many years service in the most hazardous conditions in both marine and land installations.

In order to prolong the life and performance of your product, we recommend that you only specify Francis Searchlights spare parts. This will also ensure that any warranties on your equipment will not be invalidated. Information on spares ordering and parts is provided in this manual.

Should you ever need to contact Francis Searchlights Ltd. regarding your equipment, please quote the Product Serial Number at all times.

2 - Safety Precautions

The following instructions must be adhered to, in order to ensure a safe working environment and the safety of the user.

Note: When unpacking or manoeuvring the searchlight into its fixing position, suitable lifting points must be used in order to prevent damage to the equipment or personal injury.

- Because of the high internal pressure within the lamp, there is a risk of explosion in either a hot or cold state;
- During operation this lamp emits intense UV radiation which is harmful to the eyes and skin. Suitable protection should be worn;
- The high luminance of the arc can cause severe damage to the eye if viewed directly. ALWAYS wear suitable protective goggles when viewing the lamp;
- Always use protective jackets supplied with the lamp;
- Should it be necessary to examine the lamp with the front bezel removed, always use a protective shield and wear goggles to ensure a safe working environment;
- Searchlights get hot. Never touch the unit when lit and always allow 15 to 20 minutes for cooling down after turning the searchlight off;
- Never place anything on or cover the searchlight when in use;
- Ensure the lamp has cooled sufficiently before removal;
- If undue force appears necessary to remove the lamp, the equipment should be inspected by a competent person or contact the manufacturer;
- When disposing of lamps there are several options available:
 - Return the lamp, via the supplier, to the lamp manufacturer in its complete packaging
 - Because of the cold internal pressure of the lamp is approximately 8 bar, the lamp must first be depressurized before disposal. Place the lamp, in its protective jacket, in a plastic bag and drop from a height of 1 to 2 metres onto a hard surface;
- XBO lamps do not contain materials which are harmful to the environment and thus are not subject to special waste disposal regulations;
- Due to the vast range of lamps available it may appear possible that more powerful lamps can be used in the equipment than for which it was designed. Even when the unit will physically accept a higher wattage lamp, this substitution is not recommended and is dangerous. This action will also void any warranties on the equipment.
- Always refer to the lamp manufacturers technical data when dealing with lamps.

3 - Technical Information

This product has been designed to operate in accordance with the product specification. The FX560RC 2000 watt searchlight has the following features:

- All marine grade materials and fixings;
- Electronic power supply unit;
- Parabolic glass reflector;
- Stove enamel painted;
- 385° horizontal rotation;
- Vertical movement 20° to -20°;
- Motor speed 0-20°/sec fast, 0-10°/sec slow (Pan)
0-10°/sec fast, 0-5°/sec slow (Tilt);
- Remote focus facility;
- Internal self-regulating heater.

The searchlight also performs to the following optical data:

- Xenon light source;
- Lamp Wattage - 2000 Watts;
- Supply voltage – 110/120v or 220/240V;
- Peak Beam Candlepower – 108,084,800 lux;
- Range – 10,396 metres;
- Divergence - 1.5°;
- Temperature range: -50°C;

In order that the searchlight operates correctly it is imperative that competent personnel are responsible for the installation, operation and servicing of this equipment. Failure to adhere to this advice may cause premature failure or incorrect operation of the searchlight, which may damage the equipment or cause personal injury.

Technical information on the Xelamp Power Supply Unit and Irem Ignitor are included overleaf. For more detailed information please contact the manufacturer.

PSU ref: Model 8502 (Xelamp)
Ignitor ref: AS16040A (Irem)

Power Supply fixings centres 440 x 152 using M8 screws.

Power Supply Details (Model 8502)

General Description

Output	Power	1400-2200 watts	
	Voltage	22-30 volts D.C.	
	Current	50-85 amperes D.C.	
	Ripple	5% peak-to-peak	
Input	Current	25/22 amperes maximum	40 amperes maximum
	Voltage	208/237 VAC	110/120 VAC
	Phase	Single	
	Frequency	60 Hz (50Hz available)	
Output Adjustments		9 steps	
Size	Width	12" (30.5 cm)	
	Height	15" (38 cm)	
	Length	19" (48.25 cm)	
Weight		145 lbs. (65.9 Kg)	
Cooling		Convection	

Warning

When this appears in this text, it indicates a hazard to personnel.

Caution

When this appears in this text, it indicates a procedure which can result in equipment damage if not properly accomplished.

Receiving the Power supply

The units are shipped with the power supply bolted to a shipping skid and enclosed in a heavy cardboard cover held in place by banding. Physical damage to the container or its contents should be reported to the carrier immediately.

Unpacking

Cut the banding strips and lift the cardboard cover off of the unit. Remove the four bolts holding the power supply to the skid. Place the unit in the location selected for installation.

Locating the power supply

The power supply is convection cooled and the location selected should provide a minimum of 6" clearance around the case. The area should have free movement of air to dissipate the heat generated by operation of the power supply. Provide a space large enough to allow service of the unit if required.

Caution

Do not allow anything to be placed upon the power supply case; the perforated top is for ventilation and must not be obstructed.

Try to select a location as close to the lamphouse as practical. Many users install the power supply adjacent to the searchlight where space is available and local codes permit.

Electrical installation and connection

Caution

Much future grief can be avoided by having a competent electrical contractor install and connect this unit.

Caution

We make suggestions in this manual as to minimum wire sizes to be used. Refer to, and conform to the codes applicable in your area.

Caution

Observe polarity of the conductors which carry the D.C. output of the power supply to the lamphouse. Reversed polarity will immediately destroy the xenon bulb upon application of power.

Warning

When the electrical installation is complete there are two sources of primary power within the unit. Turn off all power when adjusting or servicing the power supply.

Warning

This unit can run warm to very hot. Allow at least 15 minutes after turning off the power for the unit and its components to cool down before attempting any service procedures.

Holes are provided in the end section of the power supply case for conduit entries. Install conduit in a manner which allows some movement for service if required. Refer to drawings for connection information.

Model 8502 Primary line: (240v) #10 gauge minimum (110v) #8 gauge minimum; 30 ampere breaker or fuse (240v) 40 ampere breaker or fuse (110v).
D.C. output: #4 gauge minimum.

Warning

The power supplies have two sources of power. Disconnect (turn off) primary power before making adjustments or service procedures.

Output power adjustment

Warning

The power supply stores energy after primary power is switched off. Wait a minimum of two minutes for the capacitor charge to bleed off.

Taps are provided on TB1 to alter the output of the power supply. Small current changes may be made by moving the tap from H to M to L. Highest current is on H; the lowest is on L. Larger current changes may be made by moving the tap from 4 to 5 to 6. Highest current is on 4; the lowest is on 6. One input line must be on H, M or L. The second line must be on 4, 5 or 6. When the primary line is high (120/240 VAC), tap 5 or 6 should be used. For 110/208 VAC use any tap, 4, 5 or 6. When changing taps, do not insert wire into the connector so far as to clamp on the insulation rather than the bare wire. Be sure to tighten the connector screws.

Routine maintenance

Warning

The power supply has two sources of power. Turn off power before servicing the unit.

Warning

This unit can run warm to very hot. Allow at least 15 minutes after turning off the power for the unit and its components to cool down before attempting any service procedures.

At 6 month intervals, clean dust out of the unit. Inspect all electrical connections. Look for discoloration due to overheating. Be sure all components are clean and tight.

Troubleshooting

Much data can be obtained from the volt-ammeter built into the lamphouse control panel. In addition, the following instruments will be needed to perform all trouble-shooting operations that can be done in the field:

Portable volt-Ohm-ammeter (VOM) – must be capable of supplying current to forward bias a silicon diode on R X 1 range. (Some digital instruments cannot; consult operator's manual for instrument concerned.)

Clamp-on A.C. ammeter capable of ¼ ampere or better resolution.

Xenon lamp power supplies have two stages of operation:

- 1) Before igniting the bulb – At this time, the voltage at the power supply output terminals reaches “open circuit” value (110 VDC or greater).
- 2) After igniting the bulb – At this time, the voltage at the power supply output is determined by the load placed on the power supply by the xenon lamp (18-30 VDC).

Power supply difficulties can be separated into one of three areas for purposes of diagnosis and repair:

- A) Power line problems.
- B) Boost circuit (Open circuit voltage) problems.
- C) Main power supply problems.

A) Primary power problems

Power to the power supply is supplied from the sub-panel. The PSU power contactor, K1, will operate when the lamphouse is switched on in the absence of primary power to K1. If there is D.C. voltage out of the power supply as indicted on the lamphouse voltmeter you have primary power. If there is no lamphouse voltmeter, use your VOM. If there is no DC. output voltage and K1 operates, check the primary line with a VOM to locate the point of failure.

B) Boost circuit problems (open circuit voltage)

Loss of the open circuit voltage due to boost circuit problems will result in the following:

Ignitor will not fire in the AUTO mode.

Bulb will not light.

Disable the lamphouse ignitor by removing primary power to the ignitor. Connect your VOM to the power supply D.C. output. Observe polarity. Turn on the power supply. If you read 110 VDC or more, the boost circuit is operating. If the D.C. voltage is low, on the order of 50 volts, it is likely that diodes 5 and/or 6 have failed. Current limiting resistor R1 may be open.

C) Main power supply

Power supply bank D1-D4

A shorted diode will cause the primary current to go high and will trip the circuit breaker in the sub-panel. An open diode will cause the projected picture to have a pronounced flicker and may result in somewhat lower operating current.

Capacitors C1-C2-C3

A shorted capacitor or capacitors will raise the primary current and trip the circuit breaker in the sub-panel.

C1-C2-C3

If these are open or have lost capacity (ability to store energy) they will cause either a noticeable flicker in the projected picture or ignition problems or both. If in doubt, disconnect the capacitors one at a time. After disconnecting a capacitor, if no change in ignition or flicker is observed, then the capacitor is having no effect. Replace it.

Low capacity or an open capacitor affect ignition because there is insufficient surge current to reliably light the bulb. If disconnecting a capacitor does change either flicker or ignition, then the capacitor is functioning. Reconnect it. High ripple current caused by a diode failure will result in overheating of R3. You may use a clamp-on A.C. ammeter on the common D.C. line to the capacitor bank as an indirect method of checking ripple. The 8502 capacitor bank will have a nominal 25 ampere (AC) current flow. Higher current indicates a high ripple condition. Lower currents, may indicate open or deteriorated capacitors. Current into the capacitor bank varies with adjustment of the power output. As the output power is decreased, current flow of the capacitor bank will decrease.

Diode testing and replacement

To test a diode it must be disconnected from the circuit in which it is used. In many failure modes, the diode failure can be tentatively identified by discoloration of the bright surface because of excessive heat. You will still have to disconnect the diode and make further checks to verify failure. After disconnecting the diode, sue your VOM on the R x 1 scale. With the meter leads connected in one direction, the reading should be zero or close to it; reversing the meter leads, the indication should be a very high resistance. If the diodes does not exhibit these characteristics, replace it. If you have removed a diode from its heatsink or you are installing a new diode, observe the following instructions: Clean the area of the heaksink in which the diode is to be installed.

Warning

You must use heatsink compound. It is caustic in nature. Do not use for fingers; keep it away from your eyes; and do not ingest. Follow instructions on the container in which the compound is packaged.

You may obtain heatsink compound at your local electronics dealer. Apply the compound with a wood or plastic spatula; a popsicle stick will work well. A thin layer of compound is adequate. Use internal star washers as opposed to split washers. When tightening the diodes in the model 8502 power supply, the torque should be 90 in.lbs., 125 in.lbs. In replacing diodes, observe polarity. Model 8502 – diodes 1-3 are 1N3291R types, diodes 2-4 are 1N3291S types.



AS series

Introduction

These igniters are expressly designed to strike Xenon, Xenon-Mercury, Mercury, Metal Halide and similar arc lamps. They produce the high voltage, high frequency starting potential required to get the gas in the lamp to ionize and make the current flow possible.

The **AS** igniters meet the lamp manufacturers' recommendations to ensure immediate and correct ignition of the lamp when cold or in any cooling stage.

They should be installed close to the lamp (but thermally shielded from it); the high voltage lead must be as short as possible and carefully insulated to prevent corona loss and reduction of strike energy. The ambient temperature must not exceed 60°C.

Some models are equipped with a built-in special function relay allowing automatically cycled or timed ignition. Also this relay prevents the igniter from striking when the lamp is ON or if the no-load voltage to the lamp is not correct. As far as the insulation class, this device can be considered Cl. II (as per IEC 536), but it must be grounded for interference suppression.

Block diagram

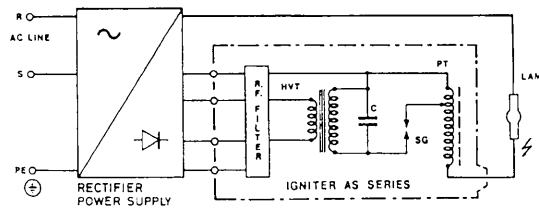

Outline drawing

AS-3040

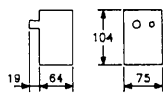

AS-8030

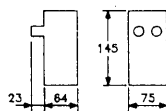

AS-16040/A

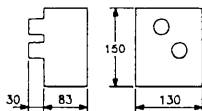

AS Series range

Models	AC input (50-60Hz)		H.V. output KV	Lamp current A	Weight Kg.
	Volt	A during ignition			
AS-3040	230V	0.8	40	30	1.3
AS-8030	$\pm 10\%$	1.5	30	80	1.5
AS-16040A		3.8	40	160	3.5

The suffix 'A', used for the model AS-16040A, means that it has a built-in relay system for automatic or short timed ignition.

4 - Unpacking and Installation Instructions

The following instructions should be read and fully understood prior to installing the equipment to ensure that the correct procedures are followed and all safety precautions are observed.

Note: If the equipment has been in storage for a considerable amount of time, it is advisable to conduct a routine maintenance check on all parts before installation.

Safety Precautions

This equipment should not be connected to an electrical supply before being installed. Installation procedures should be adhered to in order to ensure a safe working environment and reduce the risk of damage or personal injury.

Preparing the Mounting Position

Mark out and drill the fixing holes through the deck and bolt the searchlight base securely. On an uneven surface it is necessary to use a suitable sealant, such as silicone in order to ensure a weatherproofed joint. If anti-vibration mounts are to be fitted, the fixing holes for the mounts should also be marked out and drilled. Prior to manoeuvring the searchlight into its' fixing position, the AV mounts should be fitted to the base. When in the desired position, bolt the searchlight firmly down.

5 - Electrical Installation

For safety purposes, only competent personnel should perform the electrical installation. All equipment should be installed to current Electrical Regulations and Standards.

In order to obtain the maximum light output from the searchlight, it is essential that the full operating voltage of the lamp fitted be applied to the lampholder contacts.

Method of Electrical Connection

- 1) Disconnect the supply before working on the electrical system;
- 2) The searchlight must be connected to a fused electrical supply, using suitably sized cable;
- 3) If the searchlight is located a considerable distance from the mains supply, provision must be made in the cable size in order to overcome the voltage drop.

The PSU should NOT be positioned no more than 5 meters away from the Searchlight.

The following table below indicates the maximum length of cable to be used for the AC supply cable, from the control panel to the searchlight:

Searchlight	115v 2Kw	240v 2Kw
Cable Size (mm ²)	Distance Max	Distance Max
1.5	8 MTRS	37 MTRS
2.5	14 MTRS	60 MTRS
4	22 MTRS	96 MTRS
6	34 MTRS	150 MTRS
10	57 MTRS	250 MTRS

- 4) Whenever possible cable terminations should be made below deck and with approved terminal devices;
- 5) If a spare auxiliary fuse or circuit breaker is not available, one of the correct type and rating should be fitted and connected to a positive supply. It is advisable to locate a bus bar or main connection and avoid any direct connection to the supply;
- 6) For 110/220v AC products, the following colour coding system should be used for the customer supply cable:

Brown - Live
Blue - Negative
Green/Yellow - Earth

Note: This equipment must be earthed.

Installation Guidelines

A typical installation and connection routine for the searchlight with a Variable Speed Gearbox is as follows:

Referring to wiring diagram C22801, a supply is fed to the Control Panel, which then provides a common feed to the Motor Gearbox, Power Supply Unit and the Searchlight Control Panel.

The searchlight has been pre-wired with 3 meters of cable from the gearbox to junction box provided.

Cables required to be connected by the customer: -

4 core 6mm cable from the Junction Box to the PSU, doubling up the pairs,

3 core 2.5mm cable from the Junction Box to the Control Panel.

4 core 1.5mm cable from the Junction Box to the Control Panel.

12 core 0.5mm cable from the Junction Box to the Control Panel.

Optional Slave Panel Wiring

8 core 0.5mm² cable from the Slave Panel to the Junction Box.

The Mains cable to the Control Panel and 3 core 2.5mm cable from the PSU to the Control Panel (terminals 6 & 7) both to be supplied by the customer.

The searchlight head is pre-wired along with the connecting cable to the motor gearbox.

Basic Operation

When the searchlight is switched on a supply is fed to the PSU and linked to the ignitor. Also from the PSU, a dc output is fed to the lamp.

The ignitor ionises the gas within the lamp and this strikes the light.

All other facilities are fed via the control panels and motor gearbox.

Fitting instructions for the 2Kw xenon lamp

Referring to the diagram overleaf:

- 1) Unfasten the ten latches (A) on the front and rear of the searchlight;
- 2) Remove the front bezel (B) and rear bezel (C) assemblies;
- 3) Unscrew the two M6 hexagon screws (D) from the front lampholder mounting block (E) and remove the front lampholder assembly from the mounting bracket;
- 4) Loosen the knurled screw on the front (F) and rear (G) lampholder assemblies;
- 5) The lamp can now be inserted, make sure that the negative (cathode) end of the lamp is towards the rear of the searchlight;
- 6) Tighten the knurled screw (G) on the rear lampholder assembly to hold the lamp in position;
- 7) Fasten the front lampholder mounting block back in position, it will be necessary to pull the front socket against its spring to fit over the lamp. When in place tighten the front knurled screw (F);
- 8) Fasten the front and rear lampholder leads as wiring diagram, ensuring the connections are secure;
- 9) The front bezel and rear bezel can now be replaced.
- 10) Removal is the reverse of the above.

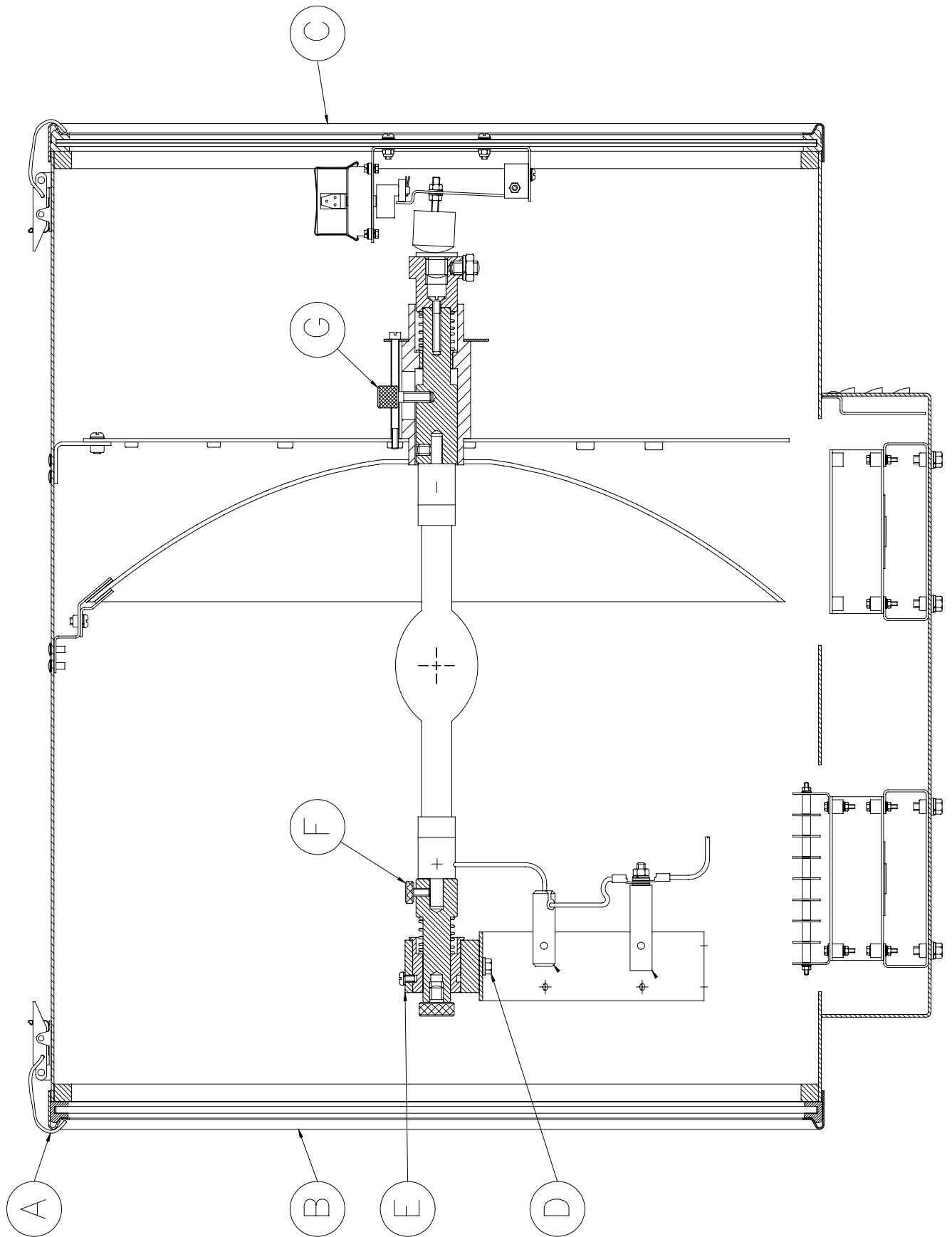

6 - Operating Instructions

This equipment is designed for use out of doors, in free air. Never place anything on, or cover, the searchlight when in use as this may present a hazard.

All PSU should be housed below deck/in doors. Never leave the PSU exposed to weather conditions.

The searchlight can be remotely positioned via the joystick control panel, with the facility for movement up, down, left and right. The speed of movement depends on the more pressure applied to the joystick the faster the searchlight moves. When in the desired position the joystick should be released so that it returns to its' home position, dead centre.

The variable speed gearbox has a fast and slow setting. You activate this by switching the controller switch on the control panel then selecting fast or slow.

The beam of the searchlight can be adjusted to give a variety of beam types. Using the yellow remote focus button on the joystick panel, the desired beam can be achieved for any particular application. The beam will move continuously through 'spot' to 'flood'. In order to fix the beam type, simply release the button at the desired position.

The heaters specified on this equipment are self-regulating and will shut off when they reach the dew point temperature.

This product should not be used for any purpose other than for which it was designed. Any modifications to the product should not be undertaken without consulting the manufacturer.

Setting to Work

Safe service in use necessitates the strict observance of the following precautions.

- Any article fabricated from quartz or glass is inherently fragile and care should therefore be taken, at all times, when handling lamps;
- Eye protection must be worn when handling lamps that have been removed from their packaging materials. The protective jacket should not be removed from the lamp for safety reasons, as there is a remote possibility of the lamp shattering violently, especially if it is subjected to mechanical shock or vibration;
- Ensure that the power rating of the Xenon lamp to be fitted is suitable for the lamphouse and power supply equipment (rectifier);
- Always isolate the equipment from the supply before inserting a lamp;
- Before inserting the lamp ensure that all contacts are clean. Contacts must be renewed at the slightest sign of corrosion. Sanding or filing down corroded areas is not recommended as this will only make the conducting surface between the pin and lampholder smaller, thus causing the lamp to overheat;
- The inert gas (Xenon) used in XBO lamps is under a pressure of several bar even when the bulb is cold. FOR SAFETY REASONS THE LAMP MAY ONLY BE INSERTED INTO THE LAMPHOUSE WITH THE PROTECTIVE JACKET FITTED;
- Do not twist or bend the fused quartz bulb when fitting the lamp as mechanical stresses MUST be avoided;
- Ensure that the spring contacts firmly surround the pins on the cap of the lamp. Do not apply unnecessary force when tightening the screws;
- After inserting the lamp, ensure that there is sufficient axial play in the lampholder. The lamp must be capable of unimpeded expansion when it warms up to operating temperature. Mechanical forces must not be applied to the fused quartz bulb;
- Electrical leads must be arranged in such a way that there is a sufficient air gap (approximately 40mm) between them and the lamphouse, in order to prevent flashovers from the ignition voltage. All flexible leads must have strain-relieving clamps;
- Before putting the lamp into service for the first time, check the polarity of the electrical connections. INCORRECT POLARITY WILL CAUSE IMMEDIATE DESTRUCTION OF THE LAMP;
- Before the protective jacket is removed, suitable protection must be worn i.e face mask and gloves with wrist protection;
- Never touch the quartz bulb with bare hands, as fingerprints will make the glass cloudy and cause a severe loss of light. This may also cause recrystallisation and thus weaken the bulb material. Should the bulb be inadvertently touched, remove fingerprints with methylated spirit and a clean, soft paper towel. The bulb should then be wiped with distilled water. NOTE: ALWAYS WEAR MASK AND GLOVES DURING CLEANING);
- All packaging and the protective jacket must be retained for re-use. Whenever removing a lamp, the protective jacket must always be used for safety reasons;

Notes:

- 1) XBO lamps are designed for dc operation only. The dc current may only be varied within the limits of the current control range. An XBO lamp operates best at rated current; over the life of the lamp, the current may be increased to its maximum value to compensate for loss of light. The output of the lamp can be reduced by operating the lamp at minimum current but this does not prolong the life of the lamp;
- 2) For safety reasons, XBO lamps should be replaced once they reach the end of their average lamp life, and not later than 1.25 times their average lamp life. After this time there is an increased risk of the lamp exploding;
- 3) The anode (positive cap marked '+') must be on top when the lamp is inserted in the vertical position. If the anode is incorrectly inserted the arc will be unstable, the bulb will blacken more quickly and the lamp will prematurely fail;
- 4) The HT lead from the high voltage terminal of the ignitor, must be connected to the cathode (negative cap marked '-'). If the lamp is connected with the wrong polarity it will be irreparably damaged after a very short time.
- 5) In all circumstances the lamp manufacturers data should be referred to when dealing with lamps.

7- Fault Finding

All fault finding must be conducted by a competent person or qualified Electrical Engineer.

Please refer to the following table for the trouble-shooting of Xenon lamps.

Fault	Cause	Remedy
<ul style="list-style-type: none"> ■ Wrong Polarity 	<ul style="list-style-type: none"> ■ Lamp incorrectly fitted ■ Faulty wiring 	<ul style="list-style-type: none"> ■ Anode (large electrode) must always be on top in vertical burning position ■ Check polarity, transpose connections if necessary
<ul style="list-style-type: none"> ■ Cap overheated ■ Cap temperature above 230°C 	<ul style="list-style-type: none"> ■ Faulty contacts ■ Cooling equipment defective 	<ul style="list-style-type: none"> ■ Check terminals, tighten or renew ■ Check cooling equipment and replace if necessary
<ul style="list-style-type: none"> ■ Arc unsteady 	<ul style="list-style-type: none"> ■ Lamp operated outside current control range ■ Magnetic stabilisation for horizontal operation defective 	<ul style="list-style-type: none"> ■ Correct current setting ■ Check magnetic stabilisation
<ul style="list-style-type: none"> ■ Bulb draws in air 	<ul style="list-style-type: none"> ■ Crack in graded seal caused by overheated cap ■ Maximum cap temperature 230°C 	<ul style="list-style-type: none"> ■ Check terminals - tighten or renew
<ul style="list-style-type: none"> ■ Glass erosion on fused quartz bulb 	<ul style="list-style-type: none"> ■ Lamp operated outside current control range ■ Lamp service life exceeded 	<ul style="list-style-type: none"> ■ Correct current setting ■ Check meter
<ul style="list-style-type: none"> ■ Electrodes damaged ■ Premature blackening 	<ul style="list-style-type: none"> ■ Current ripple too high ■ Auxiliary mirror incorrectly adjusted 	<ul style="list-style-type: none"> ■ Have power supply inspected ■ Adjust auxiliary mirror
<ul style="list-style-type: none"> ■ Asymmetrical blackening of lamp (in horizontal burning position) 	<ul style="list-style-type: none"> ■ Lamp operated too long in same position 	<ul style="list-style-type: none"> ■ Turn lamp through 180° after half service life

Failure of Lamp to Ignite

In the event of the xenon lamp failing to light the following steps should be taken:

- 1) Check that the mains supply is connected to the input of the PSU. On operating the switch, if the lamp does not light, switch off mains supply and check all fuses;
- 2) On pressing remote starting switch the lamp still does not ignite, check the searchlight head. On your command get an operator to activate the starting switch for approximately 10 seconds. During this time listen for any noise (cracking or hissing) coming from within the barrel. If this arcing is heard switch off the supply at the mains. Remove the rear bezel to expose the two supply leads to the xenon lamp. Using a dry cloth wipe these leads to remove any dust, moisture or condensation that may have formed around the inside of the barrel. Replace the rear bezel, ensuring the latches are securely fastened, and perform the check again, listening for the cracking. If the lamp still fails to ignite, switch off at the mains and replace the xenon lamp in accordance with the safety procedures within this manual and the manufacturers information.

Any further tests to be carried out with regards to lamp failure must be conducted by a competent electrical engineer and should not be carried out in an explosive atmosphere.

- 3) Before a xenon lamp will ignite, the electrically insulated gas between the electrodes must be ionised. This is done by the ignitor which produces a high frequency voltage (up to 30,000 volts or higher). The ignitor is activated by switching the lamp on and a crackling or hissing noise should be heard. The ignitor is housed within the rear of the searchlight barrel. This is a totally encapsulated unit and repair is not advised. If found to be faulty a new ignitor must be fitted.

Failure of Remote Focus Facility

The remote focus mechanism is controlled by a small electric motor situated at the rear of the searchlight barrel. If the focus of the light fails the following procedure should be adopted:

- 1) Remove the rear bezel from searchlight barrel and examine focus mechanism. If parts have become loose, tighten fasteners. The mechanism operates on a lever action and this should be checked for correct positioning;
- 2) If the mechanism is okay, check the supply to the motor. This can be done by simply placing a multi-meter across the motor terminals;
- 3) If supply is present, this indicates that the motor has failed. Replace the focus motor ensuring that the assembly is correct;
- 4) If no supply is present there is a fault in the junction box. This should be examined and rectified accordingly.

Note: If a fault occurs on the motor gearbox, the unit should be returned to Francis Searchlights Limited for fault evaluation and repair.

8 - Maintenance and Servicing

In order to prolong the service life and performance of your searchlight, the following maintenance guidelines are recommended:

- Maintenance checks should be conducted before every voyage or at least every three months;
- Before checking, disconnect the equipment from the supply;
- Visually inspect the condition of the equipment;
- Any major or minor structural damage should be rectified immediately in order to reduce sympathetic wear;
- After inspection it may be necessary to clean the inside of the searchlight. The following procedure should be adhered to:
 - Remove the front bezel;
 - Clean the front glass inside and out using a proprietary glass cleaner or metal polish;
 - Clean the reflector if required;
 - Check the reflector mounting gaskets. If signs of corrosion or damage are evident, replace as necessary;
 - Ensure that the lampholder is free from corrosion or other damage;
 - Check earthing point for conductivity;
- It is advisable to check all seals and gaskets for signs of degradation. Renew if necessary;
- Upon completing all maintenance requirements the searchlight should be tested for full working order (approximately 20 minutes).

If in any doubt as to the correct servicing procedures to adopt please contact your distributor/agent or the manufacturer who will be able to advise the best course of action for your product.

9 – General Assembly & Wiring Diagrams

Drawing Number	Description
A2471/A2473	FX560RC 2Kw variable speed G.A.
C22801	240v 2Kw Xenon RC Wiring Diagram variable speed
C24511	115v 2Kw Xenon RC Wiring Diagram Variable Speed Control Panel Outline Drawing variable speed PSU Schematic PSU Control Wiring
C23591	Junction Box Assembly

DO NOT SCALE DRAWING (732) THIRD ANGLE PROJECTION (738)

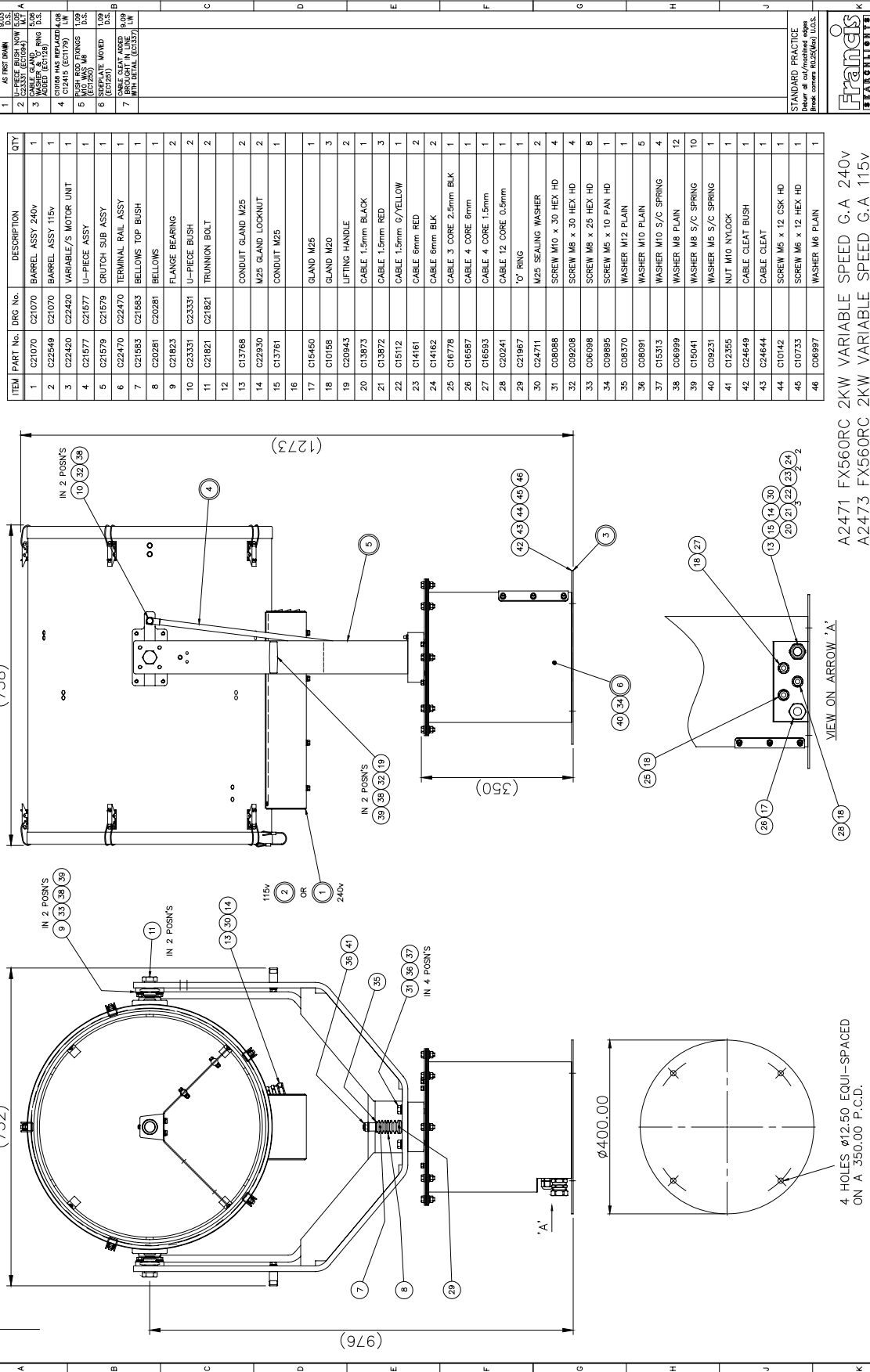

ITEM	PART No.	DRG No.	DESCRIPTION	QTY
1	C21070	C21070	BARREL ASSY 240v	1
2	C22549	C21070	BARREL ASSY 115v	1
3	C22420	C22420	VARIABLE/S MOTOR UNIT	1
4	C21577	C21577	U-PIECE ASSY	1
5	C21579	C21579	CRUTCH SUB ASSY	1
6	C22470	C22470	TERMINAL RAIL ASSY	1
7	C21583	C21583	BELLOWS TOP BUSH	1
8	C20281	C20281	BELLOWS	1
9	C21823	C21823	FLANGE BEARING	2
10	C23331	C23331	U-PIECE BUSH	2
11	C21821	C21821	TRUNNION BOLT	2
12				
13	C13768		CONDUIT GLAND M25	2
14	C22930		M25 GLAND LOCKNUT	2
15	C13761		CONDUIT M25	1
16				
17	C1E450		GLAND M25	1
18	C10158		GLAND M20	3
19	C20943		LIFTING HANDLE	2
20	C13873		CABLE 1.5mm BLACK	1
21	C13872		CABLE 1.5mm RED	3
22	C15112		CABLE 1.5mm G/YELLOW	1
23	C14161		CABLE 6mm RED	2
24	C14162		CABLE 6mm BLK	2
25	C16778		CABLE 3 CORE 2.5mm BLK	1
26	C16587		CABLE 4 CORE 6mm	1
27	C16583		CABLE 4 CORE 1.5mm	1
28	C20241		CABLE 12 CORE 0.5mm	1
29	C21967		'O' RING	1
30	C24711		M25 SEALING WASHER	2
31	C08088		SCREW M10 x 30 HEX HD	4
32	C09208		SCREW M8 x 30 HEX HD	4
33	C06098		SCREW M8 x 25 HEX HD	8
34	C09895		SCREW M5 x 10 PAN HD	1
35	C08370		WASHER M12 PLAIN	1
36	C06091		WASHER M10 PLAIN	5
37	C15313		WASHER M10 S/C SPRING	4
38	C06999		WASHER M8 PLAIN	12
39	C15041		WASHER M8 S/C SPRING	10
40	C09231		WASHER M5 S/C SPRING	1
41	C12355		NUT M10 NYLOCK	1
42	C24649		CABLE CLEAT BUSH	1
43	C24644		CABLE CLEAT	1
44	C10142		SCREW M5 x 12 CSK HD	1
45	C10733		SCREW M6 x 12 HEX HD	1
46	C06997		WASHER M6 PLAIN	1

STANDARD PRACTICE
FRANCIS SEARCHLIGHTS LIMITED
(Break down to 0.25(Mm) U.S.)

A2471 FX560RC 2KW VARIABLE SPEED G.A 240V
A2473 FX560RC 2KW VARIABLE SPEED G.A 115V

DATE	BY	DESCRIPTION
10/03/03	AS FIRST DRAWN	
10/03/03	C23331 (EC1094)	
10/03/03	C21070 (EC1094)	
10/03/03	WASHER M10 (EC1126)	
10/03/03	WASHER M8 (EC1126)	
10/03/03	CONSOLE HAS REPLACED FOR	
10/03/03	WASHER M8 (EC1126)	
10/03/03	WASHER M5 (EC1126)	
10/03/03	M10 WASER (EC1126)	
10/03/03	M10 WASER (EC1126)	
10/03/03	SEPARATE MOVED	
10/03/03	CABLE CLEAN ARMED	
10/03/03	WITH METAL (EC1357)	

FRANCIS SEARCHLIGHTS LIMITED
UNION ROAD . BOLTON . BL2 2HU

FRANCIS SEARCHLIGHTS LIMITED . UNION ROAD . BOLTON . BL2 2HU
FX560RC 2KW VARIABLE SPEED G.A

FINISH MATERIAL DESCRIPTION

DRWING U.S. DATE 10/03/03 TOLERANCES
DIMENSIONS IN MILLIMETRES
Screw Callings to ISO 8000 CTR
Screw Callings to ISO 8000 CTR
Hole centres & points ±
Angles ±

FRANCIS SEARCHLIGHTS LIMITED . UNION ROAD . BOLTON . BL2 2HU
FX560RC 2KW VARIABLE SPEED G.A

FRANCIS SEARCHLIGHTS LIMITED . UNION ROAD . BOLTON . BL2 2HU
FX560RC 2KW VARIABLE SPEED G.A

FRANCIS SEARCHLIGHTS LIMITED . UNION ROAD . BOLTON . BL2 2HU
FX560RC 2KW VARIABLE SPEED G.A

FRANCIS SEARCHLIGHTS LIMITED . UNION ROAD . BOLTON . BL2 2HU
FX560RC 2KW VARIABLE SPEED G.A

FRANCIS SEARCHLIGHTS LIMITED . UNION ROAD . BOLTON . BL2 2HU
FX560RC 2KW VARIABLE SPEED G.A

FRANCIS SEARCHLIGHTS LIMITED . UNION ROAD . BOLTON . BL2 2HU
FX560RC 2KW VARIABLE SPEED G.A

FRANCIS SEARCHLIGHTS LIMITED . UNION ROAD . BOLTON . BL2 2HU
FX560RC 2KW VARIABLE SPEED G.A

FRANCIS SEARCHLIGHTS LIMITED . UNION ROAD . BOLTON . BL2 2HU
FX560RC 2KW VARIABLE SPEED G.A

FRANCIS SEARCHLIGHTS LIMITED . UNION ROAD . BOLTON . BL2 2HU
FX560RC 2KW VARIABLE SPEED G.A

FRANCIS SEARCHLIGHTS LIMITED . UNION ROAD . BOLTON . BL2 2HU
FX560RC 2KW VARIABLE SPEED G.A

FRANCIS SEARCHLIGHTS LIMITED . UNION ROAD . BOLTON . BL2 2HU
FX560RC 2KW VARIABLE SPEED G.A

FRANCIS SEARCHLIGHTS LIMITED . UNION ROAD . BOLTON . BL2 2HU
FX560RC 2KW VARIABLE SPEED G.A

FRANCIS SEARCHLIGHTS LIMITED . UNION ROAD . BOLTON . BL2 2HU
FX560RC 2KW VARIABLE SPEED G.A

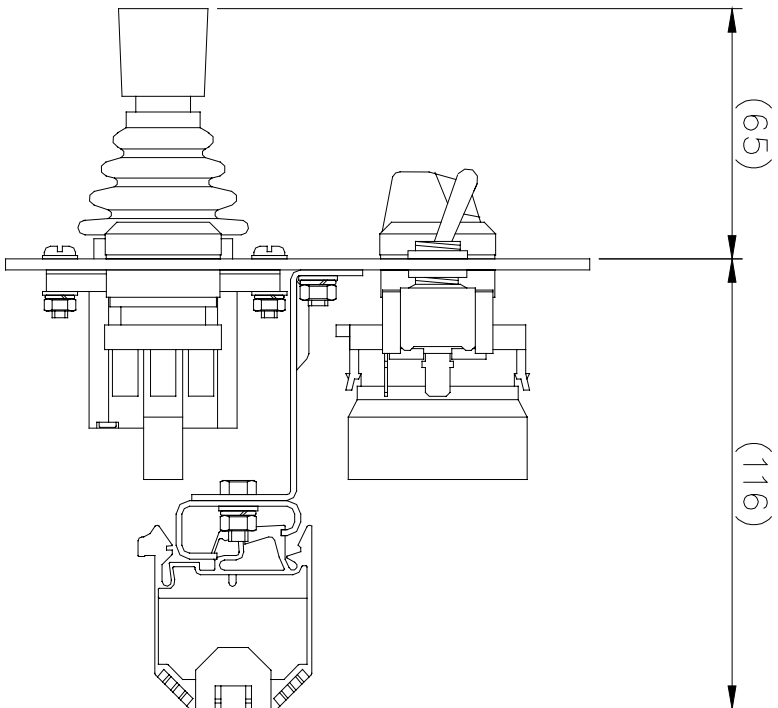
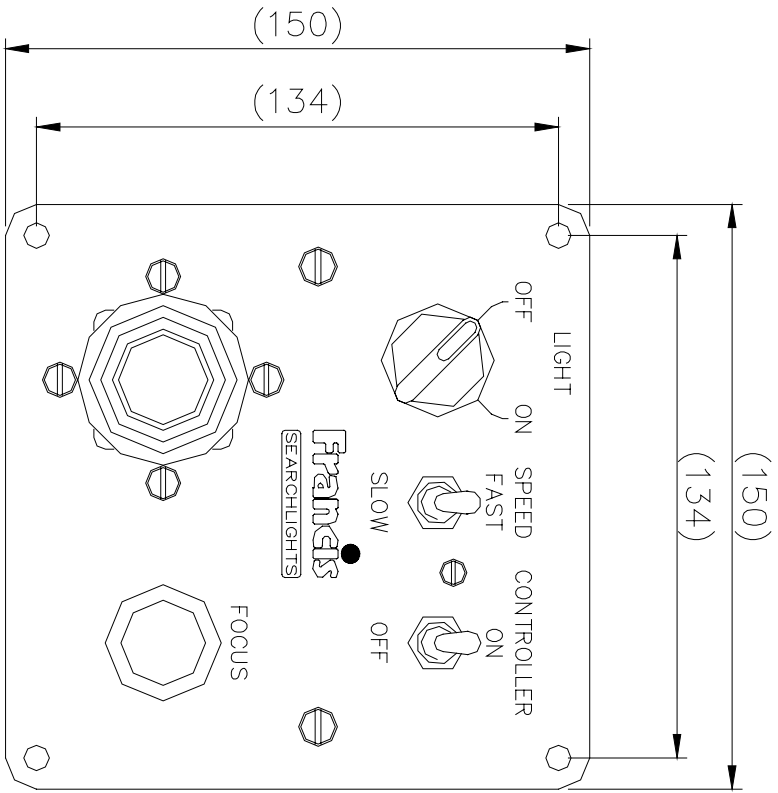

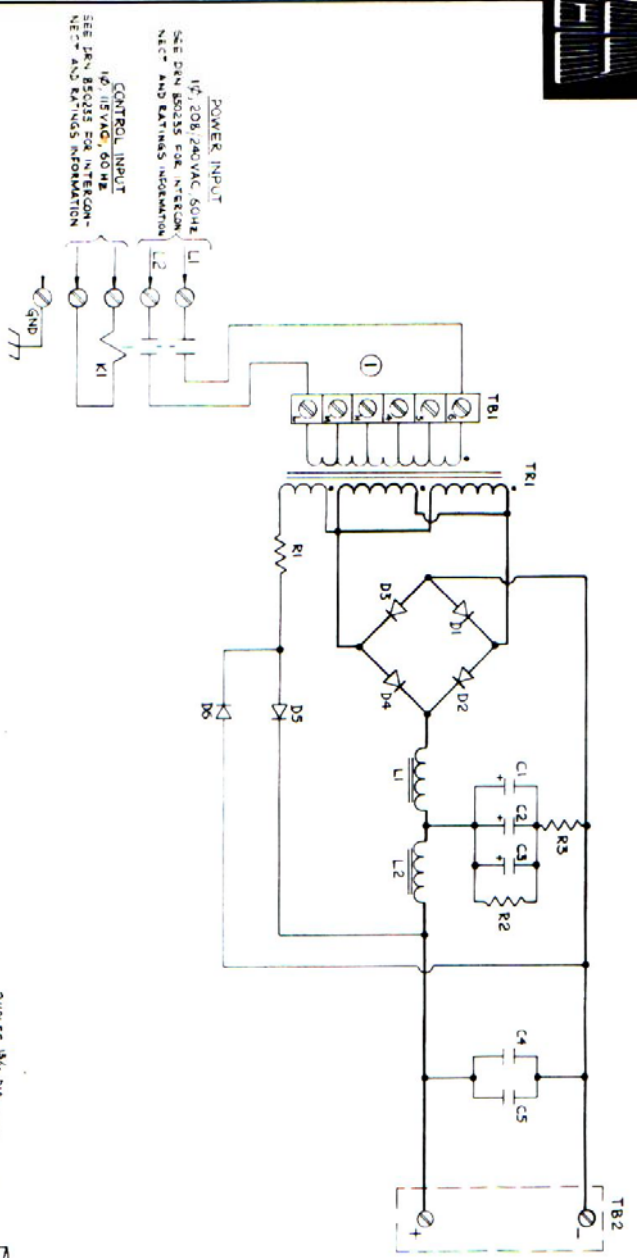
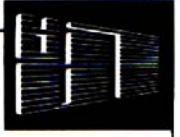

DC OUTPUT
 22-30 VOLTS
 50-85 AMP'S
 400-2000 WATTS
 (SEE DRN 850235
 FOR INTERCONNECT
 AND RATING INFORMATION)

SYMBOL	DESCRIPTION	L.P.A. PN	QTY
C-3	CAPACITOR, 4000 mfd, 150V	C101	3
C-4	CAPACITOR, 0.05 mfd, 1KV	C102	1
C-5	CAPACITOR, 68 mfd, 400VDC	C103	1
D1-3	DIODE IN2291E, 100 AMP, 400V	D111	2
D1-4	DIODE IN2291S, 100 AMP, 400V	D112	2
D1-5	DIODE, N4004	D100	2
K1	CONTACTOR, 2 POLE	KY103	1
L1-2	CHOKE	CH4502	2
R1	RESISTOR, WIREWOUND, 850, 100 W	R100	1
R2	RESISTOR, WIREWOUND, 3500, 10W	R101	1
R3	RESISTOR, METAL STRIP, 06.2, 20W	R102	1
TE1	TRANSFORMER	TR8502A	1
TB1	TERMINAL BLOCK, CURTIS-H6, INPUT	TB101	1
TB2	TERMINAL BLOCK, OUTPUT	850115	1

NOTES:
 (1) OUTPUT CURRENT IS ADJUSTED BY CHANGING POSITION OF WIRES ON TB1. LETTERS H-L FOR SMALL INCREMENTS (H=HIGHEST, L=LOWEST) NUMBERS 4-6 FOR LARGE INCREMENTS (4=HIGHEST, 6=LOWEST) FOR 240VAC INPUT USE ONLY '0' OR '5'. FOR 208 VAC INPUT USE ANY (NORMALLY '4' OR '5')

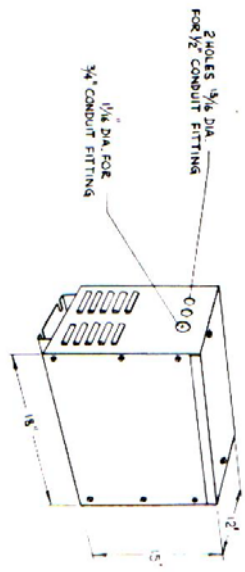

L. P. ASSOCIATES, INC		REVISION
MODEL	FIG. 6	ISSUED BY: E.S.
DATE	6-14-85	
SCHEMATIC & PARTS LIST		
CODE IDENT	L.P.A. MODEL NO 8502	DRAWING NUMBER
17665		850201E

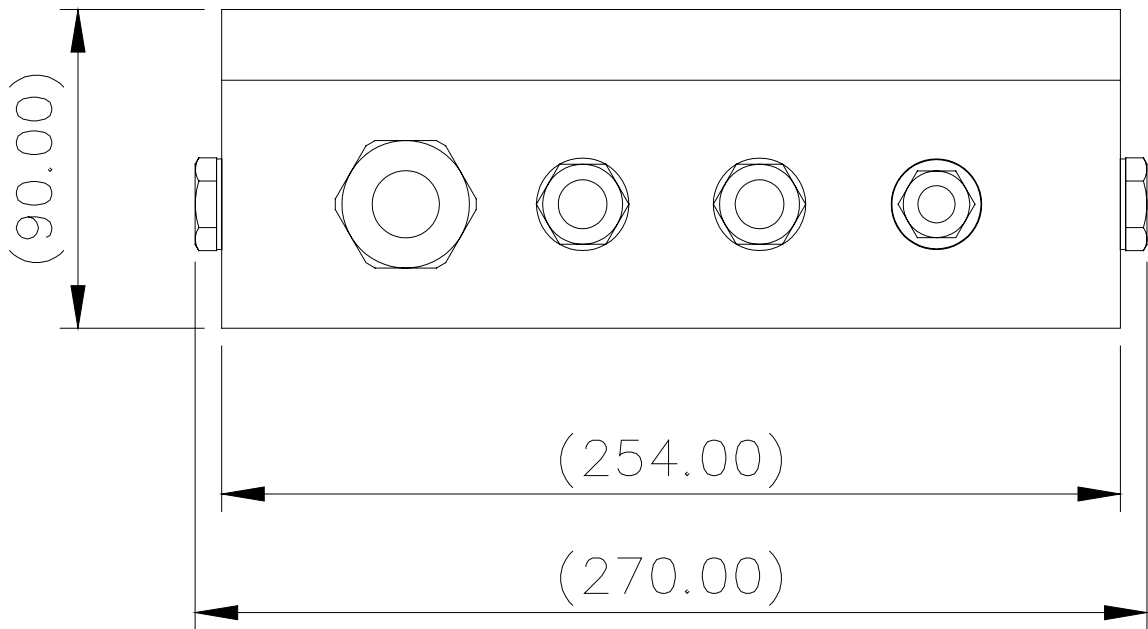
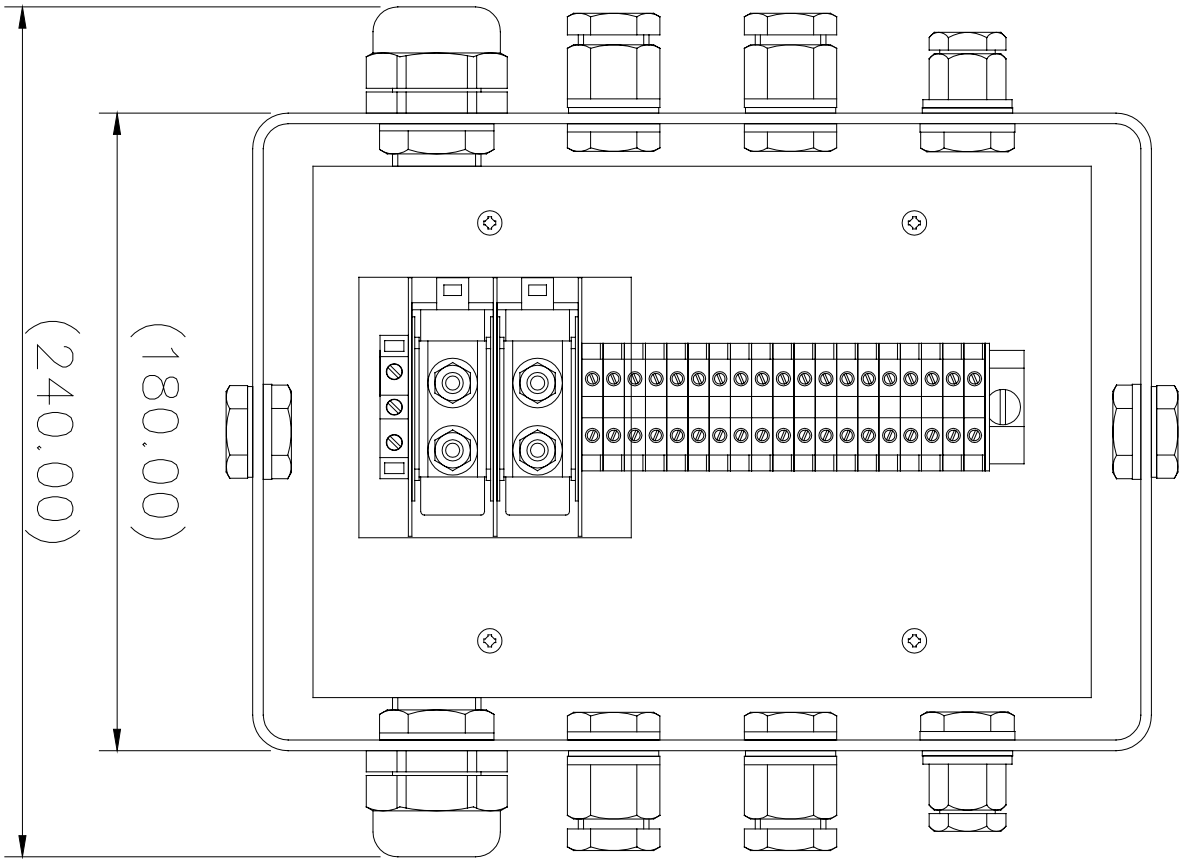

Back To Top

10 - Spare Parts List

The following spare parts can be ordered directly from the manufacturer:

Part Number	Description
C15392-00	Power Supply Unit (240v)
C23860-00	Step Up Transformer
C12081-00	Ignitor (240v)
C12080-00	Ignitor (115v)
C20224-00	Fan (240v)
C21573-00	Fan (115v)
D20195	2Kw Xenon Lamp
C23002-00	Switch 20A - On/Off
C14142-00	Switch – Focus
C22347-00	Joystick
C22941-00	Switch (Controller/speed)
C20881-00	Front Glass
C20569-00	Front/Rear Bezel Gasket
C15458-00	Motor - Remote Focus
C15459-00	Bearing
C23277-01	Heater & Fuse Assembly
C06779-00	Reflector
C20281-00	Bellows

Motor Gearbox Spares

C22403-01	Pan Motor S/Assy
C22287-00	Tilt Motor
C22380-00	Microswitch no lever
C22382-00	Microswitch with lever
C24030-01	'I' Drive Pan Speed Controller
C24060-01	'I' Drive Tilt Speed Controller
C23530-00	P.S.U.
C22381-00	Pedestal Top Sealing Gasket
C21225-00	Pedestal Cover Gasket

In order to prolong the life and performance of your product, we recommend that you only specify Francis Searchlights spare parts. This will ensure that any warranties on your equipment will not be invalidated.

When ordering spare parts please contact the Sales Department at Francis Searchlights Limited. Please quote searchlight model and serial number at all times. This will enable a fast response to your spares' requirements.

[Back To Top](#)