



User Instruction & Installation Manual

LX300 Remote Control 300 watt Xenon Searchlight



Product Reference Number:

A2623 – LX300RC 300w 240v

A6057 – LX300RC 300w 115v

Manufacturers details:

Francis Searchlights Ltd
Union Road, Bolton
Lancashire, BL2 2HJ, UK
Tel: +44 (0) 1204 558960
Fax: +44 (0) 1204 558979
<http://www.francis.co.uk>
E-mail: sales@francis.co.uk

Distributor details:



Manual Part Number: C23681

Issue : 1

CONTENTS

- 1 - Introduction
- 2 - Safety Precautions
- 3 - Technical Information
- 4 - Unpacking and Installation Instructions
- 5 - Electrical Installation
- 6 - Operating Instructions
- 7 - Fault Finding
- 8 - Maintenance and Servicing
- 9 - Wiring Diagram & General Assembly Drawing
- 10 - Spare Parts List

1 - Introduction

It is imperative that this manual is read carefully and understood before installing your equipment. For your future reference please keep this manual in a safe place.

Thank you for specifying a product from the Francis Searchlights range. All Francis products are designed to give complete customer satisfaction and are manufactured to the highest engineering standards in order to ensure optimum performance and service life.

The Francis Xenon range combines features proven over many years service in the most hazardous conditions in both marine and land installations.

In order to prolong the life and performance of your product, we recommend that you only specify Francis Searchlights spare parts. This will also ensure that any warranties on your equipment will not be invalidated. Information on spares ordering and parts is provided in this manual.

Should you ever need to contact Francis Searchlights Ltd. regarding your equipment, please quote the Product Serial Number at all times.

2 - Safety Precautions

The following instructions must be adhered to, in order to ensure a safe working environment and the safety of the user.

Note: When unpacking or manoeuvring the searchlight into its fixing position, suitable lifting points must be used in order to prevent damage to the equipment or personal injury.

- Because of the high internal pressure within the lamp, there is a risk of explosion in either a hot or cold state;
- During operation this lamp emits intense UV radiation which is harmful to the eyes and skin. Suitable protection should be worn;
- The high luminance of the arc can cause severe damage to the eye if viewed directly. ALWAYS wear suitable protective goggles when viewing the lamp;
- Always use protective sleeves supplied with the lamp;
- Should it be necessary to examine the lamp with the front bezel removed, always use a protective shield and wear goggles to ensure a safe working environment;
- Searchlights get hot. Never touch the unit when lit and always allow 15 to 20 minutes for cooling down after turning the searchlight off;
- Never place anything on or cover the searchlight when in use;
- Ensure the lamp has cooled sufficiently before removal;
- If undue force appears necessary to remove the lamp, the equipment should be inspected by a competent person or contact the manufacturer;
- When disposing of lamps, return the lamp, via the supplier, to the lamp manufacturer in its complete packaging;
- Due to the vast range of lamps available it may appear possible that more powerful lamps can be used in the equipment than for which it was designed. Even when the unit will physically accept a higher wattage or voltage lamp, this substitution is not recommended and is dangerous. This action will also void any warranties on the equipment.
- Always refer to the lamp manufacturers technical data when dealing with lamps.

3 – Technical Information

This product has been designed to operate in accordance with the product specification. The LX300RC 300watt searchlight has the following features:

- Constructed from stainless steel;
- Parabolic aluminium deep-dish reflector;
- Stove enamel painted;
- 365° horizontal rotation;
- Vertical movement +30° to -30°;
- Motor speed 20°/sec (Pan), 5°/sec (Tilt);
- Remote focus facility;
- Internal self-regulating heater;
- Economical 600 hour lamp life;
- Toughened front glass;
- Supplied with control panel incorporating control joystick, focus control and on/off switch;
- Luminous flux 7600;
- Colour temperature 6000K;
- Optional pedestal available upon request;
- Sealing to IP66 PSU & Searchlight;

The searchlight also performs to the following optical data:

- Xenon light source
- Lamp Wattage - 300 Watts;
- Supply voltage – 110v/240v AC 1Ph 50/60 Hz;
- Peak Beam Candlepower – 12.1 million lux;
- Range – 3487 metres;
- Adjustable lamp focus, 1° spot to 10° flood;
- Temperature range: -50°C

In order that the searchlight operates correctly it is imperative that competent personnel are responsible for the installation, operation and servicing of this equipment. Failure to adhere to this advice may cause premature failure or incorrect operation of the searchlight, which may damage the equipment or cause personal injury.

4 - Unpacking and Installation Instructions

The following instructions should be read and fully understood prior to installing the equipment to ensure that the correct procedures are followed and all safety precautions are observed.

Note: If the equipment has been in storage for a considerable amount of time, it is advisable to conduct a routine maintenance check on all parts before installation.

Safety Precautions

This equipment should not be connected to an electrical supply before being installed. Installation procedures should be adhered to in order to ensure a safe working environment and reduce the risk of damage or personal injury.

Preparing the Mounting Position

Mark out and drill the fixing holes through the deck. If anti-vibration mounts are to be fitted, the fixing holes for the mounts should also be marked out and drilled. Prior to manoeuvring the searchlight into its' fixing position, the AV mounts should be fitted to the base. When in the desired position, bolt the searchlight firmly down.

5 - Electrical Installation

For safety purposes, only competent personnel should perform the electrical installation. All equipment should be installed to current Electrical Regulations and Standards.

In order to obtain the maximum light output from the searchlight, it is essential that the full operating voltage of the lamp fitted be applied to the lampholder contacts.

Method of Electrical Connection

- 1) Disconnect the supply before working on the electrical system;
- 2) The searchlight must be connected to a fused electrical supply, using suitably sized cable;
- 3) If the searchlight is located a considerable distance from the supply, provision must be made in the cable size in order to overcome the voltage drop.

The following table below indicates the maximum length of cable to be used for the supply cable, from the control panel to the searchlight:

Searchlight	115v 300w	240v 300w
Cable Size (mm ²)	Distance Max	Distance Max
1.5	57 MTRS	247 MTRS
2.5	93 MTRS	404 MTRS
4.0	147 MTRS	640 MTRS
6.0	229 MTRS	997 MTRS
10.0	384 MTRS	1869 MTRS

- 4) Whenever possible cable terminations should be made below deck and with approved terminal devices;
- 5) If a spare auxiliary fuse or circuit breaker is not available, one of the correct type and rating should be fitted and connected to a positive supply. It is advisable to locate a bus bar or main connection and avoid any direct connection to the supply:

Installation Guidelines

A typical installation and connection routine for the searchlight is as follows:

Referring to the wiring diagram C23680, a 115v/240v supply is fed to the joystick panel which then provides a common feed to the pan and tilt motor gearbox, Power Supply Unit (PSU) and the searchlight head.

The searchlight head, PSU, joystick control panel and pan and tilt motor gearbox are supplied pre-wired internally.

Cables pre-fitted:-

12 core 0.5mm from the Motor Gearbox to the Junction Box (3 metres).
4 core 1.5mm from the Motor Gearbox to the Junction Box (3 metres).
4 core 2.5mm from the Motor Gearbox to the Junction Box (3 metres).
9 single cores from the Motor Gearbox to the Searchlight.

Cables requiring connection by customer :-

12 core 0.5mm from the Junction box to the Joystick Control Panel.
4 core 1.5mm from the Junction Box to the Joystick Control Panel.
4 core 1.5mm from the Joystick Control Panel to the PSU.
4 core 2.5mm from the PSU to the Junction Box.

When the light is in operation the output from the PSU should be 20v at 15 amps.

Basic Operation

When the searchlight is turned on a 115v/240v supply is fed to the PSU. This in turn generates a sufficient voltage to the ignitor in order that the ignition voltage is achieved and the Xenon lamp strikes.

After the lamp has lit, the PSU regulates the voltage through the ignitor so that the lamp operates within its design parameters.

6 - Operating Instructions

This equipment is designed for use out of doors, in free air. Never place anything on, or cover, the searchlight when in use as this may present a hazard.

The searchlight can be remotely positioned via the joystick control panel, with the facility for movement up, down, left and right. When in the desired position the joystick should be released so that it returns to its' home position, dead centre.

The beam of the searchlight can be adjusted to give a variety of beam types. Using the yellow remote focus button on the joystick panel, the desired beam can be achieved for any particular application. The beam will move continuously through 'spot' to 'flood'. In order to fix the beam type; simply release the button at the desired position.

The heater specified on this equipment is self-regulating and will shut off when the dew point temperature is reached.

This product should not be used for any purpose other than for which it was designed. Any modifications to the product should not be undertaken without consulting the manufacturer.

Setting to Work

Safe service in use necessitates the strict observance of the following precautions.

- Any article fabricated from quartz or glass is inherently fragile and care should therefore be taken, at all times, when handling lamps;
- Eye protection must be worn when handling lamps that have been removed from their packaging materials;
- Ensure that the power rating of the lamp to be fitted is suitable for the lamphouse and power supply equipment;
- Always isolate the equipment from the supply before inserting a lamp;
- Before inserting the lamp ensure that all contacts are clean. Contacts must be renewed at the slightest sign of corrosion. Sanding or filing down corroded areas is not recommended as this will only make the conducting surface between the pin and lampholder smaller, thus causing the lamp to overheat;
- Do not twist or bend the fused quartz bulb when fitting the lamp as mechanical stresses **MUST** be avoided;
- When inserting or removing a lamp, always hold it securely by its' base in order to prevent breakage between base and bulb;
- The lampholder must not exercise mechanical tensions on the lamp, neither during insertion or operation. Contacts must not discolour during use;
- For safety reasons, the lamp should be replaced once it has reached its' average life, and not later than 1.25 times the stated life. With continuing use the risk of the lamp exploding increases due to alterations within the quartz;
- When fitting the lamp suitable protection must be worn i.e face mask and gloves with wrist protection;
- Never touch the quartz bulb with bare hands, as fingerprints will make the glass cloudy and cause a severe loss of light. This may also cause recrystallisation and thus weaken the bulb material. Should the bulb be inadvertently touched, remove fingerprints with methylated spirit and a clean, soft paper towel. The bulb should then be wiped with distilled water. **NOTE: ALWAYS WEAR MASK AND GLOVES DURING CLEANING);**

In all circumstances the lamp manufacturers data should be referred to when dealing with lamps.

7- Fault Finding

All fault finding must be conducted by a competent person or qualified Electrical Engineer.

Please refer to the following table for the trouble-shooting of Xenon lamps.

Fault	Cause	Remedy
<ul style="list-style-type: none"> ■ Wrong Polarity 	<ul style="list-style-type: none"> ■ Lamp incorrectly fitted ■ Faulty wiring 	<ul style="list-style-type: none"> ■ Anode (large electrode) must always be on top in vertical burning position ■ Check polarity, transpose connections if necessary
<ul style="list-style-type: none"> ■ Cap overheated ■ Cap temperature above 230°C 	<ul style="list-style-type: none"> ■ Faulty contacts ■ Cooling equipment defective 	<ul style="list-style-type: none"> ■ Check terminals, tighten or renew ■ Check cooling equipment and replace if necessary
<ul style="list-style-type: none"> ■ Arc unsteady 	<ul style="list-style-type: none"> ■ Lamp operated outside current control range ■ Magnetic stabilisation for horizontal operation defective 	<ul style="list-style-type: none"> ■ Correct current setting ■ Check magnetic stabilisation
<ul style="list-style-type: none"> ■ Bulb draws in air 	<ul style="list-style-type: none"> ■ Crack in graded seal caused by overheated cap ■ Maximum cap temperature 230°C 	<ul style="list-style-type: none"> ■ Check terminals - tighten or renew
<ul style="list-style-type: none"> ■ Glass erosion on fused quartz bulb 	<ul style="list-style-type: none"> ■ Lamp operated outside current control range ■ Lamp service life exceeded 	<ul style="list-style-type: none"> ■ Correct current setting ■ Check meter
<ul style="list-style-type: none"> ■ Electrodes damaged ■ Premature blackening 	<ul style="list-style-type: none"> ■ Current ripple too high ■ Auxiliary mirror incorrectly adjusted 	<ul style="list-style-type: none"> ■ Have power supply inspected ■ Adjust auxiliary mirror
<ul style="list-style-type: none"> ■ Asymmetrical blackening of lamp (in horizontal burning position) 	<ul style="list-style-type: none"> ■ Lamp operated too long in same position 	<ul style="list-style-type: none"> ■ Turn lamp through 180° after half service life

Failure of Lamp to ignite

In the event of the lamp failing to light the following steps should be taken:

- 1) Check that the supply is connected to the input of the PSU and check all connections as per the wiring diagram. On operation if the lamp does not light, switch off supply and check all fuses;
- 2) Check the PSU enclosure. On your command get an operator to switch on the light for approximately 2 seconds. During this time listen for any noise (cracking or hissing) coming from within. If this arcing is heard switch off the supply. Remove the front and rear bezels to expose the two supply leads from the PSU enclosure to the lamp. Using a dry cloth wipe these leads to remove any dust, moisture or condensation that may have formed around the inside of the barrel. Replace the front and rear bezels, ensuring the latches are securely fastened, and perform the check again, listening for the cracking. If the lamp still fails to ignite, switch off at the supply and replace the lamp in accordance with the safety procedures within the manual and the manufacturers information.

Any further tests to be carried out with regards to lamp failure must be conducted by a competent electrical engineer and should not be carried out in an explosive atmosphere.

- 3) Before a xenon lamp will ignite, the electrically insulated gas between the electrodes must be ionised. This is done by the ignitor which produces a high frequency voltage (up to 25,000 volts or higher). Switching the lamp on activates the ignitor. A cracking or hissing noise should be heard. The ignitor is housed within the rear of the searchlight. If found to be faulty return to Francis Searchlights Ltd for evaluation and repair.

Failure of Remote Focus Facility

The remote focus mechanism is controlled by a small electric motor situated on the rear bulkhead assembly within the searchlight barrel. If the focus of the light fails the following procedure should be adopted:

- 1) Remove the rear bezel from the searchlight barrel and examine focus mechanism. If parts have become loose, tighten fasteners. The mechanism operates on a cam action and this should be checked for correct positioning;
- 2) If the mechanism is okay, check the supply to the motor. This can be done by simply placing a multimeter across the motor terminals;
- 3) If supply is present, this indicates that the motor has failed. Replace the focus motor ensuring that the assembly is correct;
- 4) If no supply is present trace all wiring back.

Note: If a fault occurs on the pan and tilt gearbox, the unit should be returned to Francis Searchlights Limited for fault evaluation and repair.

8 - Maintenance and Servicing

In order to prolong the service life and performance of your searchlight, the following maintenance guidelines are recommended:

- Maintenance checks should be conducted before every voyage or at least every three months;
- Before checking, disconnect the equipment from the supply;
- Visually inspect the condition of the equipment;
- Any major or minor structural damage should be rectified immediately in order to reduce sympathetic wear;
- After inspection it may be necessary to clean the inside of the searchlight. The following procedure should be adhered to:
 - Remove the front bezel;
 - Clean the front glass inside and out using a proprietary glass cleaner or metal polish;
 - Clean the reflector if required;
 - Ensure that the lampholder is free from corrosion or other damage;
- It is advisable to check all seals and gaskets for signs of degradation. Renew if necessary;
- Upon completing all maintenance requirements the searchlight should be tested for full working order (approximately 20 minutes).

If in any doubt as to the correct servicing procedures to adopt please contact your distributor/agent or the manufacturer who will be able to advise the best course of action for your product.

Notes for Lamp Fitting/Removal for LX300RC 300w Xenon

To fit lamp:

- Remove lamp from packaging;
- Remove front and rear bezels from searchlight by unfastening the latches;
- Place the lamp through the lampholder HT/reflector boss and secure with T-bar at rear;
- Place the rear black lead onto the T-bar and secure in place using screw.
- Place the HT lead (large white lead) over the front of the lamp (positive) and secure in position using the lamp heatsink;
- Now screw the Tufnol insulator into the lamp heatsink and ensure that the HT lead is tightly secured to prevent any arcing;
- Place the PTFE bush over the insulator and fix mechanism in position by pushing the retaining clip through the insulator;
- Replace front and rear bezel assemblies and fasten down clips securely, ensuring bezels are central to barrel and a good seal is achieved;
- Reverse this procedure for lamp removal.

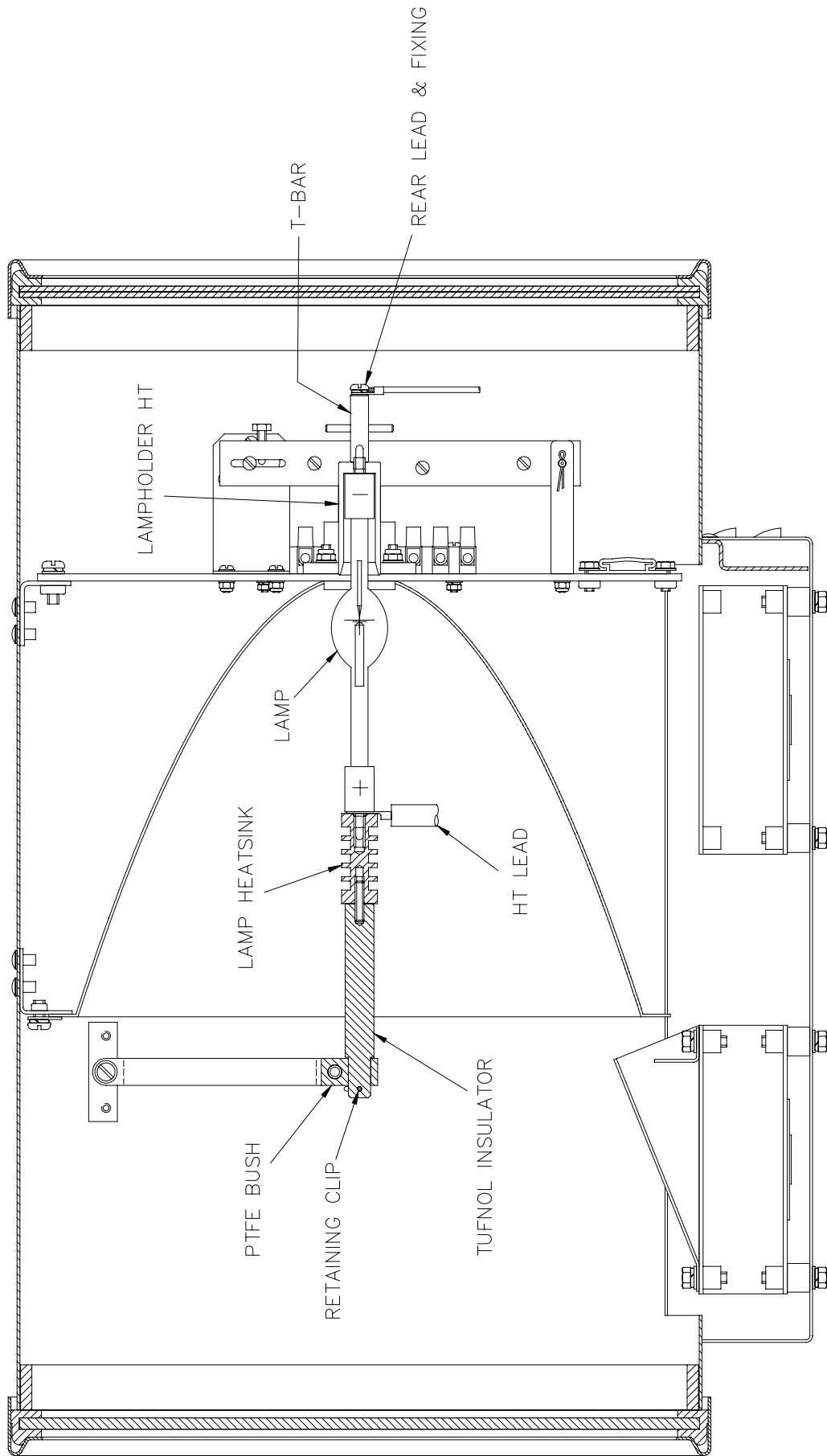

9 - Wiring Diagram & General Assembly Drawing

Drawing Number	Description
A2623/A6057	LX300RC 300w Xenon G.A.
C23680	Wiring Diagram
C24460	Junction Box

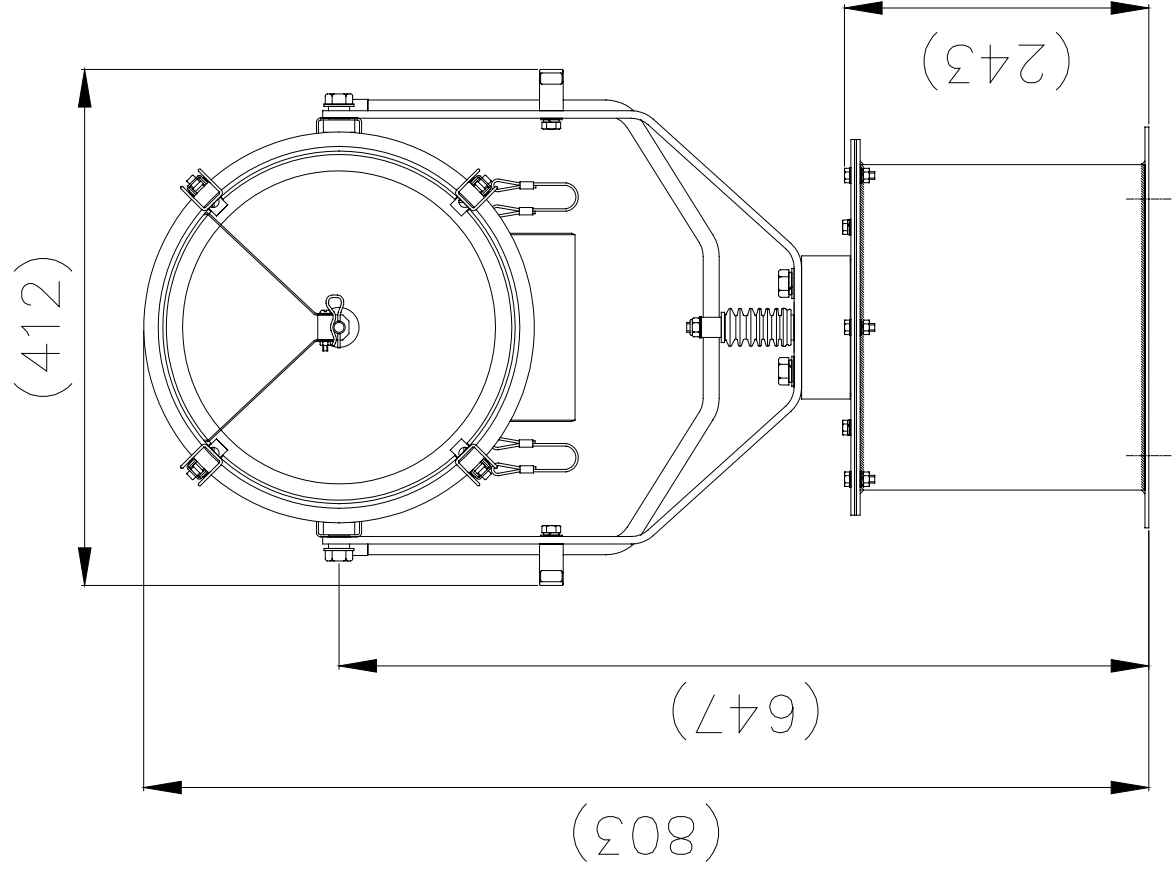
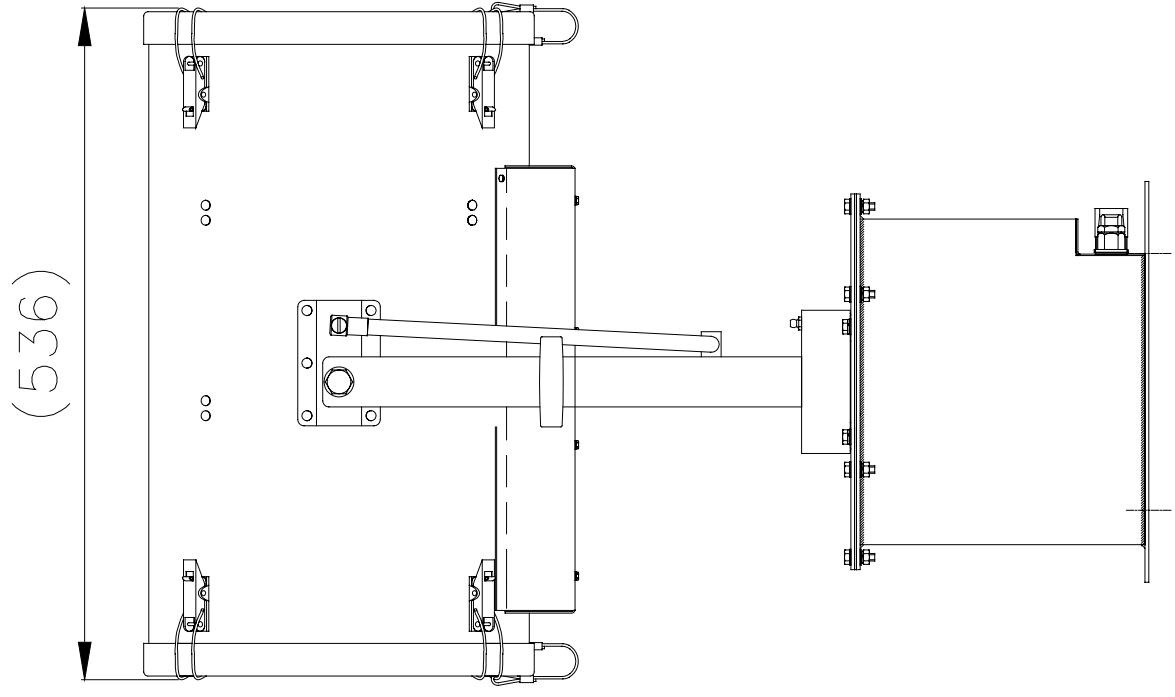

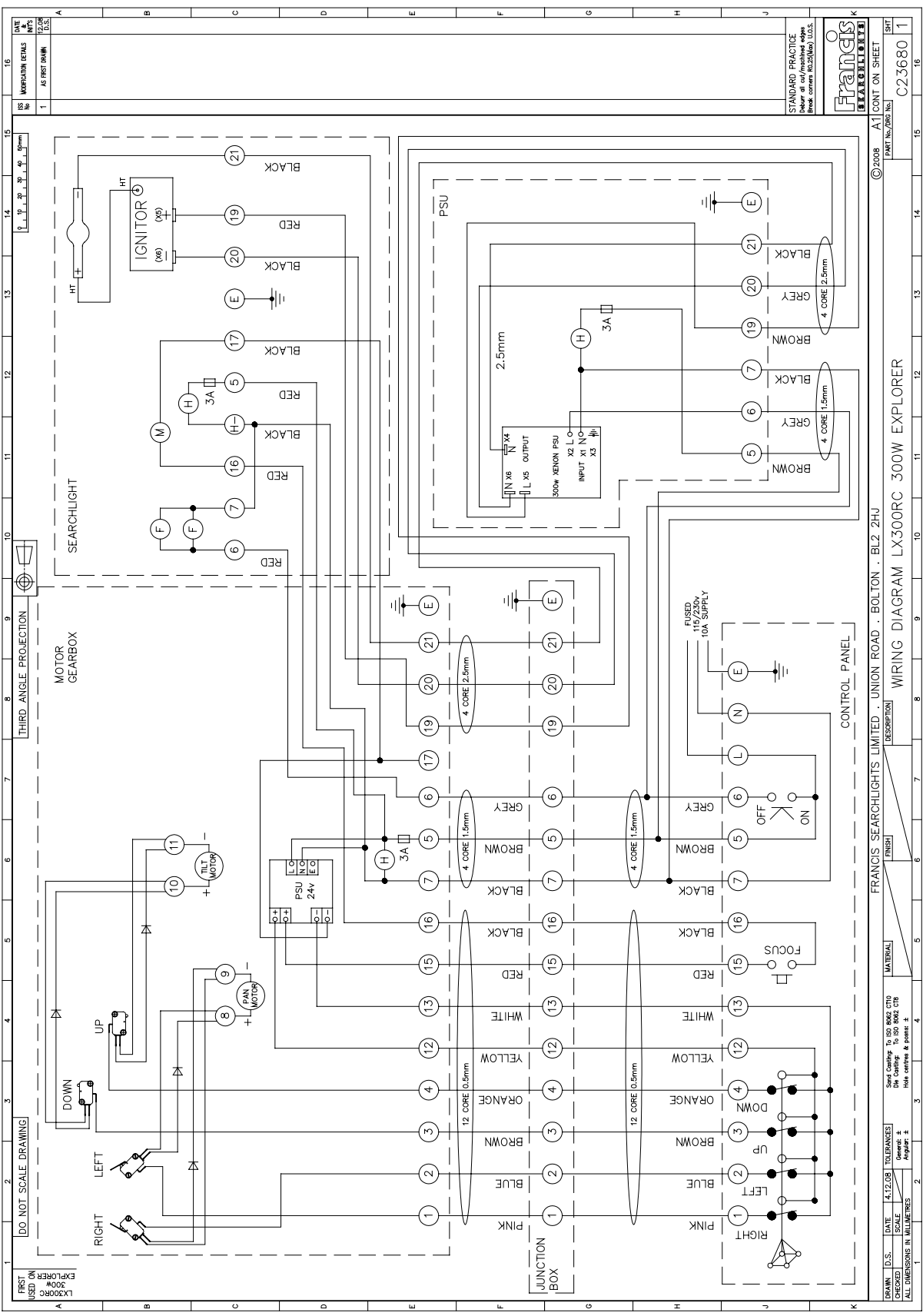

DRAWN: D.S. DATE: 4.12.08 TOLERANCES:
 CHECKED: M.S. DATE: 11.02.09 DIMENSIONS: TO UNLESS OTHERWISE SPECIFIED
 ALL DIMENSIONS IN MILLIMETRES
 MATERIAL:
 FINISH:
 DESCRIPTION: FRANCIS SEARCHLIGHTS LIMITED - UNION ROAD - BOLTON - BL2 2HU
 WIRING DIAGRAM LX300RC 300W EXPLORER
 PART No./REV. No.:
 © 2008 A11 CONT ON SHEET
 SHEET: C23680 1

STANDARD PRACTICE
 Drawn at out/finished edge
 Block corners 10:25mm U.C.S.

FRANCIS SEARCHLIGHTS

FIRST USED ON LX300RC EXPLORER 300W

DO NOT SCALE DRAWING

THIRD ANGLE PROJECTION

MOTOR GEAR BOX

SEARCHLIGHT

IGNITOR

PSU

JUNCTION BOX

CONTROL PANEL

10 – Spare Parts List

The following spare parts can be ordered directly from the manufacturer:

Part Number	Description
D21908	300w Xenon Lamp
C14143-00	Switch - On/Off
C14142-00	Switch - Focus
C20645-00	Front glass
C20567-00	Front glass gasket
C16410-00	Motor - Remote Focus
C22268-01	Breather Unit
C14444-00	Joystick
C24132-01	Fan (240v)
C24450-01	Fan (115v)
C21909-00	Reflector
C21907-00	PSU / Ignitor
C21924-00	Fan (PSU)
C23277-00	Barrel, PSU and Motor Gearbox heater

Motor Gearbox Spares

C23259-01	Pan Motor Assy
C23267-01	Tilt Motor Assy
C22380-00	Microswitch no lever
C22382-00	Microswitch with lever
C23234-00	Pedestal Sealing Gasket
C23530-00	P.S.U.

In order to prolong the life and performance of your product, we recommend that you only specify Francis Searchlights spare parts. This will ensure that any warranties on your equipment will not be invalidated.

When ordering spare parts please contact the Sales Department at Francis Searchlights Limited. Please quote searchlight model and serial number at all times. This will enable a fast response to your spares' requirements.