



User Instruction & Installation Manual

FH300 575 Watt Metal Halide Searchlight



Product Reference Number:

A2876 – 240v DECK
A2878 – 240v DECK PEDESTAL

A2877 – 240v CABIN
A2879 – 240v CABIN PEDESTAL

Manufacturer's details:

Francis Searchlights Ltd
Union Road, Bolton
Lancashire, BL2 2HJ, UK
Tel: +44 (0) 1204 558960
Fax: +44 (0) 1204 558979
<http://www.francis.co.uk>
E-mail: sales@francis.co.uk

Distributor details:

Manual Part Number: C20377
10.11.18 Issue: 11

CONTENTS

- 1 - Introduction
- 2 - Safety Precautions
- 3 - Technical Information
- 4 - Unpacking and Installation Instructions
- 5 - Electrical Installation
- 6 - Operating Instructions
- 7 - Fault Finding
- 8 - Maintenance and Servicing
- 9 - Wiring Diagrams & General Assemblies
- 10 - Spare Parts List

1 - Introduction

It is imperative that this manual is read carefully and understood before installing your equipment. For your future reference please keep this manual in a safe place.

Thank you for specifying a product from the Francis Searchlights range. All Francis products are designed to give complete customer satisfaction and are manufactured to the highest engineering standards in order to ensure optimum performance and service life.

The Francis Metal Halide range combines features proven over many years service in the most hazardous conditions in both marine and land installations.

In order to prolong the life and performance of your product, we recommend that you only specify Francis Searchlights spare parts. This will also ensure that any warranties on your equipment will not be invalidated. Information on spares ordering and parts is provided in this manual.

Should you ever need to contact Francis Searchlights Ltd. regarding your equipment, please quote the Product Serial Number at all times.

2 - Safety Precautions

The following instructions must be adhered to, in order to ensure a safe working environment and the safety of the user.

Note: When unpacking or manoeuvring the searchlight into its fixing position, suitable lifting points must be used in order to prevent damage to the equipment or personal injury.

- Because of the high internal pressure within the lamp, there is a risk of explosion in either a hot or cold state;
- During operation this lamp emits intense UV radiation which is harmful to the eyes and skin. Suitable protection should be worn;
- The high luminance of the arc can cause severe damage to the eye if viewed directly. ALWAYS wear suitable protective goggles when viewing the lamp;
- Always use protective sleeves supplied with the lamp;
- Should it be necessary to examine the lamp with the front bezel removed, always use a protective shield and wear goggles to ensure a safe working environment;
- Searchlights get hot. Never touch the unit when lit and always allow 15 to 20 minutes for cooling down after turning the searchlight off;
- Never place anything on or cover the searchlight when in use;
- Ensure the lamp has cooled sufficiently before removal;
- If undue force appears necessary to remove the lamp, the equipment should be inspected by a competent person or contact the manufacturer;
- When disposing of lamps, return the lamp, via the supplier, to the lamp manufacturer in its complete packaging;
- Due to the vast range of lamps available it may appear possible that more powerful lamps can be used in the equipment than for which it was designed. Even when the unit will physically accept a higher wattage or voltage lamp, this substitution is not recommended and is dangerous. This action will also void any warranties on the equipment.
- Always refer to the lamp manufacturer's technical data when dealing with lamps.

3 – Technical Information

This product has been designed to operate in accordance with the product specification. The FH300 575 watt searchlight has the following features:

- All marine grade materials and fixings;
- Parabolic glass reflector;
- Powder coated paint finish;
- Full 450° horizontal rotation;
- Vertical movement +35° to -25°;
- Remote focus facility (optional);
- Internal self-regulating heater. (Optional);
- Instant lamp re-strike. No cooling down time required;
- Economical 1000 hour lamp life;
- Toughened super clear Optiwhite front glass;
- Luminous flux 49000;
- Colour temperature 6000K;
- Searchlight to IP56 & Control Gear protected to IP66;

The searchlight also performs to the following optical data:

- Metal Halide light source G22;
- Lamp Wattage - 575 Watts;
- Supply voltage - 220/240V 50/60Hz 1 phase;
- Peak Beam Candlepower – 13,600,000 lux;
- Range – 3685 metres;
- Divergence – 2.5° Spot to 15° flood;
- Temperature range: -50°C (with heaters fitted);

In order that the searchlight operates correctly it is imperative that competent personnel are responsible for the installation, operation and servicing of this equipment. Failure to adhere to this advice may cause premature failure or incorrect operation of the searchlight, which may damage the equipment or cause personal injury.

4 - Unpacking and Installation Instructions

The following instructions should be read and fully understood prior to installing the equipment to ensure that the correct procedures are followed, and all safety precautions are observed.

Note: If the equipment has been in storage for a considerable amount of time, it is advisable to conduct a routine maintenance check on all parts before installation.

Safety Precautions

This equipment should not be connected to an electrical supply before being installed. Installation procedures should be adhered to in order to ensure a safe working environment and reduce the risk of damage or personal injury.

Preparing the Mounting Position

Mark out and drill the fixing holes through the deck. If anti-vibration mounts are to be fitted, the fixing holes for the mounts should also be marked out and drilled. Prior to manoeuvring the searchlight into its' fixing position, the AV mounts should be fitted to the base. When in the desired position, bolt the searchlight firmly down.

5 - Electrical Installation

For safety purposes, only competent personnel should perform the electrical installation. All equipment should be installed to current Electrical Regulations and Standards.

In order to obtain the maximum light output from the searchlight, it is essential that the full operating voltage of the lamp fitted be applied to the lampholder contacts.

Method of Electrical Connection

- 1) Disconnect the supply before working on the electrical system;
- 2) The searchlight must be connected to a fused electrical supply, using suitably sized cable;
- 3) If the searchlight is located a considerable distance from the supply, provision must be made in the cable size in order to overcome the voltage drop.

The Control Gear should NOT be positioned no more than 5 meters away from the Searchlight.

The following table below indicates the maximum length of cable to be used for the AC supply cable (Butyl HO7 RN-F) to the control gear:

Searchlight	240v 575w
Cable Size (mm ²)	Distance Max
1.5	50 MTRS
2.5	85 MTRS
4.0	137 MTRS
6.0	204 MTRS
10.0	361 MTRS

- 4) Whenever possible cable terminations should be made below deck and with approved terminal devices;
- 5) If a spare auxiliary fuse or circuit breaker is not available, one of the correct type and rating should be fitted and connected to a positive supply. It is advisable to locate a bus bar or main connection and avoid any direct connection to the supply;
- 6) For 110/220v AC products, the following colour coding system should be used for the customer supply cable:

Brown - Live
Blue - Negative
Green/Yellow - Earth

Note: This equipment must be earthed.

Installation Guideline

A typical installation and connection routine for the FH300 searchlight is as follows:

Referring to wiring diagram C27547, a supply is fed into the control gear enclosure, which then provides a common feed to the control gear and the searchlight.

Cables required to be connected by the customer: -

5 cores 1.5mm cable from the Searchlight to the Control Gear,

(Customer may need to provide a suitable junction box to this cable, 3 metres supplied).

The Mains cable to the Control Gear is to be supplied by the customer.

A typical installation and connection routine for the FH300 Remote Focus searchlight is as follows:

Referring to wiring diagram C27676, a supply is fed into the control gear enclosure, which then provides a common feed to the control gear, control panel and searchlight.

Cables required to be connected by the customer: -

5 cores 1.5mm cable from the Searchlight to the Control Gear.

5 cores 1.5mm cable from the Control Panel to the Control Gear.

(Customer may need to provide a suitable junction box to extend these two cables, 3 metres supplied).

The Mains cable to the Control Gear is to be supplied by the customer.

6 - Operating Instructions

This equipment is designed for use out of doors, in free air. Never place anything on or cover the searchlight when in use as this may present a hazard.

The beam of the searchlight can be adjusted to give a variety of beam types. Using the lampholder focus wheel, the desired beam can be achieved for any particular application.

On the Remote Focus model, the beam of the searchlight can be adjusted to give a variety of beam types. Using the yellow remote focus button on the Control Unit, the desired beam can be achieved for any particular application. The beam will move continuously through 'spot' to 'flood'. In order to fix the beam type; simply release the button at the desired position.

Using the template provided mark out and drill the fixing holes through the deck or cabin roof. In case of cabin control models, a centre hole is also required to allow the mechanism to pass through.

On an uneven surface when bolting down the searchlight it is necessary to use a suitable sealant, such as silicone, in order to ensure weather proofed joint.

The optional heater specified on this equipment is self-regulating and will shut off when the dew point temperature is reached.

This product should not be used for any purpose other than for which it was designed. Any modifications to the product should not be undertaken without consulting the manufacturer.

Setting to Work

Safe service in use necessitates the strict observance of the following precautions.

- Any article fabricated from quartz or glass is inherently fragile and care should therefore be taken, at all times, when handling lamps;
- Eye protection must be worn when handling lamps that have been removed from their packaging materials. The protective sleeve should not be removed from the lamp for safety reasons, as there is a remote possibility of the lamp shattering violently, especially if it is subjected to mechanical shock or vibration;
- Ensure that the power rating of the lamp to be fitted is suitable for the lamphouse and power supply equipment;
- Always isolate the equipment from the supply before inserting a lamp;
- Before inserting the lamp ensure that all contacts are clean. Contacts must be renewed at the slightest sign of corrosion. Sanding or filing down corroded areas is not recommended as this will only make the conducting surface between the pin and lampholder smaller, thus causing the lamp to overheat;
- Do not twist or bend the fused quartz bulb when fitting the lamp as mechanical stresses MUST be avoided;
- When inserting or removing a lamp, always hold it securely by its' base in order to prevent breakage between base and bulb;
- The lampholder must not exercise mechanical tensions on the lamp, neither during insertion or operation. Contacts must not discolour during use;
- For safety reasons, the lamp should be replaced once it has reached its' average life, and not later than 1.25 times the stated life. With continuing use the risk of the lamp exploding increases due to alterations within the quartz;
- Before the protective sleeve is removed, suitable protection must be worn i.e face mask and gloves with wrist protection;
- Never touch the quartz bulb with bare hands, as fingerprints will make the glass cloudy and cause a severe loss of light. This may also cause recrystallisation and thus weaken the bulb material. Should the bulb be inadvertently touched, remove fingerprints with methylated spirit and a clean, soft paper towel. The bulb should then be wiped with distilled water. NOTE: ALWAYS WEAR MASK AND GLOVES DURING CLEANING);
- All packaging and the protective sleeve must be retained for re-use. Whenever removing a lamp, the protective sleeve must always be used for safety reasons;

In all circumstances the lamp manufacturer's data should be referred to when dealing with lamps.

7- Fault Finding

All fault finding must be conducted by a competent person or qualified Electrical Engineer.

Failure of Lamp to ignite

In the event of the lamp failing to light the following steps should be taken:

- 1) Check that the mains supply is connected to the input of the ballast gear and check all connections as per the wiring diagram. On operation if the lamp does not light, switch off mains supply and check all fuses;
- 2) Check the searchlight head. On your command get an operator to switch on the light for approximately 2 seconds. During this time listen for any noise (cracking or hissing) coming from within the barrel. If this arcing is heard switch off the supply at the mains. Remove the rear bezel to expose the two supply leads from the ignitor to the lamp. Using a dry cloth wipe these leads to remove any dust, moisture or condensation that may have formed around the inside of the barrel. Replace the rear bezel, ensure the latches are secure, and perform the check again, listening for the cracking. If the lamp still fails to ignite, switch off at the mains and replace the lamp in accordance with the safety procedures within the manual and the manufacturer's information.

Any further tests to be carried out with regards to lamp failure must be conducted by a competent electrical engineer and should not be carried out in an explosive atmosphere.

- 3) Before a metal halide lamp will ignite, the electrically insulated gas between the electrodes must be ionised. This is done by the ignitor which produces a high frequency voltage (up to 30,000 volts or higher). Switching the lamp on activates the ignitor. A cracking or hissing noise should be heard. The ignitor is housed within the rear of the searchlight barrel. If found to be faulty a new ignitor must be fitted.

Failure of Remote Focus Facility (Optional facility)

The remote focus mechanism is controlled by a small electric motor situated on the lampholder assembly within the searchlight barrel. If the focus of the light fails, the following procedure should be adopted:

- 1) Remove the front bezel from the searchlight barrel and examine focus mechanism. If parts have become loose, tighten fasteners. The mechanism operates on a cam action and this should be checked for correct positioning;
- 2) If the mechanism is okay, check the supply to the motor. This can be done by simply placing a multimeter across the motor terminals;
- 3) If supply is present, this indicates that the motor has failed. Replace the focus motor ensuring that the assembly is correct;
- 4) If no supply is present, check the transformer in the control unit. Using a multimeter check the supply into and from the transformer. If found to be faulty, replace the transformer and check operation of focus mechanism.
- 5) If no supply is present there is a fault at the mains or the internal wiring of the control gear. This should be examined and rectified accordingly.

[Back To Top](#)

8 - Maintenance and Servicing

In order to prolong the service life and performance of your searchlight, the following maintenance guidelines are recommended:

- Maintenance checks should be conducted before every voyage or at least every three months;
- Before checking, disconnect the equipment from the supply;
- Visually inspect the condition of the equipment;
- Any major or minor structural damage should be rectified immediately in order to reduce sympathetic wear;
- After inspection it may be necessary to clean the inside of the searchlight. The following procedure should be adhered to:
 - Remove the front bezel;
 - Clean the front glass inside and out using a proprietary glass cleaner;
 - Clean the reflector if required;
 - Check the reflector mounting gaskets. If signs of corrosion or damage are evident, replace as necessary;
 - Ensure that the lampholder is free from corrosion or other damage;
 - Check earth point for conductivity;
- It is advisable to check all seals and gaskets for signs of degradation. Renew if necessary;
- Upon completing all maintenance requirements, the searchlight should be tested for full working order (approximately 20 minutes).
- Every six months the external movement mechanisms i.e. lockwheels, elevation and pan mechanisms, should be lightly lubricated.

If in any doubt as to the correct servicing procedures to adopt please contact your distributor/agent or the manufacturer who will be able to advise the best course of action for your product.

9 - Wiring Diagrams & General Assemblies

Drawing Number	Description
C27547	Wiring diagram (Manual focus)
C27676	Wiring diagram (Remote focus)
X4946	FH300 Deck
X4947	FH300 Cabin
X4948	FH300 Deck Pedestal
X4949	FH300 Cabin Pedestal
C21294	Control Gear Assembly
C20292	Remote Focus Control Unit

DO NOT SCALE DRAWING

THIRD ANGLE PROJ

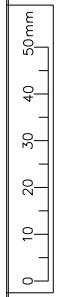

ISS No	1	MODIFICATION DETAILS	AS FIRST DRAWN	DATE & INITS	5.17 LW
--------	---	----------------------	----------------	--------------	---------

FIRST USED ON
FH575W
A2876/79

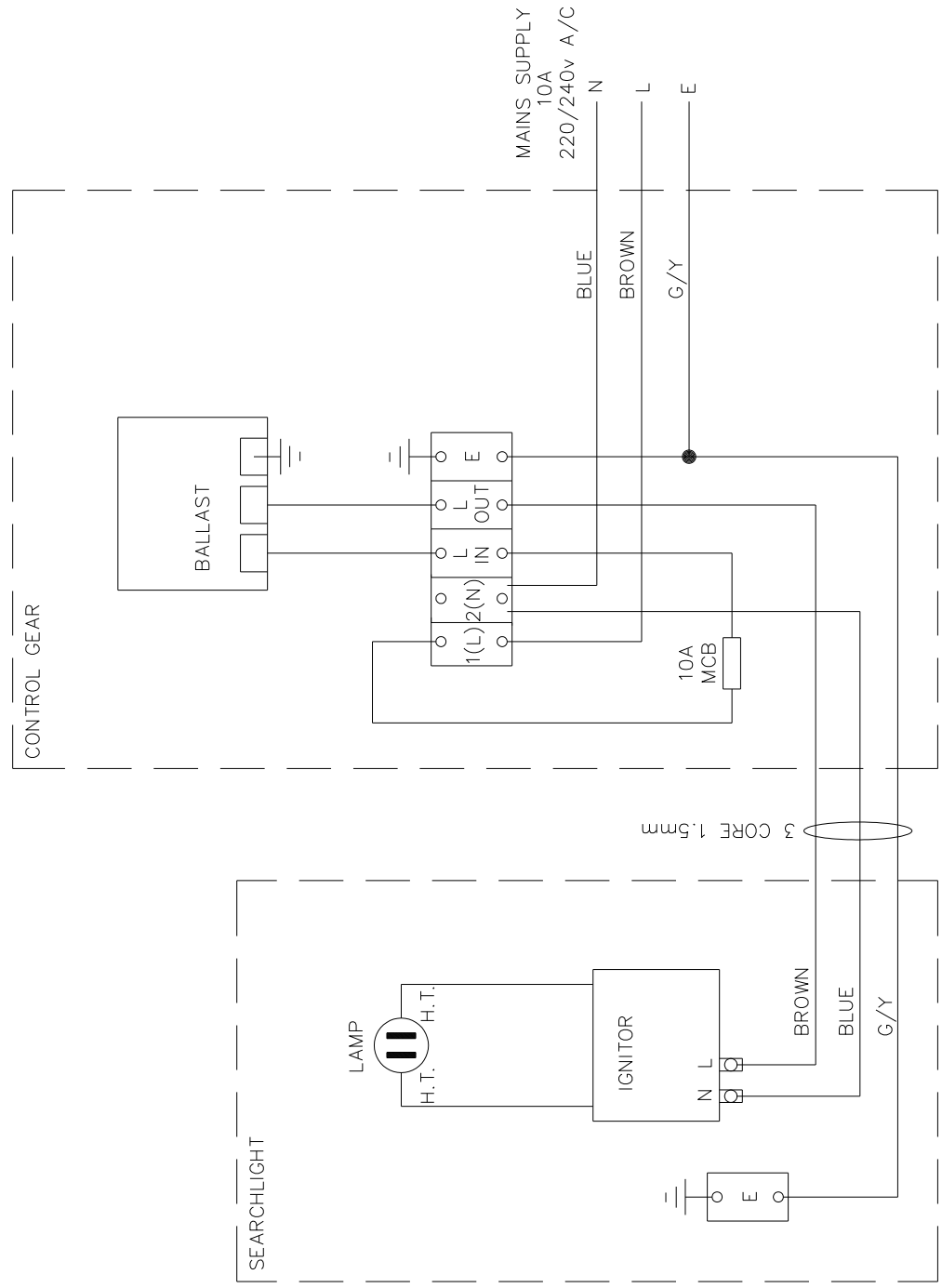

STANDARD PRACTICE
Deburr all cut/machined edges
Break corners R0.25(Max) U.O.S.
TOLERANCES U.O.S. :-
General: ±
Angular: ±
Hole centres & posns: ±
Sand Casting: To ISO 8062 CT10
Die Casting: To ISO 8062 CT8

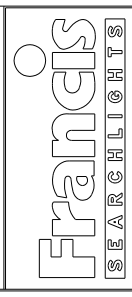

DRAWN LW		DATE	5.17	MATERIAL	FINISH		DESCRIPTION	
CHECKED		SCALE		PART No./DRG No.		C27547		SHT
ALL DIMENSIONS IN MILLIMETRES				FRANCIS SEARCHLIGHTS LIMITED, UNION ROAD, BOLTON, BL2 2HJ		©2017 A3 CONT ON SHEET		1
				WIRING DIAGRAM (LIMELITE IGN)				

FIRST USED ON
FH300C
RF 575w

DO NOT SCALE DRAWING

THIRD ANGLE PROJECTION



IS No	MODIFICATION DETAILS	
	DATE	INIT'S
1	AS FIRST DRAWN	
	D.S.	

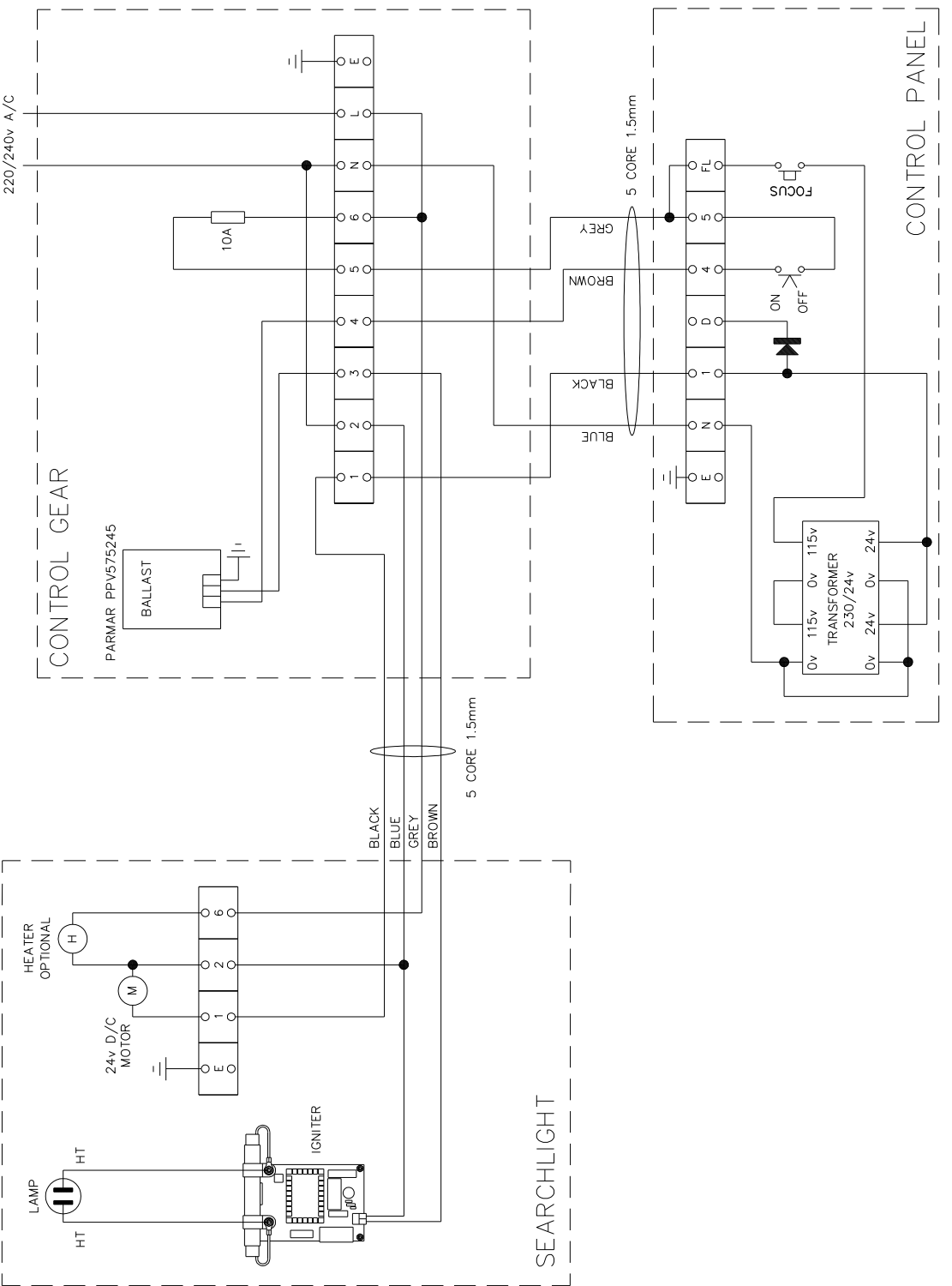

STANDARD PRACTICE
Debur all cut/machined edges
Break corners R0.25(Max) U.O.S.

Francis
SEARCHLIGHTS

©2018 A2 CONT ON SHEET
PART No./DRG No. C27676
SHT 1

FRANCIS SEARCHLIGHTS LIMITED . UNION ROAD . BOLTON . BL2 2HJ	DESCRIPTION
575w RF WIRING DIAGRAM	
FINISH	
MATERIAL	
Sand Casting: To ISO 8062 CT10 Die Casting: To ISO 8062 C18 Hole centres & posns: ±	
TOLERANCES	
1:18 General: ± Angular: ±	
DATE	
SCALE	
ALL DIMENSIONS IN MILLIMETRES	

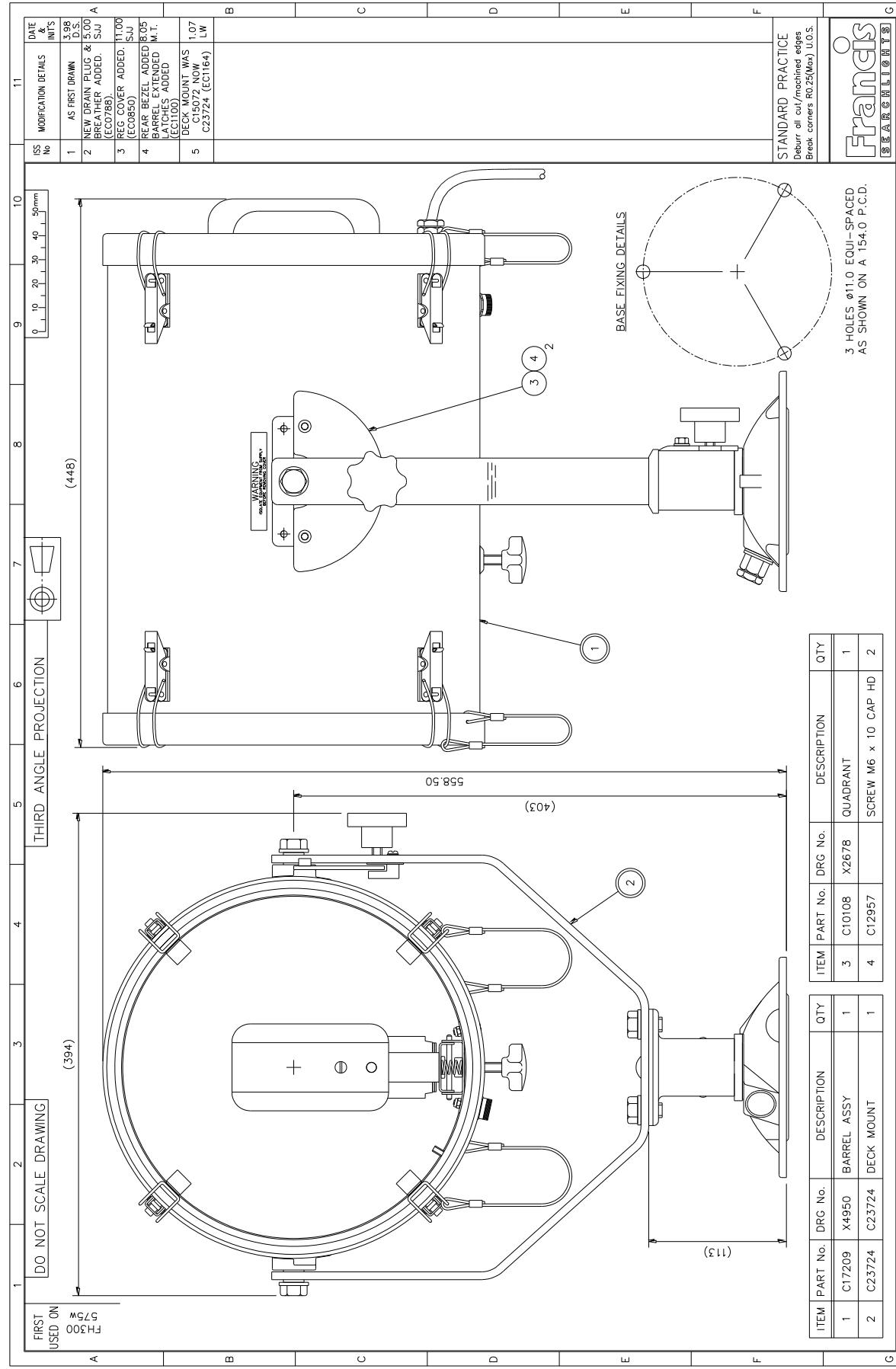

DO NOT SCALE DRAWING

THIRD ANGLE PROJECTION

50mm

1 2 3 4 5 6 7 8 9 10 11

A B C D E F

ISS No	MODIFICATION DETAILS	DATE & INIT'S
1	AS FIRST DRAWN	3.98 D.S.
2	NEW DRAIN PLUG & BREACHER ADDED.	5.00 S.J.J.
3	ECG/788 & ECG/850 ADDED.	11.00 S.J.J.
4	BEAR BEZEL ADDED & BARREL EXTENDED. LATCHES ADDED.	8.05 M.T.
5	DECK MOUNT WAS C15072 NOW C23724 (EC1100)	1.07 LW

(448)

(394)

(403)

558.50

(113)

WARNING
DO NOT SCALE DRAWING

BASE FIXING DETAILS

3 HOLES ϕ 11.0 EQUI-SPACED AS SHOWN ON A 154.0 P.C.D.

ITEM	PART No.	DRG No.	DESCRIPTION	QTY
1	C17209	X4950	BARREL ASSY	1
2	C23724	C23724	DECK MOUNT	1
3	C10108	X2678	QUADRANT	1
4	C12957		SCREW M6 x 10 CAP HD	2

STANDARD PRACTICE
Debur all cut/machined edges
Break corners R0.25(Max) U.O.S.

Francis
SEARCHLIGHTS

© 1998 A2 CONT ON SHEET

PART No./DRG No. A2876/X4946

1998 A2 CONT ON SHEET

FRANCIS SEARCHLIGHTS LIMITED . UNION ROAD . BOLTON . BL2 2HJ

Sand Casting: To ISO 8062 CT10
Die Casting: To ISO 8062 C18
Hole centres & posns: \pm

FINISH

DESCRIPTION

FH300D 575w G.A.

1

FIRST USED ON FH300 575w

1 2 3 4 5 6 7 8 9 10 11

A B C D E F

G

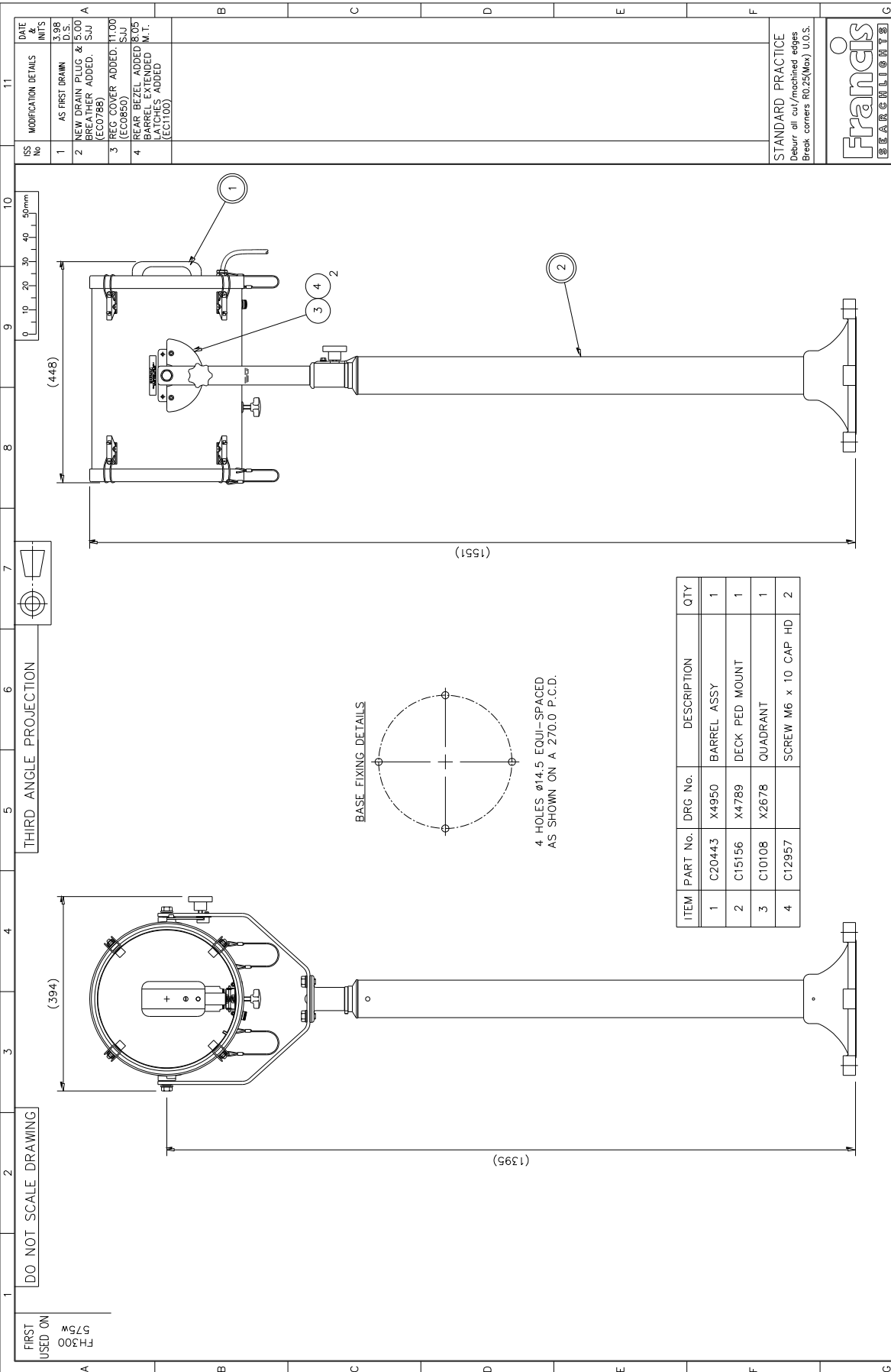

ISS No	DATE & INT'S	MODIFICATION DETAILS
1	3.98 D.S.	AS FIRST DRAWN
2		NEW DRAIN PLUG & 15.00mm DRAIN TUBE ADDED. FSJ
3		REC COOLER ADDED: 11700 (EC0985)
4		REAR BEZEL ADDED: R205 BARREL EXTENDED M.T. LATCHES ADDED (EC1100)

STANDARD PRACTICE
 Deburr all cut/machined edges
 Break corners R0.25(Max.) U.O.S.



ITEM	PART No.	DRG No.	DESCRIPTION	QTY
1	C20443	X4950	BARREL ASSY	1
2	C15156	X4789	DECK PED MOUNT	1
3	C10108	X2678	QUADRANT	1
4	C12957		SCREW M6 x 10 CAP HD	2

DO NOT SCALE DRAWING

THIRD ANGLE PROJECTION

FIRST USED ON
 FH300
 575w

FRANCIS SEARCHLIGHTS LIMITED . UNION ROAD . BOLTON . BL2 2HU

© 1998 A2 CONT ON SHEET

Part No./DRG No. A2878/X4948

SH T 1

FRANCIS SEARCHLIGHTS LIMITED

Scale: To ISO 8062 CT10
 To ISO 8062 CT8

General: ±
 Angular: ±

Hole centres & posns: ±

FINISH

DESCRIPTION

FH300DP 575w G.A.

11 10 9 8 7 6 5 4 3 2 1

THIRD ANGLE PROJECTION

DO NOT SCALE DRAWING

FIRST USED ON
FH300
575w

ISS No	MODIFICATION DETAILS	DATE IN TS
1	AS FIRST DRAWN	1993
2	NEW DRAIN PLUG & 15.00 BREATHER ADDED. (EC0788)	15.00 S.U.
3	REG COVER ADDED. 11.00 (EC0850)	S.U.
4	REAR BEZEL ADDED 8.05 BARREL EXTENDED 10.05 NOTCHES ADDED (EG1186)	M.T.

ITEM	PART No.	DRG No.	DESCRIPTION	QTY
1	C20443	X4950	BARREL ASSY	1
2	C20298	C20298	CABIN PED TRAINER MOUNT	1

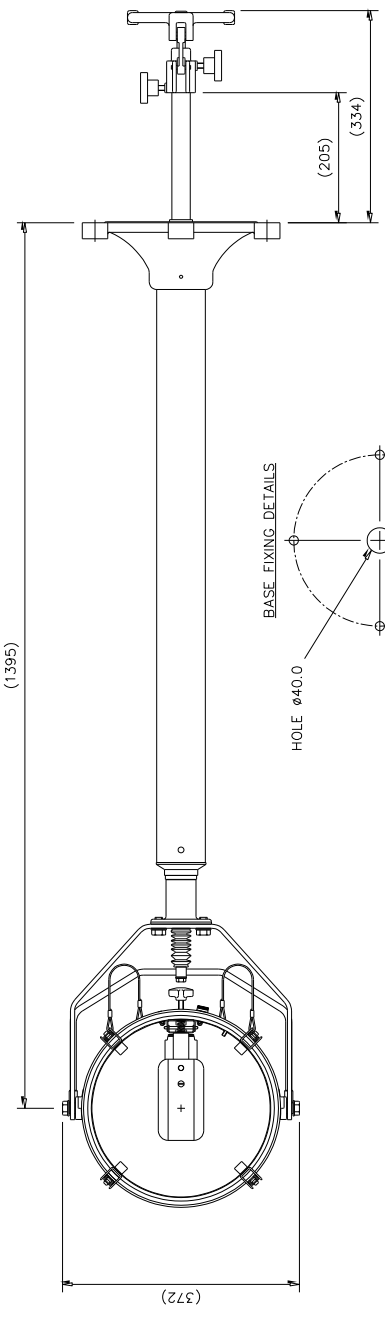
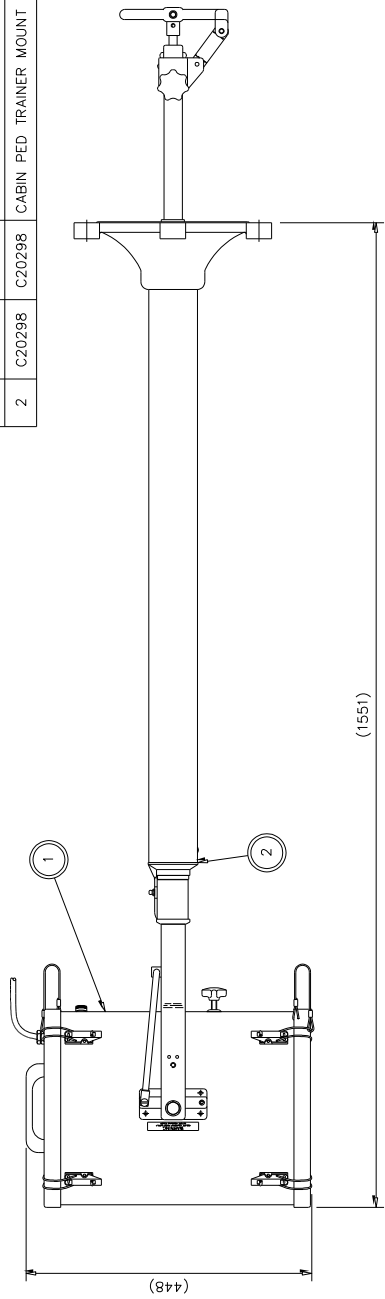

STANDARD PRACTICE
Deburr all cut/machined edges
Break corners R0.25(Max.) U.O.S.

Francis
SEARCHLIGHTS

© 1998 A2
CONT ON SHEET

FRANCIS SEARCHLIGHTS LIMITED . UNION ROAD . BOLTON . BL2 2HU

DESCRIPTION
FH300CP 575w G.A.

FINISH
MATERIAL
Sand Casting: To ISO 8062 CT10
Die Casting: To ISO 8062 C18
Hole centres & posns: ±

TOLERANCES
General: ±
Angular: ±

DRAWN
CHECKED
ALL DIMENSIONS IN MILLIMETRES

D.S.
SCALE
DATE
1:5

3.98

1998 A2

CONT ON SHEET

PART No./DRG No.
A2879/X4949

SHT
1

11

11
10
9
8
7
6
5
4
3
2
1

DATE & UNITS
3.98 D.S.
6.98 D.S.
6.98 D.S.
7.99 R.J.M.
4.00 S.U.J.
6.01 D.S.
6.05 M.T.
8.05 M.T.
10.06 M.T.
10.06 D.S.
4.08 L.W.
5.08 D.S.
1.12 D.S.
5.13 L.W.
5.13 L.W.
1.16 L.W.
1.18 D.S.
E
F
G

ISS No
1
2
3
4
5
6
7
8
9
10
11
12
13
14
15
16
17

MODIFICATION DETAILS
AS FIRST DRAWN
BALLAST BRKT ADDED (EC0652)
CONTROL GEAR ASSY 2.99 REVISED. (EC0711)
ITEM 7 B.I.L.W.D. DELETED (EC0736)
ITEM REFS REVISED 4.00 M.T. DESIG. C21294 & C21295 ADDED TO DRG. (EC0794)
PART No. CORRECTION 04.01 R.L.
BALLAST MOD. (EC0936)
EXTRA EARTH ADDED (EC1097)
GLANDS & TERMINALS CHANGED FOR NEW IGNITOR (EC1100)
REDUCED ENC. SIZE (EC1144) WAS C20394
C10158 HAS REPLACED C12415
C24230 ADDED (EC1184)
FUSE 10A WAS 20A (EC1378)
TERMINAL BLOCK NOW FREE ISSUED (EC1486)
FUSE & CARRIER REMOVED MCB ADDED (EC1602)
TERMINAL BLOCK ADDED (EC1608)
BROUGHT IN-LINE WITH DETAIL (EC0000)

STANDARD PRACTICE
Debur all cut/machined edges
Break corners R0.25(Max) U.O.S.

Francis
SEARCHLIGHTS

© 1998 A2 CONT ON SHEET
PART No./DRG No. C21294 1

DRG No. 575W CONTROL GEAR ASSY

11
10
9
8
7
6
5
4
3
2
1

THIRD ANGLE PROJECTION

DO NOT SCALE DRAWING

FIRST USED ON
M 5750
M 5750

VIEW WITH LID REMOVED

(182)
(191)
(305)

12 2
11 2
10 2
9 2
8 4
7 2
6 2
5 2
4 2
3 2
2 2
1 2

C24230 3 OFF
C21294 2 OFF

C21294 ONLY
C24230 ONLY

2 OR 6

FRANCIS SEARCHLIGHTS LIMITED . UNION ROAD . BOLTON . BL2 2HU

Send Coasting: To ISO 8062 C10 [MATERIAL]
Die Coasting: To ISO 8062 C18
Hole centres & posns: ±

TOLERANCES
General: ±
Angular: ±

SCALE 1:2
ALL DIMENSIONS IN MILLIMETRES

FINISH

DESCRIPTION

ITEM PART No. DRG No. DESCRIPTION QTY

1	C23639	C23639	CHASSIS PLATE S/ASSY	1	1
2	C23640	C23640	ENCLOSURE DRILLING	1	1
3	C23641	C23641	ENCLOSURE DRILLING	1	1
4	C27064	C24143	DIN RAIL	1	1
5	C15450		M25 GLAND	1	1
6	C24231	C24231	ENCLOSURE DRILLING	1	1
7	C10158		M20 GLAND	2	3
8	C20537		BALLAST	1	1
9	C26986		10AMP MCB	1	1
10	C10213		M6 x 12 PAN HD SCREW	6	6
11	C10554		M6 S/C SPRING WASHER	6	6
12	C06997		M6 PLAIN WASHER	6	6
13	C15133		TERMINAL BLOCK	10	10
14	C10129		M3 x 20 BTN HD SCREW	2	2
15	C10747		M3 S/C SPRING WASHER	2	2
16	C08028		M3 PLAIN WASHER	2	2
17	C05298		M3 FULL NUT	2	2

11
10
9
8
7
6
5
4
3
2
1

FRANCIS SEARCHLIGHTS LIMITED . UNION ROAD . BOLTON . BL2 2HU

Send Coasting: To ISO 8062 C10 [MATERIAL]
Die Coasting: To ISO 8062 C18
Hole centres & posns: ±

TOLERANCES
General: ±
Angular: ±

SCALE 1:2
ALL DIMENSIONS IN MILLIMETRES

FINISH

DESCRIPTION

ITEM PART No. DRG No. DESCRIPTION QTY

1	C23639	C23639	CHASSIS PLATE S/ASSY	1	1
2	C23640	C23640	ENCLOSURE DRILLING	1	1
3	C23641	C23641	ENCLOSURE DRILLING	1	1
4	C27064	C24143	DIN RAIL	1	1
5	C15450		M25 GLAND	1	1
6	C24231	C24231	ENCLOSURE DRILLING	1	1
7	C10158		M20 GLAND	2	3
8	C20537		BALLAST	1	1
9	C26986		10AMP MCB	1	1
10	C10213		M6 x 12 PAN HD SCREW	6	6
11	C10554		M6 S/C SPRING WASHER	6	6
12	C06997		M6 PLAIN WASHER	6	6
13	C15133		TERMINAL BLOCK	10	10
14	C10129		M3 x 20 BTN HD SCREW	2	2
15	C10747		M3 S/C SPRING WASHER	2	2
16	C08028		M3 PLAIN WASHER	2	2
17	C05298		M3 FULL NUT	2	2

11
10
9
8
7
6
5
4
3
2
1

FRANCIS SEARCHLIGHTS LIMITED . UNION ROAD . BOLTON . BL2 2HU

Send Coasting: To ISO 8062 C10 [MATERIAL]
Die Coasting: To ISO 8062 C18
Hole centres & posns: ±

TOLERANCES
General: ±
Angular: ±

SCALE 1:2
ALL DIMENSIONS IN MILLIMETRES

FINISH

DESCRIPTION

ITEM PART No. DRG No. DESCRIPTION QTY

1	C23639	C23639	CHASSIS PLATE S/ASSY	1	1
2	C23640	C23640	ENCLOSURE DRILLING	1	1
3	C23641	C23641	ENCLOSURE DRILLING	1	1
4	C27064	C24143	DIN RAIL	1	1
5	C15450		M25 GLAND	1	1
6	C24231	C24231	ENCLOSURE DRILLING	1	1
7	C10158		M20 GLAND	2	3
8	C20537		BALLAST	1	1
9	C26986		10AMP MCB	1	1
10	C10213		M6 x 12 PAN HD SCREW	6	6
11	C10554		M6 S/C SPRING WASHER	6	6
12	C06997		M6 PLAIN WASHER	6	6
13	C15133		TERMINAL BLOCK	10	10
14	C10129		M3 x 20 BTN HD SCREW	2	2
15	C10747		M3 S/C SPRING WASHER	2	2
16	C08028		M3 PLAIN WASHER	2	2
17	C05298		M3 FULL NUT	2	2

11
10
9
8
7
6
5
4
3
2
1

FRANCIS SEARCHLIGHTS LIMITED . UNION ROAD . BOLTON . BL2 2HU

Send Coasting: To ISO 8062 C10 [MATERIAL]
Die Coasting: To ISO 8062 C18
Hole centres & posns: ±

TOLERANCES
General: ±
Angular: ±

SCALE 1:2
ALL DIMENSIONS IN MILLIMETRES

FINISH

DESCRIPTION

ITEM PART No. DRG No. DESCRIPTION QTY

1	C23639	C23639	CHASSIS PLATE S/ASSY	1	1
2	C23640	C23640	ENCLOSURE DRILLING	1	1
3	C23641	C23641	ENCLOSURE DRILLING	1	1
4	C27064	C24143	DIN RAIL	1	1
5	C15450		M25 GLAND	1	1
6	C24231	C24231	ENCLOSURE DRILLING	1	1
7	C10158		M20 GLAND	2	3
8	C20537		BALLAST	1	1
9	C26986		10AMP MCB	1	1
10	C10213		M6 x 12 PAN HD SCREW	6	6
11	C10554		M6 S/C SPRING WASHER	6	6
12	C06997		M6 PLAIN WASHER	6	6
13	C15133		TERMINAL BLOCK	10	10
14	C10129		M3 x 20 BTN HD SCREW	2	2
15	C10747		M3 S/C SPRING WASHER	2	2
16	C08028		M3 PLAIN WASHER	2	2
17	C05298		M3 FULL NUT	2	2

11
10
9
8
7
6
5
4
3
2
1

FRANCIS SEARCHLIGHTS LIMITED . UNION ROAD . BOLTON . BL2 2HU

Send Coasting: To ISO 8062 C10 [MATERIAL]
Die Coasting: To ISO 8062 C18
Hole centres & posns: ±

TOLERANCES
General: ±
Angular: ±

SCALE 1:2
ALL DIMENSIONS IN MILLIMETRES

FINISH

DESCRIPTION

ITEM PART No. DRG No. DESCRIPTION QTY

1	C23639	C23639	CHASSIS PLATE S/ASSY	1	1
2	C23640	C23640	ENCLOSURE DRILLING	1	1
3	C23641	C23641	ENCLOSURE DRILLING	1	1
4	C27064	C24143	DIN RAIL	1	1
5	C15450		M25 GLAND	1	1
6	C24231	C24231	ENCLOSURE DRILLING	1	1
7	C10158		M20 GLAND	2	3
8	C20537		BALLAST	1	1
9	C26986		10AMP MCB	1	1
10	C10213		M6 x 12 PAN HD SCREW	6	6
11	C10554		M6 S/C SPRING WASHER	6	6
12	C06997		M6 PLAIN WASHER	6	6
13	C15133		TERMINAL BLOCK	10	10
14	C10129		M3 x 20 BTN HD SCREW	2	2
15	C10747		M3 S/C SPRING WASHER	2	2
16	C08028		M3 PLAIN WASHER	2	2
17	C05298		M3 FULL NUT	2	2

11
10
9
8
7
6
5
4
3
2
1

FRANCIS SEARCHLIGHTS LIMITED . UNION ROAD . BOLTON . BL2 2HU

Send Coasting: To ISO 8062 C10 [MATERIAL]
Die Coasting: To ISO 8062 C18
Hole centres & posns: ±

TOLERANCES
General: ±
Angular: ±

SCALE 1:2
ALL DIMENSIONS IN MILLIMETRES

FINISH

DESCRIPTION

ITEM PART No. DRG No. DESCRIPTION QTY

1	C23639	C23639	CHASSIS PLATE S/ASSY	1	1
2	C23640	C23640	ENCLOSURE DRILLING	1	1
3	C23641	C23641	ENCLOSURE DRILLING	1	1
4	C27064	C24143	DIN RAIL	1	1
5	C15450		M25 GLAND	1	1
6	C24231	C24231	ENCLOSURE DRILLING	1	1
7	C10158		M20 GLAND	2	3
8	C20537		BALLAST	1	1
9	C26986		10AMP MCB	1	1
10	C10213		M6 x 12 PAN HD SCREW	6	6
11	C10554		M6 S/C SPRING WASHER	6	6
12	C06997		M6 PLAIN WASHER	6	6
13	C15133		TERMINAL BLOCK	10	10
14	C10129		M3 x 20 BTN HD SCREW	2	2
15	C10747		M3 S/C SPRING WASHER	2	2
16	C08028		M3 PLAIN WASHER	2	2
17	C05298		M3 FULL NUT	2	2

11
10
9
8
7
6
5
4
3
2
1

FRANCIS SEARCHLIGHTS LIMITED . UNION ROAD . BOLTON . BL2 2HU

Send Coasting: To ISO 8062 C10 [MATERIAL]
Die Coasting: To ISO 8062 C18
Hole centres & posns: ±

TOLERANCES
General: ±
Angular: ±

SCALE 1:2
ALL DIMENSIONS IN MILLIMETRES

FINISH

DESCRIPTION

ITEM PART No. DRG No. DESCRIPTION QTY

1	C23639	C23639	CHASSIS PLATE S/ASSY	1	1
2	C23640	C23640	ENCLOSURE DRILLING	1	1
3	C23641	C23641	ENCLOSURE DRILLING	1	1
4	C27064	C24143	DIN RAIL	1	1
5	C15450		M25 GLAND	1	1
6	C24231	C24231	ENCLOSURE DRILLING	1	1
7	C10158		M20 GLAND	2	3
8	C20537		BALLAST	1	1
9	C26986		10AMP MCB	1	1
10	C10213		M6 x 12 PAN HD SCREW	6	6
11	C10554		M6 S/C SPRING WASHER	6	6
12	C06997		M6 PLAIN WASHER	6	6
13	C15133		TERMINAL BLOCK	10	10
14	C10129		M3 x 20 BTN HD SCREW	2	2
15	C10747		M3 S/C SPRING WASHER	2	2
16	C08028		M3 PLAIN WASHER	2	2
17	C05298		M3 FULL NUT	2	2

11
10
9
8
7
6
5
4
3
2
1

FRANCIS SEARCHLIGHTS LIMITED . UNION ROAD . BOLTON . BL2 2HU

Send Coasting: To ISO 8062 C10 [MATERIAL]
Die Coasting: To ISO 8062 C18
Hole centres & posns: ±

TOLERANCES
General: ±
Angular: ±

SCALE 1:2
ALL DIMENSIONS IN MILLIMETRES

FINISH

DESCRIPTION

ITEM PART No. DRG No. DESCRIPTION QTY

1	C23639	C23639	CHASSIS PLATE S/ASSY	1	1
2	C23640	C23640	ENCLOSURE DRILLING	1	1
3	C23641	C23641	ENCLOSURE DRILLING	1	1

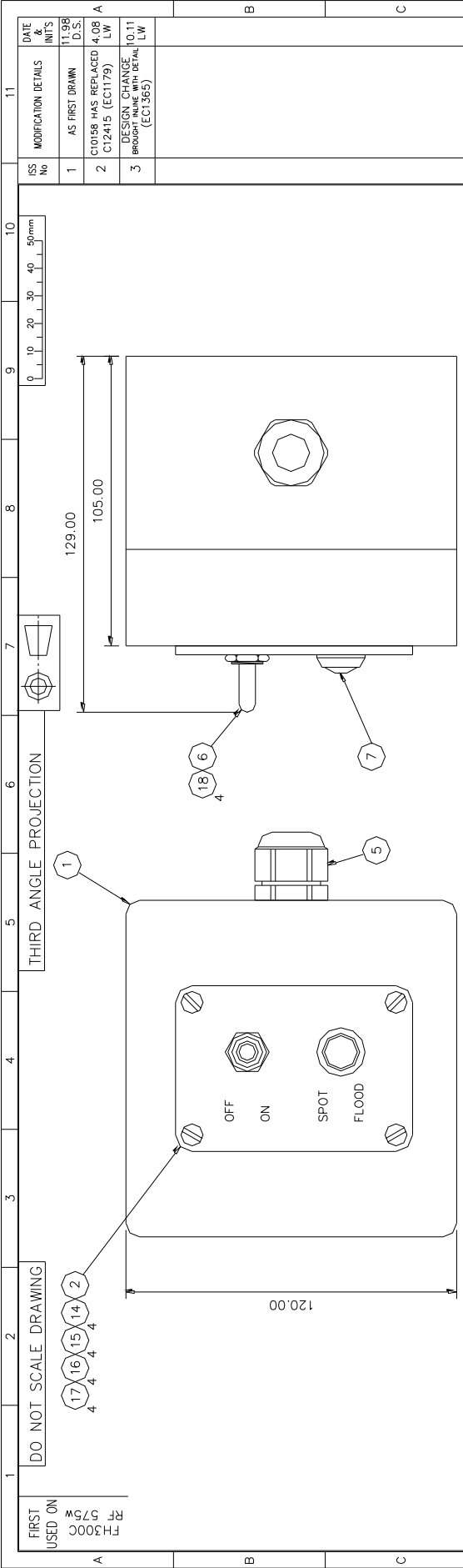

ITEM	PART No.	DRG No.	DESCRIPTION	QTY
1	C20291	C20291	ENCLOSURE DRILLING	1
2	C15884	X4186	CONTROL PANEL	1
3	C20289	C20289	DIN RAIL	1
4	C20288	C20288	MOUNTING PLATE	1
5	C10158		GLAND	1
6	C15792		SELECTOR SWITCH	1
7	C24135		PUSH BUTTON	1
8	C16488		TRANSFORMER	1
9	C14400		TERMINAL	6
10	C14139		END COVER	1
11	C09167		EARTH TERMINAL	1
12	C16854		DIODE	1
13	C10204		SCREW M4 x 8 PN HD	4
14	C06529		SCREW M4 x 10 CSK HD	4
15	C08793		WASHER M4 S/C SPRING	8
16	C04376		WASHER M4 PLAIN	8
17	C06266		NUT M4 FULL	8
18	C15828		RED SHROUDED RECEPTACLE	4

ISS No	MODIFICATION DETAILS	DATE IN INITS
1	AS FIRST DRAWN	11.08 D.S.
2	C10158 HAS REPLACED C12415 (EC1179)	4.08 LW
3	DESIGN CHANGE BROUGHT INLINE WITH DETAIL (EC1365)	10.11 LW

STANDARD PRACTICE
 Debur all cut/machined edges
 Break corners R0.25(Max) U.O.S.

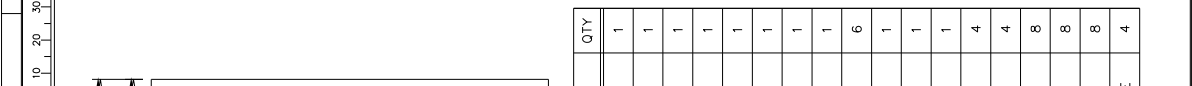

FRANCIS SEARCHLIGHTS LIMITED . UNION ROAD . BOLTON . BL2 2HU	© 1998	A2	CONT ON SHEET
DRAWN	D.S.	DATE	11.98
CHECKED	SCALE	1:1	TOLERANCES
ALL DIMENSIONS IN MILLIMETRES		General: ±	Angular: ±
Hole centres & posns: ±		Sand Casting: To ISO 8062 CT10	
Die Casting: To ISO 8062 CT18		MATERIAL	
FINISH		DESCRIPTION	
240v RF 575w CONTROL UNIT		PART No./DRG No.	
C20292		SHT	
1		1	

10 – Spare Parts List

The following spare parts can be ordered directly from the manufacturer:

Part Number	Description
D15764	575w Metal Halide Lamp
C10870-00	Lampholder – G22
C08890-00	Front glass
C20567-00	Front / rear bezel gasket
C08884-00	Reflector
C16880-00	Ignitor
C22268-01	Breather Assembly
C09888-01	Focus Wheel Assembly
C14501-00	Focus Wheel Seal
C16893-00	Focus Grommet
C10168-00	Base 'O' Ring (Deck & Cabin))
C10169-00	Spigot 'O' Ring (Cabin & Cabin Pedestal)
C10170-00	Pedestal 'O' Ring (Deck Pedestal & Cabin Pedestal)
C22072-00	Push Rod Seal Washer (Cabin & Cabin Pedestal)
C21967-00	Bellows Bottom Bush 'O' Ring (Cabin & Cabin Pedestal)
C20281-00	Bellows (Cabin & Cabin Pedestal)
C11025-01	Lock Wheel Assembly (Deck & Deck Pedestal)
C11026-01	Lock Wheel Assembly (Cabin)
C15792-00	Selector Switch (Remote Focus)
C24135-00	Push Button (Remote Focus)
C16488-00	Transformer (Remote Focus)
C20537-00	Ballast
C26986-00	MCB

In order to prolong the life and performance of your product, we recommend that you only specify Francis Searchlights spare parts. This will ensure that any warranties on your equipment will not be invalidated.

When ordering spare parts please contact the Sales Department at Francis Searchlights Limited. Please quote searchlight model and serial number at all times. This will enable a fast response to your spares' requirements.