

LITE
380mm

Francis
SEARCHLIGHTS

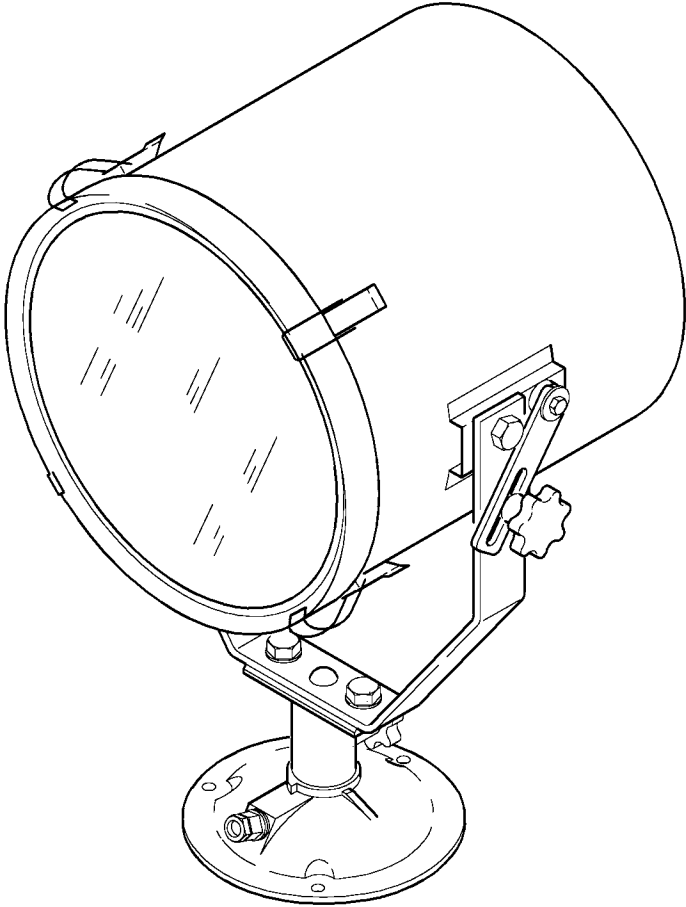

**Lite 380 Searchlight
User Information**

Contents

	<i>Page</i>
USER INFORMATION FOR LITE 380 SEARCHLIGHT	1
INTRODUCTION.....	1
SAFETY PRECAUTIONS.....	1
UNPACKING INSTRUCTIONS.....	2
INSTALLATION INSTRUCTIONS.....	2
<i>Safety Precautions</i>	2
<i>Preparing the Mounting Position</i>	3
<i>Mounting the Searchlight</i>	3/4
<i>Power Supply Requirements</i>	5
OPERATING INSTRUCTIONS.....	6
<i>Setting to Work</i>	6
<i>Testing</i>	7
FAULT FINDING.....	7
<i>Fault</i>	7
<i>Remedy</i>	7
MAINTENANCE AND SERVICING REQUIREMENTS.....	8
SPARE PARTS LISTS	
BARREL ASSEMBLY.....	9
LAMPHOLDER H.V. GX9.5.....	10
LAMPHOLDER L.V. GX6.35.....	11
DECK MOUNT.....	12
PEDESTAL ASSEMBLY.....	13
CABIN TRAINER MOUNT CONVERSION.....	14
SEAL KITS.....	15
SPARE PARTS ORDERING.....	16
PARTS DISPOSAL.....	16
SALES AND SERVICE.....	16
GUARANTEE.....	16

User Information for Lite 380 Searchlight

It is imperative that this manual is read carefully before installing or using your equipment. For your future reference this manual should be kept in a safe place.

Introduction

Thank you for specifying a product from the Francis Searchlights Ltd range. All Francis products are designed to give complete customer satisfaction and are manufactured to the highest engineering standards in order to ensure optimum performance and service life.

The Lite Series Searchlights combine design features proven over many years of service in the most hazardous conditions in both marine and land installations.

In order to prolong the life and performance of your product, we recommend that you only specify Francis Searchlights spare parts. This will also ensure that any warranties on your equipment will not be invalidated. Information on spares ordering and parts is provided in this manual.

Should you ever need to contact Francis Searchlights Ltd. regarding your equipment, please quote the Product Serial Number at all times. Please complete the following boxes for your future reference purposes.

Product Number	Serial Number

Safety Precautions

The following instructions must be adhered to in order to ensure a safe working environment and the safety of the user.

Note: *When manoeuvring the searchlight into its fixing position, suitable lifting points must be chosen in order to prevent damage to the equipment or personal injury.*

- Prevent rain, snow, condensation and water droplets from contacting the lamp as this may cause bulb failure, and possible shattering;
- Quartz halogen lamps run with a high internal pressure in excess of atmospheric. Whilst the construction is inherently strong, there is a slight risk of the lamp shattering;
- Never look directly into an illuminated searchlight as this may cause severe damage to eyesight. If it is necessary to inspect a lamp whilst in operation, always wear suitable protective goggles;

- Should it be necessary to examine the lamp with the front bezel removed, always use a protective shield to ensure a safe working environment;
- Never attempt to clean the lamp when in use;
- Searchlights get hot. Never touch the unit when lit and always allow at least ten minutes for cooling down after turning off;
- Ensure the lamp has cooled sufficiently before removal. During the cooling down period avoid mechanical or thermal shock to the lamp as this may cause shattering;
- If undue force appears necessary to remove the lamp, the equipment should be inspected by a competent person, or contact the manufacturer;
- When breaking a lamp for disposal, care must be taken to ensure that the fragments are safely contained. Precautions must be taken against flying glass and other fragments. This operation should be performed outdoors or in a well ventilated area. In ALL cases reference should be made to the lamp manufacturers instructions packed with the lamp;
- Due to the vast range of lamps available, it may appear possible that more powerful lamps can be used in the equipment for which it was designed. Even when the unit will physically accept a higher wattage lamp, this substitution is not recommended as it could be dangerous.

Unpacking Instructions

Care should be taken when unpacking the searchlight, so as not to cause damage to the equipment or cause personal injury. A visual inspection of the equipment should be conducted to check for damage during transit or damaged lamps.

Enclosed in the packing is the flange sealing gasket. This should be retained for installation purposes.

For Cabin, Deck Pedestal and Cabin Pedestal models, conversion kits are supplied and should be retained for installation purposes.

Installation Instructions

The following instructions should be read and fully understood prior to installing the equipment to ensure correct procedures are followed and all safety precautions are observed.

Note: *If the equipment has been in storage for a considerable time, it is advisable to conduct a routine maintenance check on all parts before installation.*

Safety Precautions

This equipment should not be connected to an electrical supply before being installed. Installation procedures should be adhered to in order to ensure a safe working environment and reduce the risk of damage or injury.

Preparing the Mounting Position

Using the template provided mark out and drill the fixing holes through the deck or cabin roof. In the case of cabin control models, a centre hole is also required to allow the mechanism to pass through.

Mounting the Searchlight

For Deck Models:

Fit the 'O' ring in position and bolt the searchlight base securely down. On an uneven surface it is necessary to use a suitable sealant, such as silicone, in order to ensure a weather proofed joint.

For Cabin/Cabin Pedestal Models:



Remove the Base Lockwheel and the M6 Hexagon Screw.



Now Lift the Searchlight Head and Crutch free of the Base.



Insert the brass Crutch Base Sleeve into the Crutch Base and align the spot face with the top M6

hole. (Do not fasten the Crutch Base Sleeve in position yet).



Re-mount the Searchlight Head onto its Base and fasten in position using the M8 x 10 Hexagon Screw in

the bottom fixing.



Now remove the following items, as these are only required on Deck Models. Barrel Lockwheel, Elevation Link and fixings.



When installing the Underdeck Mechanism first separate the following items. U-Piece Assembly, M8 Nyloc Nut, M8 Plain Washer, M12 Plain Washer, Rubber Bellows, Bellows Top Bush and the Push Rod Top Bush.

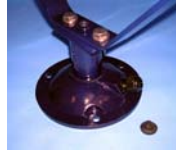

Remove the Blanking Plug from the Bellows Bottom Bush.



Insert the Underdeck through the centre hole, rotating until the Push Rod Screw engages in the Crutch Base Sleeve.

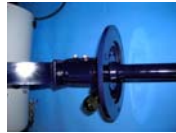

When fully located fix in position using the top M6 Hexagon Screw. (Do not overtighten).



Fasten the Underdeck Mechanism using the 3 off M6 x 16 Pan Head Screws and Spring Washers.



Re-Fit the following items.

Push Rod Top Bush.

Bellows Top Bush.



Bellows.

M12 Plain Washer.

U-Piece Assembly.

M8 Plain Washer.

M8 Nyloc Nut.



U-Piece fixings.



Fix the U-Piece Assembly using the above fixings make sure there is a Plain Washer both sides of the U-Piece Bush.

both sides of the U-Piece Bush.



Completed. Make sure the searchlight pans and tilts correctly.

For Pedestal Models:

Mark out and drill through cabin roof using the template provided.

Remove the cable gland in the base and replace with the blanking plug supplied.

Secure the pedestal to the deck using appropriate fixings and then mount the searchlight to the pedestal and secure using the fixings provided. A drilled hole is also required in the deck to allow for the connection to an electrical supply. The searchlight is supplied with 3 metres of supply cable so that the installer can choose a suitable connection point.

Power Supply Requirements

For safety purposes, only competent personnel should perform the electrical installation. All equipment should be installed to current Electrical Regulations and Standards.

In order to obtain maximum light output from the searchlight, it is essential that the full operating voltage of the lamp fitted is applied to the lampholder contacts.

Method of Electrical Connection

Disconnect the supply before working on the electrical system.

The searchlight must be connected to a fused electrical supply, using suitably sized cable.

If the searchlight is positioned a considerable distance from the supply, provision must be made in the cable size in order to overcome the voltage drop. The following table should be used for indication only.

24v	150w	250w
<u>Cable Size</u>	<u>Max</u>	<u>Max</u>
1.5mm ²	5 M	3 M
2.5mm ²	8 M	5 M
4mm ²	13 M	8 M
6mm ²	20 M	12 M
10mm ²	34 M	20 M

115v	1000w
<u>Cable Size</u>	<u>Max</u>
1.5mm ²	17 M
2.5mm ²	28 M
4mm ²	44 M
6mm ²	68 M
10mm ²	115 M

	230v	650w	1000w
<u>Cable Size</u>	<u>Max</u>	<u>Max</u>	<u>Max</u>
1.5mm ²	105 M	68 M	
2.5mm ²	171 M	111 M	
4mm ²	271 M	176 M	
6mm ²	422 M	275 M	
10mm ²	707 M	460 M	

Whenever possible cable terminations should be made below deck and with approved terminal devices.

If a spare auxiliary fuse or circuit breaker is not available, one of the correct type and rating should be fitted and connected to a positive supply. It is advisable to locate a bus bar or main connection and avoid any direct connection to the supply.

When wiring the negative supply, the direct connection to a battery or supply, or metal hull/object, should be avoided. It is advisable to use a suitable commoning block or connection.

For ease of use a single pole switch, of the appropriate rating, should be fitted in a convenient location. All cable lengths should be kept to a minimum.

Operating Instructions

This equipment is designed for use out of doors, in free air.

Never place anything on, or cover, the searchlight when in operation as this may present a hazard.

The searchlight can be positioned using the elevation and baseplate lockwheels. When in the desired position the lockwheels must be securely fastened to prevent damage.

The beam of the searchlight can be adjusted to give a variety of 'spreads'. Using the focussing handle situated underneath the barrel head. The lampholder can be moved into the desired position, towards the front for spot or the rear for flood.

The searchlight is fitted with a breather unit Assembly. This ensures a steady airflow in order to prevent any vacuum forming within the barrel.

Note: *This product should not be used for any purpose other than for which it was designed. Any modifications to the product should not be undertaken before consulting the manufacturer or agent.*

Setting to Work

Safe service in use necessitates the strict observance of the following precautions.

Any article fabricated from quartz or glass is inherently fragile and care

should therefore be taken at all times when handling lamps.

Eye protection must be worn when handling lamps that have been removed from their packaging materials. The protective sleeve should not be removed from the lamp for safety reasons as there is a remote possibility of the lamp shattering violently, especially if it is submitted to mechanical shock or vibration.

Quartz lamps should not become contaminated with oils, grease or come into contact with skin.

When fitting the lamp:

- Always isolate the equipment from the supply before inserting a lamp;
- Ensure the circuit is suitably fused;
- Ensure that the lamp is of the recommended type and rating;
- Check the lampholder is in good condition. If the contacts show any sign of corrosion the lampholder should be replaced;
- Check that the lampholder is in a good dry condition. Never allow water to collect in the lamp fitting or come into contact with the lamp.

To fit the lamp:

- Remove the front bezel assembly by operating the safety catch and lifting the latch body;
- Cut open one end of the protective sleeve surrounding the lamp;
- Using the sleeve to prevent the fingers coming into contact with

the lamp, position the two pins above the holes in the lampholder;

- Gently push the lamp into the lampholder and discard the protective sleeve;
- Position the front bezel assembly centrally onto the searchlight and fasten the claw latches, ensuring the safety catch is engaged.

Therefore:

$$\text{Wattage} = 240 \times 4 = 960 \text{ watts.}$$

Testing

Upon correct installation and connection to an electrical supply, the equipment can be tested in order to ensure it's correct performance. This work must be carried out by a competent person with some knowledge of electrical equipment.

Equipment required:

Multi-meter with leads;
Ammeter.

Using the equation $P=VI$ the approximate power output of the equipment can be calculated in the following way:

- Using the multi-meter take a voltage reading;
- Using the Ammeter, take an amps reading from the live cable to the lamp;
- Multiply these values together to give an approximate wattage.

For Example:

Using a 240v 1000w Tungsten Halogen lamp,

Voltage reading : 240v

Amps reading: 4 amps

Fault Finding

If a fault occurs the following procedures should be adopted. Any work to be carried out should be conducted by a competent person. A multimeter should be used for fault finding purposes.

Fault

Lamp Fails to light

Causes

- 1) Power not supplied
- 2) Fuse blown
- 3) Failed lamp

Remedy

- 1) Check voltage at supply/battery. If necessary recharge battery. If supply is not present fault is at customer supply. If power is present, see remedy 2.
- 2) Check fuse for visual failure. If none noticeable check fuse for continuity. If fuse found to be faulty, replace with new part. If found to be working correctly see remedy 3.
- 3) Firstly, check supply at lampholder connecting block (within searchlight barrel). If supply present, disconnect unit from power supply before removing lamp. If noticeable damage to filament is present, the lamp will have failed. The lamp can also be checked using a multimeter for continuity of the filament. Replace new lamp following all precautions mentioned previously and lamp manufacturers instructions.

Maintenance and Servicing Requirements

In order to prolong the service life and performance of your searchlight, the following maintenance guidelines are recommended:

- Maintenance checks should be conducted before every voyage or every three months;
- Before checking, disconnect the equipment from the supply;
- Visually check the condition of the equipment;
- Any major or minor structural damage or defect should be rectified immediately;
- After inspection it may be necessary to clean the inside of the searchlight. The following procedure should be adhered to:
 - Remove the front bezel;
 - Clean the front glass inside and out using a proprietary glass cleaner or metal polish;
 - Clean the reflector, if required;
 - Ensure the lampholder is free from corrosion or damage;
 - Check the earthing point for conductivity;
 - Check lampholder assembly for signs of damage or wear.
 - Upon completion of these checks, the searchlight should be tested for full working order (approximately 15 minutes);

- Every six months the external movement mechanisms, i.e. lockwheels, elevation and pan mechanisms, may be lightly lubricated.

Note: *It is advisable to check all seals and gaskets for degradation. If replacement is necessary the kit numbers are quoted in the back of the spares lists.*

Spare Parts Lists

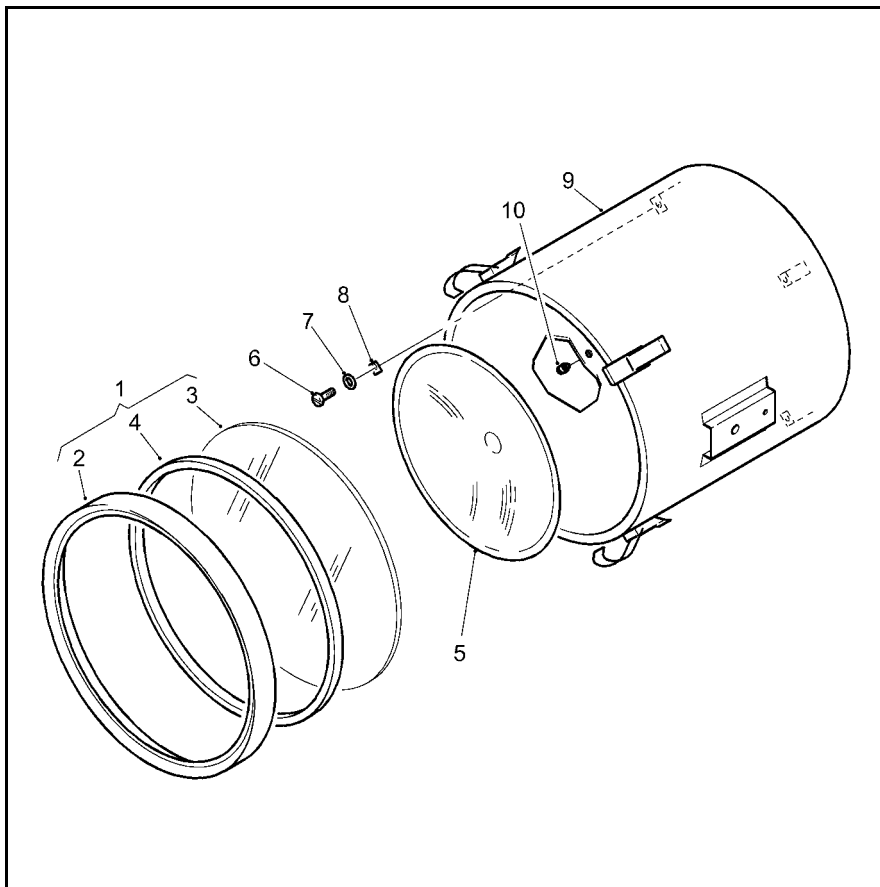

Item No.	Description	Part No.	No. Off
1	Front Bezel Assembly	C22307-01	1
2	Front Bezel	C22002-79	1
3	Front Glass	C22305-00	1
4	Front Glass Gasket	C22011-00	1
5	Reflector	C22310-00	1
6	Screw M4 x 12 Pan Head	C10205-00	4
7	Washer M4 Spring	C08793-00	4
8	Mirror Clip	C20858-01	4
9	Barrel Sub-Assembly	C22297-01	1
10	Breather Assy	C22268-01	1

Lampholder H.V. GX9.5 - C22303-01

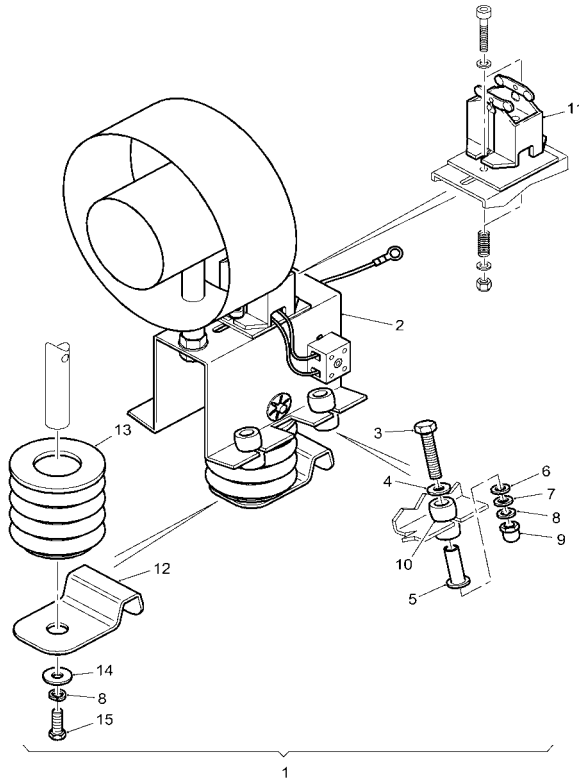

Item No.	Description	Part No.	No. Off
1	Lite 380 L/H Conversion Kit GX9.5	C22318-01	
2	Lampholder Assembly	C22303-01	1
3	Screw M4 x 30 Hex. Head	C16764-00	4
4	A.V. Washer	C16763-55	4
5	A.V. Bush	C16762-55	4
6	Washer M4 Nylon	C15272-00	4
7	Washer M4 Plain	C04376-00	4
8	Washer M4 Spring	C08793-00	5
9	Nut M4 Domenut	C11183-00	4
10	A.V. Mount	C16761-00	4
11	Lampholder	C03022-00	1
12	Focus Handle	C22561-01	1
13	Focus Bellows	C22550-00	1
14	Washer Ø12.0 O/D Plain	C20637-00	1
15	Screw M4 x 10 Hex. Head	C14533-00	1

Lampholder L.V. GX6.35 - C22332-01

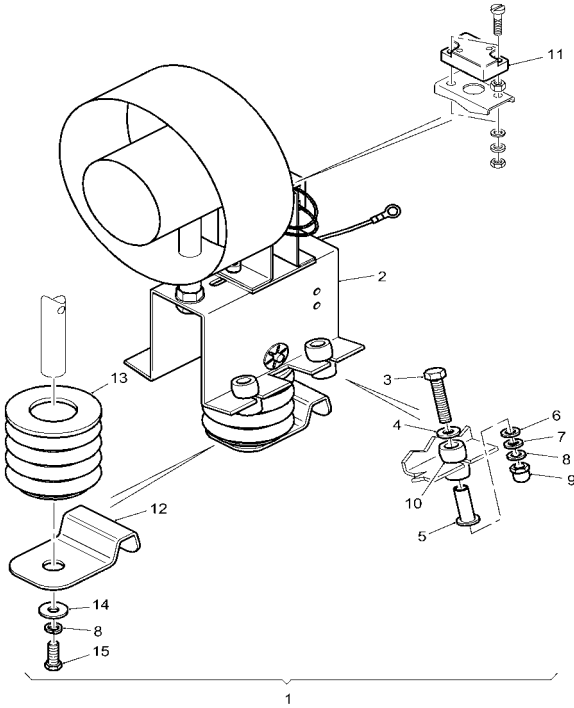

Item No.	Description	Part No.	No. Off
1	Lite 380 L/H Conversion Kit GX6.35	C22308-01	
2	Lampholder Assembly	C22332-01	1
3	Screw M4 x 30 Hex. Head	C16764-00	4
4	A.V. Washer	C16763-55	4
5	A.V. Bush	C16762-55	4
6	Washer M4 Nylon	C15272-00	4
7	Washer M4 Plain	C04376-00	4
8	Washer M4 Spring	C08793-00	5
9	Nut M4 Domenut	C11183-00	4
10	A.V. Mount	C16761-00	4
11	Lampholder	C16878-00	1
12	Focus Handle	C22561-01	1
13	Focus Bellows	C22550-00	1
14	Washer Ø12.0 O/D Plain	C20637-00	1
15	Screw M4 x 10 Hex. Head	C14533-00	1

Deck Mount - C22311-01

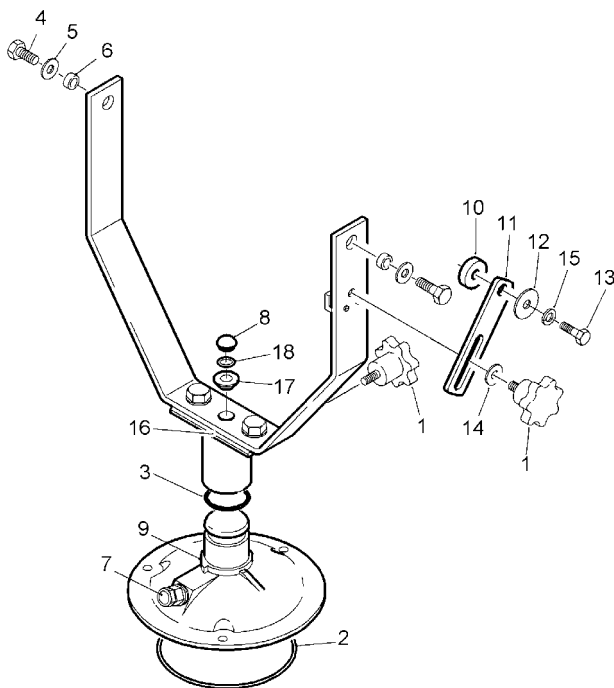

Item No.	Description	Part No.	No. Off
1	Lockwheel Assembly	C11025-01	2
2	`O' Ring Seal Base	C10168-00	1
3	`O' Ring Seal Spigot	C10169-00	1
4	Screw M12 x 20 Hex. Head	C08369-00	2
5	Washer M12 Plain	C08370-00	2
6	Trunnion Spacer	C22264-01	2
7	Cable Gland	C10158-00	1
8	Blanking Plug	C20684-00	1
9	Floating Stop	C08929-79	1
10	Elevation Bush	C20595-79	1
11	Elevation Link	C20594-79	1
12	Elevation Washer	C20596-79	1
13	Screw M6 x 25 Hex. Head	C09580-00	1
14	Washer M8 Plain	C06999-00	1
15	Washer M6 Spring	C10554-00	1
16	Push Rod Seal Washer	C22072-00	1
17	Bellows Bottom Bush	C20269-01	1
18	`O' Ring	C21967-00	1

Pedestal Assembly - C20636-79

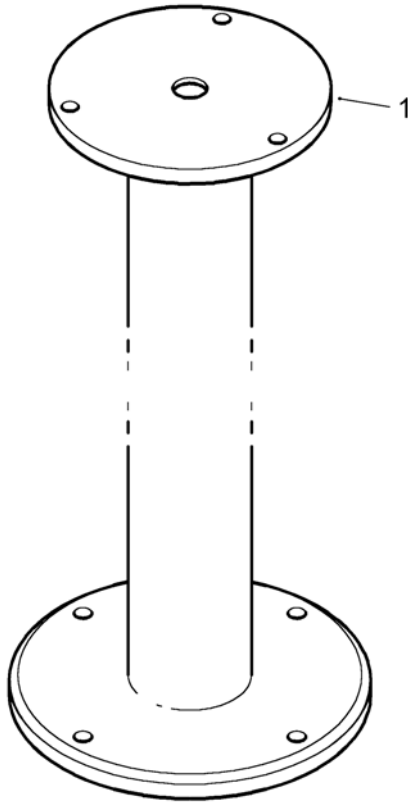

Item No.	Description	Part No.	No. Off
1	Pedestal Assembly	C20636-79	1

Cabin Trainer Mount Conversion - C22314-01
Cabin Pedestal Trainer Mount Conversion - C22317-01

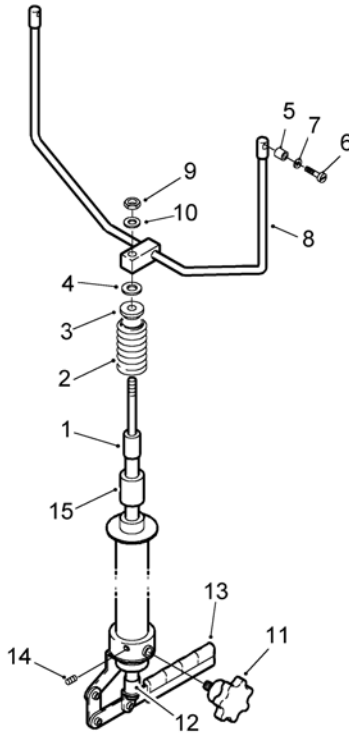

Item No.	Description	Part No.	No. Off
1	Push Rod Top Bush	C20586-01	1
2	Bellows	C20281-00	1
3	Bellows Top Bush	C20270-01	1
4	Washer M12 Plain	C08370-00	1
5	U-Piece Bush	C08932-01	2
6	Screw M6 x 20 Pan Head	C10174-00	2
7	Washer M6 Plain	C06997-00	2
8	U-Piece Assembly	C22315-79	1
9	Nut M8 Nyloc	C12354-00	1
10	Washer M8 Plain	C06999-00	1
11	Lockwheel Assembly	C20745-01	1
12	Push Rod Bottom Bush	C20587-01	1
13	Handle	C20549-00	1
14	Grubscrew	C06401-00	3
15	Crutch Base Sleeve	C20732-01	1

Seal Kits

Description	Part No.
Deck Gasket Seal Kit	C22705-01
Cabin Gasket Seal Kit	C22706-01
Deck Pedestal Gasket Seal Kit	C22707-01
Cabin Pedestal Gasket Seal Kit	C22708-01

Spare Parts Ordering

In order to prolong the life and performance of your searchlight it is recommended that only Francis Searchlights Ltd. spare parts are specified. Reference should be made to the relevant spares section in this manual. The part number should be quoted at all times so that a price and delivery time can be supplied.

Spare parts or accessories can be obtained from your distributor/agent or directly from the manufacturer.

Parts Disposal

It is essential that all parts are disposed of correctly and safely to ensure no risk to other personnel. When disposing of lamps the procedures outlined in this manual and the lamp manufacturers leaflet must be adhered to.

The reworking or modification of parts should not be undertaken before consulting the manufacturer or agent.

Sales and Service

For sales and service please contact your agent/distributor or contact the manufacturer direct at:

Francis Searchlights Limited
Union Road
Bolton
BL2 2HJ

England

Tel: +44 (0) 1204 558960

Fax: +44 (0) 1204 558979

E-mail: sales@francis.co.uk

<http://www.francis.co.uk>

Guarantee

This product is covered with a 12 month warranty. Any claim whilst under warranty should be addressed to the Quality Manager at Francis Searchlights Ltd.

Agent/Distributor Stamp

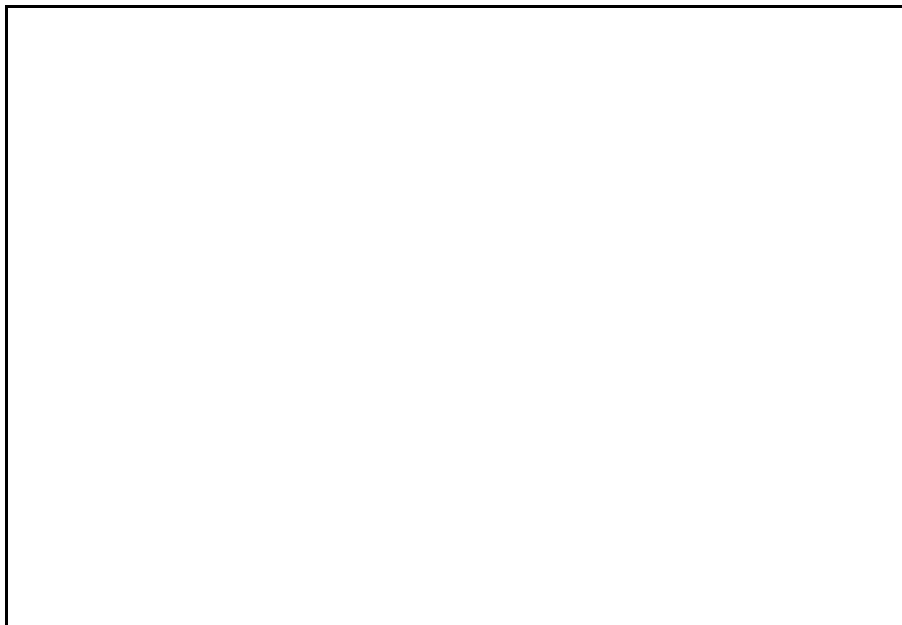

The manufacturer reserves the right to change the information contained within this booklet without prior notice.



FRANCIS SEARCHLIGHTS LTD
UNION ROAD, BOLTON, BL2 2HJ, ENGLAND
Tel +44 (0) 1204 558960 Fax: +44 (0) 1204 558979
<http://www.francis.co.uk>

Cert No. 2094
BS5750 Part 1
(ISO 9001)

