



**FH300RC Explorer**  
**Issue 3, Metal Halide**  
**575 w. Remote Control**

**APPLICATION**

*The FRANCIS FH EXPLORER is part of the premium Range of Remote Control searchlights & has been designed with the precise aim of bringing to the market, the ultimate searchlight able to guarantee high performance, strength and affordability.*

The **Premium** FH300RC Explorer has been carefully developed to withstand the extraordinary conditions while in use in the harshest of environment, such as Coast Guard patrol. The heavy duty gearbox is strong, powerful and able to operate in the rough seas and high strength winds as found in coastal areas such as Canada and Scandinavia. This range now also has the added benefit of a heater fitted to the gearbox as standard, allowing an operation temperature of up to -50 °c.

**PART NUMBER**

Type	Supply	L/holder	Part Number
FH300 RC	240v	G22	A2546

**SPECIFICATION**

- Quality construction using brass and stainless steel
- Stove enamel painted finish.
- Parabolic glass reflector.
- Instant lamp re-strike. No cooling down time required.
- Remote focus fitted as standard.
- Joystick control panel supplied.
- Toughened front glass.
- Sealing to IP66 Gearbox/Control gear – IP 56 Searchlight.
- Remote elevation control ±25°.
- Remote pan rotation 365°.
- Rotation speed 20°/sec.
- Elevation speed 5°/sec.
- Operational temperature -50° C.
- Heater standard in gearbox and optional in barrel.
- Luminous flux 49000.
- Colour temperature 6000 K.

**Performance Data** \* Inclusive angle

Volts	Lamp Life	Range (m)	PBCP x1000	*Div	Watts	Lamp Cap	Lamp Part No.
240v	1000hrs	3685	13600	2.5	575	G22	D15764

**Francis Searchlights Limited**  
 Union Road, Bolton, BL2 2HJ, UK  
 Tel 44 (0) 1204 558960 Fax 44 (0) 1204 558979  
 Email sales@francis.co.uk Web site www.francis.co.uk

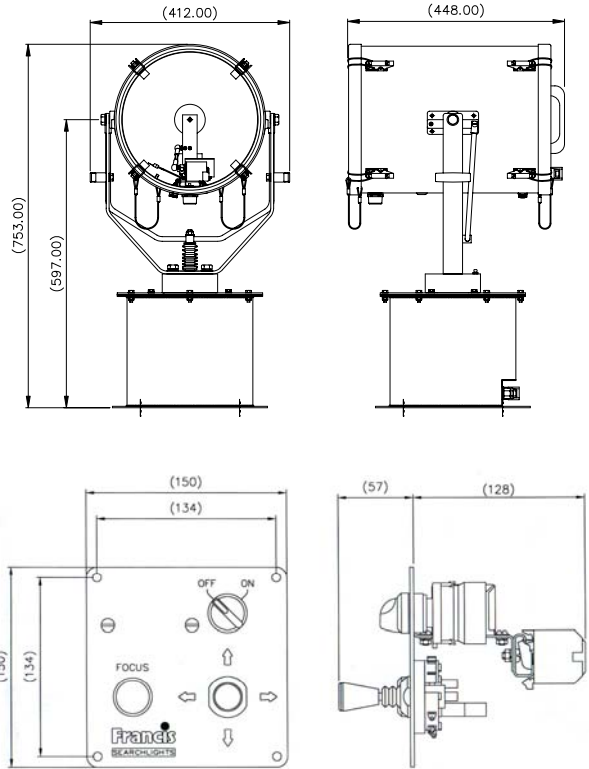

All Dimension in Millimetres

**Base fixings**

4 holes Ø12.5 on a 290 PCD

A pedestal mounting option is available upon request.

**Weights**

FH300RC 30.20Kg  
 Control gear (280 x 190 x 182cm) - 3.5Kg

For more information contact: