



**FX230 Issue 4
Xenon 150w
Manual Control**

APPLICATION

The FRANCIS FX Premium range of searchlights incorporate the design features required to successfully operate searchlights in the most demanding product operating environments on land and sea. With the "colour temperature" of the Xenon lamp being equal to that of "sunlight" the searchlight is ideal for spotting dangers to navigation in the Polar regions, such as low-lying icebergs. The FX230 can be fitted with an optional infra-red facility which is IDEAL for covert use during security operations. Other applications include search and rescue work as well as use onboard fast patrol craft.

DESPATCH NUMBERS			
Type	Supply	Weight	Part Number
FX230 Deck	10-28v	18.0 Kg	A2432
FX230 Cabin	10-28v	21.5 Kg	A2433

SPECIFICATION

- Immediate full lamp brilliance from switch on.
- Instant re-strike. No "cooling" down time required.
- Toughened front glass.
- Economical 1200 hour lamp life. Lamp Part No. D8151
- Constructed from Marine grade materials and fixings.
- Stove enamel paint finish.
- Parabolic form electro-formed nickel, bright rhodium coated reflector.
- Full 450° rotation.
- Vertical movement ±45° (Deck) -20° to +40° (Cabin)
- Operation temperature -50°C.
- Adjustable lamp focus, 1.5° spot to 10° flood.
- Remote focus fitted as standard.
- Supplied with control panel (ON/OFF & FOCUS SWITCH).
- Special "B" dimensions available on request.
- Sealing to IP56.

Type	Watts	Range @ 1Lux	P.B.C.P.	Divergence
FX230	150w	2341 metres	5,479,861	1.5

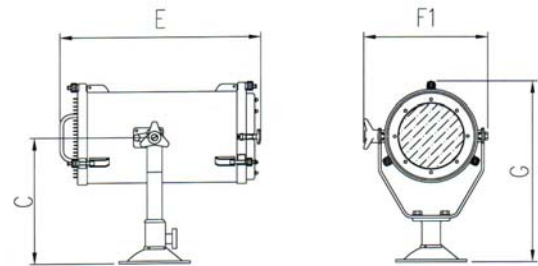

Deck

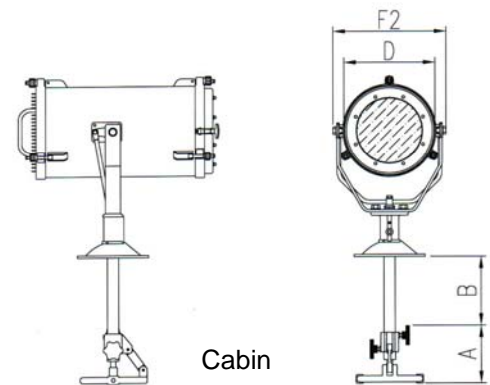

Cabin

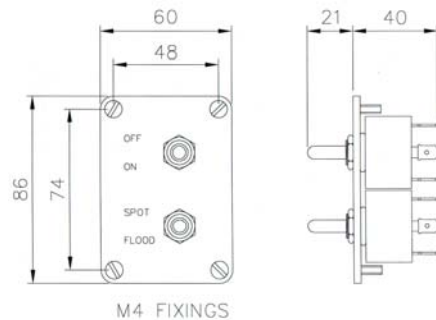

All dimensions in Millimeters
Base fixings
 3 holes Ø11.0 on a 154.0 PCD
 Cabin control hole Ø40.0

Dimensions							
A	B	C	D	E	F1	F2	G
150	185	323	230	497	316	288	460

For more information contact:

Francis Searchlights Limited
 Union Road, Bolton, BL2 2HJ, UK
 Tel 44 (0) 1204 558960 Fax 44 (0) 1204 558979
 Email sales@francis.co.uk Web site www.francis.co.uk