



**FX560RC Issue 4
Xenon 2 Kw Remote
Control, Variable Speed**

APPLICATION

The FRANCIS FX Premium range of variable speed Remote Controlled Searchlights incorporate the design features required to successfully operate searchlights in the most demanding product operating environments on land and sea.

Francis Searchlights have redesigned and improved the remote controlled Xenon Searchlight still further by adding full variable speed as a standard option at no extra cost.

With the "colour temperature" of the Xenon lamp being equal to that of "sunlight" the searchlight is ideal for spotting dangers to navigation in the Polar Regions, such as low-lying icebergs. Other potential hazards, such as debris and small craft, are easily spotted at long range allowing sufficient time for action to be taken.

SPECIFICATION

- Immediate full lamp brilliance from switch on.
- Instant re-strike. No "cooling" down time required.
- Toughened front glass.
- Parabolic glass reflector.
- Economical 3000 hour lamp life. Lamp Part no. D20195
- Constructed from marine grade materials & fixings.
- Stove enamel paint finish.
- Remote pan rotation 385°.
- Remote elevation control $\pm 20^\circ$.
- Full variable speed gearbox 1 - 20°/sec (Pan) 1 - 10°/sec Tilt).
- Operational temperature -50°C .
- Adjustable lamp focus, 1.5° spot to 10° flood.
- Remote focus fitted as standard.
- Well proven and reliable power supply unit suitable for 50/60 Hz 1ph power supplies.
- Sealing – IP66 Gearbox, IP56 Searchlight, IP20 PSU
- Supplied with new compact variable speed joystick control panel.
- **Power supply weight 65.9 Kgs.**
- **Searchlight weight 76 Kgs.**
- **Range 10,400 metres.**
- **Peak Beam Candle Power 108 million.**

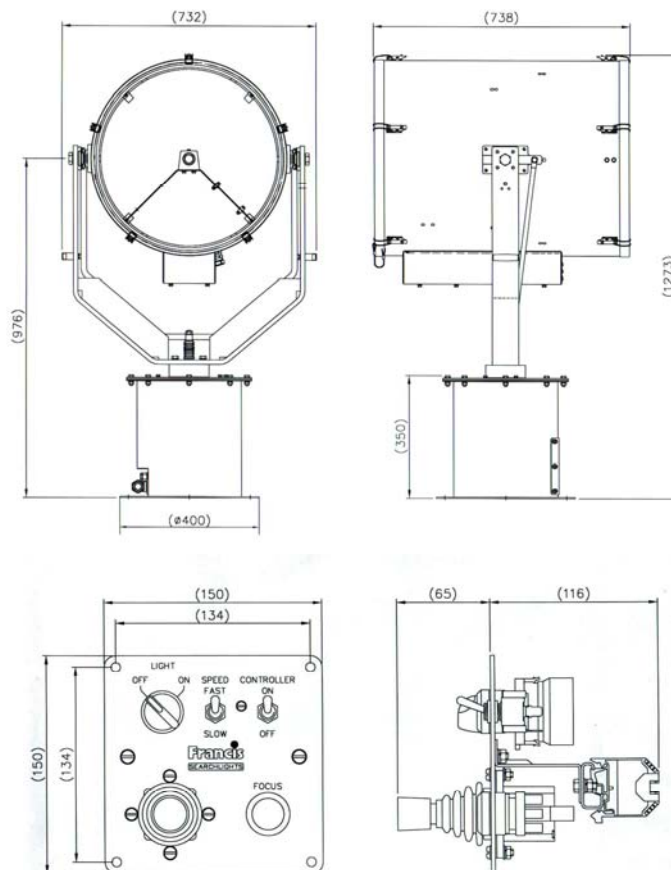

All dimensions in Millimeters

BASE FIXING DETAILS:
4 HOLES 12.5 DIA EQUI-SPACED
ON A 350mm PCD

Part Numbers

Type	Supply	Watts	Part No
FX560RC	240v	2000w	A2471
FX560RC	115v	2000w	A2473

PSU dimensions : 483 X 380 X 305mm

Fixing dimensions : 440 X 152mm

For more information contact:

Francis Searchlights Limited
Union Road, Bolton, BL2 2HJ, UK
Tel 44 (0) 1204 558960 Fax 44 (0) 1204 558979
Email sales@francis.co.uk Web site www.francis.co.uk