



LX300RC Issue 2
Xenon 150w
Remote Control

APPLICATION

THE FRANCIS LX EXPLORER is part of Xenon range of Remote Control searchlights which have designed with the precise aim of bringing to the market, the ultimate searchlight able to guarantee high performance, strength and affordability.

The LX300RC Explorer has been carefully developed to withstand the extraordinary conditions while in use in the harshest of environment, such as Coast Guard patrol. The Heavy duty gearbox is strong, powerful and able to operate in the rough seas and high strength winds as found in coastal areas such as Canada and Scandinavia. This range now also has the added benefit of a heater fitted to the gearbox and searchlight as standard, allowing an operation temperature of up to -50°C.

Within the Francis Lite range of marine searchlights, the LX300, utilising a 150w xenon lamp, has been designed to give maximum beam range and candlepower, which DC incandescent halogen lamps are unable to achieve. Having the ability to identify objects and potential dangers from a far greater distance, the LX300 can prevent both vessel and lives being put to risk. As an optional extra, this unit is also available with infra-red night vision ensuring total covert surveillance

SPECIFICATION

- Immediate full lamp brilliance from switch on.
- Instant re-strike. No "cooling" down time required.
- Toughened front glass.
- Parabolic super pure aluminium reflector.
- Economical 1200 hour lamp life.
- Constructed from stainless steel with stove enamel paint finish.
- Operational temperature -50°C.
- Remote elevation control +30° to -30°.
- Remote pan rotation 365°.
- Sealing - IP66 Searchlight, IP66 PSU.
- Searchlight weight 30.5 Kgs, PSU weight 6.6kgs
- Range 2465m
- Peak Beam Candle Power 6 million
- Optional infra red filter
- Lamp part number D8151

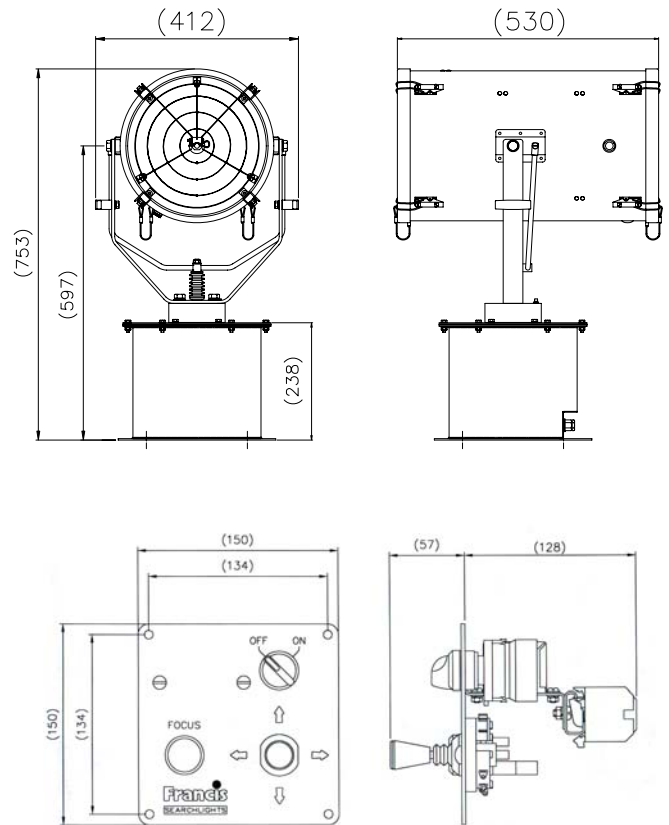

All dimensions in Millimeters

BASE FIXING DETAILS:

4 HOLES 12.5 DIA. EQUI-SPACED ON A 290mm PCD.

Type	Supply	Watts	Part No
LX300RC	110/240 V	150 w	A2619

Francis Searchlights Limited
Union Road, Bolton, BL2 2HJ, UK
Tel 44 (0) 1204 558960 Fax 44 (0) 1204 558979
Email sales@francis.co.uk Web site www.francis.co.uk

For more information contact: