



LX300RC Issue 2
Xenon 500w
Remote Control

APPLICATION

THE NEW FRANCIS LX EXPLORER is part of the premium Range of Remote Control searchlights has been designed with the precise aim of bringing to the market, the ultimate searchlight able to guarantee high performance, strength and affordability. The Premium LX300RC Explorer has been carefully developed to withstand the extraordinary conditions while in use in the harshest of environment, such as Coast Guard patrol, security and Prisons applications. The Heavy duty gearbox is strong, powerful and able to operate in the roughest conditions. This range now also has the added benefit of a heater fitted to the gearbox and searchlight as standard, allowing an operation temperature of up to -50°C.

Within the Francis Lite range of marine searchlights, the LX300, utilising a 500w xenon lamp, has been designed to give maximum beam range and candlepower, which DC incandescent halogen lamps are unable to achieve. Having the ability to identify objects and potential dangers from a far greater distance, the LX300 can prevent both vessel and lives being put to risk. As an optional extra, this unit is also available with infra-red night vision ensuring total covert surveillance

SPECIFICATION

- Immediate full lamp brilliance from switch on.
- Instant re-strike. No "cooling" down time required.
- Toughened front glass.
- Parabolic aluminium reflector.
- Economical 2500 hour lamp life.
- Constructed from stainless steel with stove enamel paint finish.
- Operational temperature -50°C.
- Divergence 1.5 – 10 degrees
- Remote elevation control +30° to -30°.
- Remote pan rotation 365°.
- Sealing - IP66 Searchlight, IP20 PSU.
- Searchlight weight 33.2 Kgs, PSU weight 7.7kgs
- Range 3675m
- Peak Beam Candle Power 14.1 million
- Optional infra red filter
- Lamp part number D20322
- Complete with Joystick control with remote focus

Francis Searchlights Limited
Union Road, Bolton, BL2 2HJ, UK
Tel 44 (0) 1204 558960 Fax 44 (0) 1204 558979
Email sales@francis.co.uk Web site www.francis.co.uk

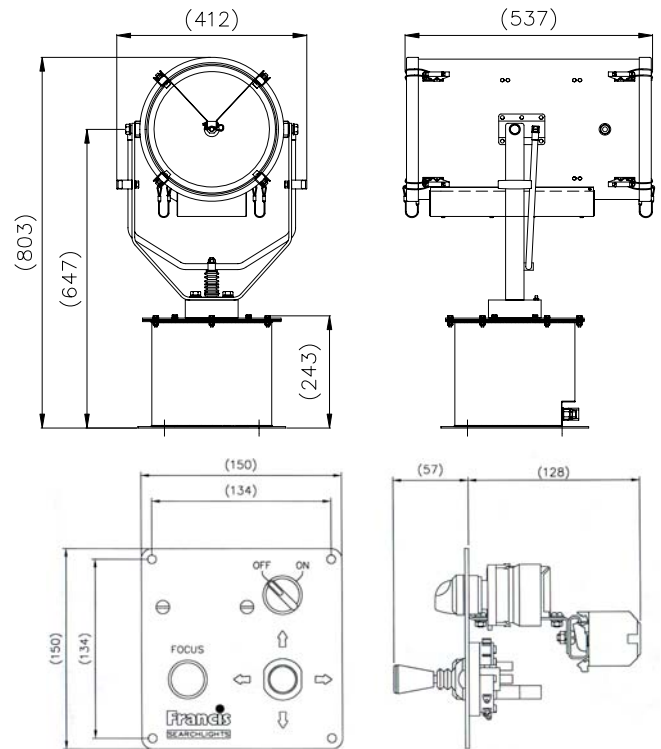

All dimensions in Millimeters

BASE FIXING DETAILS:

4 HOLES 12.5 DIA. EQUI-SPACED ON A 290mm PCD.

Type	Supply	Watts	Part No
LX300RC	110/240 V AC	500 w	A

For more information contact: