



APPLICATION

The new Francis LED searchlight range has been developed to offer an Efficiently and Environmentally Friendly alternative to traditional lamp sources. Using the highest grade of LED developed for the automotive industry, this range offers a high power output with low power consumption, and importantly at a cost effective price. In addition, the LED lamp offers a lamp life up to 50,000 hours. The 40w LED has colour temperature of 6000 k and gives illumination characteristics similar to that of a 125w halogen lamp.

As with all Francis products, the construction is robust and of the highest quality.

SPECIFICATION

- Cost effective LED searchlight
- 50,000 lamp life hours.
- Colour temperature of 6000k (similar to Xenon)
- Toughened super clear Optiwhite front glass.
- Aluminum precision reflector.
- Constructed from marine grade materials and fixings.
- Powder coated and stove enamel paint finish
- Tilt elevation control $\pm 35^\circ$, Rotation 360° .
- Sealing – IP66 Searchlight
- Searchlight weight 4kgs
- Operational temp -50° .
- Fixed focus giving 5° divergence giving good range and illumination.
- Available as a deck version or with a cabin under deck control handle.
- Perfect for RIBS and small vessels.

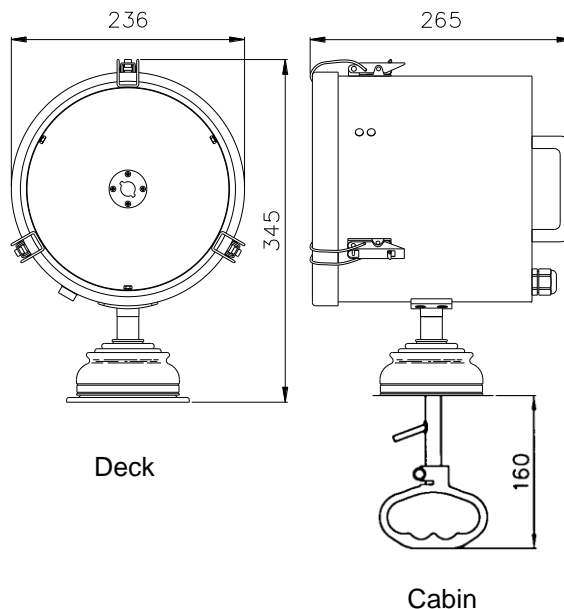

ALL DIMENSIONS IN MILLIMETRES

Base fixing details:
3 holes $\varnothing 6.4$ on a 108 P.C.D.
Under deck control clearance hole $\varnothing 45$.

Part Numbers

Type	Supply	Part No
L230 LED Deck	12/24v	A6158
L230LED Cabin	12/24v	A6159

VAC	Lamp life	Range @ 1 Lux	Luminous Flux	Div	Watts
12/24v	50,000 hrs	500m	4800	5°	40w

For more information contact: