



User Instruction & Installation Manual

FSP300 Signalling Projector



Product Reference Number:

A4184 – DECK L.V.
A4188 – DECK H.V 300W.
A4187 – DECK PEDESTAL H.V.

A4185 – DECK H.V.
A4186 – DECK PEDESTAL L.V.
A4189 – DECK PEDESTAL H.V. 300W

Manufacturers details:

Francis Searchlights Ltd
Union Road, Bolton
Lancashire, BL2 2HJ, UK
Tel: +44 (0) 1204 558960
Fax: +44 (0) 1204 558979
<http://www.francis.co.uk>
E-mail: sales@francis.co.uk

Distributor details:

Manual Part Number: C14855

Issue : 5

CONTENTS

- 1 - Introduction
- 2 - Safety Precautions
- 3 - Technical Information
- 4 - Unpacking and Installation Instructions
- 5 - Electrical Installation
- 6 - Operating Instructions
- 7 - Fault Finding
- 8 - Maintenance and Servicing
- 9 - General Assemblies
- 10 - Spare Parts List

1 - Introduction

It is imperative that this manual is read carefully and understood before installing your equipment. For your future reference please keep this manual in a safe place.

Thank you for specifying a product from the Francis Searchlights range. All Francis products are designed to give complete customer satisfaction and are manufactured to the highest engineering standards in order to ensure optimum performance and service life.

The Francis FSP range combines features proven over many years service in the most hazardous conditions in both marine and land installations.

In order to prolong the life and performance of your product, we recommend that you only specify Francis Searchlights spare parts. This will also ensure that any warranties on your equipment will not be invalidated. Information on spares ordering and parts is provided in this manual.

Should you ever need to contact Francis Searchlights Ltd. regarding your equipment, please quote the Product Serial Number at all times.

2 - Safety Precautions

The following instructions must be adhered to, in order to ensure a safe working environment and the safety of the user.

Note: When unpacking or manoeuvring the searchlight into its fixing position, suitable lifting points must be used in order to prevent damage to the equipment or personal injury.

- Because of the high internal pressure within the lamp, there is a risk of explosion in either a hot or cold state;
- During operation this lamp emits intense UV radiation which is harmful to the eyes and skin. Suitable protection should be worn;
- The high luminance of the arc can cause severe damage to the eye if viewed directly. ALWAYS wear suitable protective goggles when viewing the lamp;
- Always use protective sleeves supplied with the lamp;
- Should it be necessary to examine the lamp with the rear bezel removed, always use a protective shield and wear goggles to ensure a safe working environment;
- Searchlights get hot. Never touch the unit when lit and always allow 15 to 20 minutes for cooling down after turning the searchlight off;
- Never place anything on or cover the searchlight when in use;
- Ensure the lamp has cooled sufficiently before removal;
- If undue force appears necessary to remove the lamp, the equipment should be inspected by a competent person or contact the manufacturer;
- When disposing of lamps, return the lamp, via the supplier, to the lamp manufacturer in its complete packaging;
- Due to the vast range of lamps available it may appear possible that more powerful lamps can be used in the equipment than for which it was designed. Even when the unit will physically accept a higher wattage or voltage lamp, this substitution is not recommended and is dangerous. This action will also void any warranties on the equipment.
- Always refer to the lamp manufacturers technical data when dealing with lamps.

3 – Technical Information

This product has been designed to operate in accordance with the product specification. The FSP300 searchlight has the following features:

- All marine grade materials and fixings;
- Parabolic glass reflector;
- Stove enamel painted;
- Full 360° horizontal rotation;
- Vertical movement +45° to -45°;
- External lamp focus adjustment;
- Toughened front glass;
- Sealing to IP56;
- Tungsten Halogen light source;
- Deck 19.3 Kgs
- Deck Pedestal 23.9 Kgs

The searchlight also performs to the following optical data:

Volts	Watts	Range @ 1 Lux	P.B.C.P. x 1000	Div.	Lamp Life	Lamp Cap	Part Number
12v	100w	1019M	1038	2°	2000 hrs	GX6.35	D9848
24v	150w	1106M	1224	2°	300 hrs	GX6.35	D14795
24v	250w	1298M	1685	3°	2000 hrs	GX6.35	D4695
24v	250w	1563M	2442	3°	300 hrs	GX6.35	D9851
230v	300w	580M	337	3°	75 hrs	GX6.35	D16841
115v	300w	597M	356	3°	75 hrs	GX6.35	D16883
230v	650w	950M	902	5°	750 hrs	GX9.5	D1813
115v	1000w	1049M	1100	5°	750 hrs	GX9.5	D1809
230v	1000w	1017M	1034	5°	750 hrs	GX9.5	D6715

In order that the searchlight operates correctly it is imperative that competent personnel are responsible for the installation, operation and servicing of this equipment. Failure to adhere to this advice may cause premature failure or incorrect operation of the searchlight, which may damage the equipment or cause personal injury.

4 - Unpacking and Installation Instructions

The following instructions should be read and fully understood prior to installing the equipment to ensure that the correct procedures are followed and all safety precautions are observed.

Note: If the equipment has been in storage for a considerable amount of time, it is advisable to conduct a routine maintenance check on all parts before installation.

Safety Precautions

This equipment should not be connected to an electrical supply before being installed. Installation procedures should be adhered to in order to ensure a safe working environment and reduce the risk of damage or personal injury.

Preparing the Mounting Position

Mark out and drill the fixing holes through the deck. If anti-vibration mounts are to be fitted, the fixing holes for the mounts should also be marked out and drilled. Prior to manoeuvring the searchlight into its' fixing position, the AV mounts should be fitted to the base. When in the desired position, bolt the searchlight firmly down.

5 - Electrical Installation

For safety purposes, only competent personnel should perform the electrical installation. All equipment should be installed to current Electrical Regulations and Standards.

In order to obtain the maximum light output from the searchlight, it is essential that the full operating voltage of the lamp fitted be applied to the lampholder contacts.

Method of Electrical Connection

- 1) Disconnect the supply before working on the electrical system;
- 2) The searchlight must be connected to a fused electrical supply, using suitably sized cable;
- 3) If the searchlight is located a considerable distance from the supply, provision must be made in the cable size in order to overcome the voltage drop. The following table should be used for indication purposes only:

Searchlight	12v 100w	24v 150w	24v 250w	230v 300w
Cable Size (mm ²)	Distance Max	Distance Max	Distance Max	Distance Max
1.5	2 MTRS	5 MTRS	3 MTRS	228 MTRS
2.5	3 MTRS	8 MTRS	5 MTRS	372 MTRS
4.0	5 MTRS	13 MTRS	8 MTRS	589 MTRS
6.0	7 MTRS	20 MTRS	12 MTRS	919 MTRS
10.0	12 MTRS	34 MTRS	20 MTRS	1538 MTRS

Searchlight	230v 650w	115v 300w	115v 1000w	230v 1000w
Cable Size (mm ²)	Distance Max	Distance Max	Distance Max	Distance Max
1.5	105 MTRS	57 MTRS	17 MTRS	68 MTRS
2.5	171 MTRS	93 MTRS	28 MTRS	111 MTRS
4.0	271 MTRS	147 MTRS	44 MTRS	176 MTRS
6.0	422 MTRS	229 MTRS	69 MTRS	275 MTRS
10.0	707 MTRS	384 MTRS	115 MTRS	460 MTRS

- 4) Whenever possible cable terminations should be made below deck and with approved terminal devices;
- 5) If a spare auxiliary fuse or circuit breaker is not available, one of the correct type and rating should be fitted and connected to a positive supply. It is advisable to locate a bus bar or main connection and avoid any direct connection to the supply;
- 6) For 110/220v AC products, the following colour coding system should be used for the customer supply cable:

Brown - Live
 Blue - Negative
 Green/Yellow - Earth

Note: This equipment must be earthed.

6 - Operating Instructions

This equipment is designed for use out of doors, in free air. Never place anything on, or cover, the searchlight when in use as this may present a hazard.

The FSP300 signalling projector can be used for signalling or as a searchlight. To use as a searchlight pull down the signalling lever so that the shutter is in the open position. Remove the shutter stop pin, which is attached to the crutch and insert into the lever guide bracket.

The beam of the searchlight can be adjusted to give a variety of beam types. Using the lampholder focus wheel, the desired beam can be achieved for any particular application.

This product should not be used for any purpose other than for which it was designed. Any modifications to the product should not be undertaken without consulting the manufacturer.

Setting to Work

Safe service in use necessitates the strict observance of the following precautions.

- Any article fabricated from quartz or glass is inherently fragile and care should therefore be taken, at all times, when handling lamps;
- Eye protection must be worn when handling lamps that have been removed from their packaging materials. The protective sleeve should not be removed from the lamp for safety reasons, as there is a remote possibility of the lamp shattering violently, especially if it is subjected to mechanical shock or vibration;
- Ensure that the power rating of the lamp to be fitted is suitable for the lamphouse and power supply equipment;
- Always isolate the equipment from the supply before inserting a lamp;
- Before inserting the lamp ensure that all contacts are clean. Contacts must be renewed at the slightest sign of corrosion. Sanding or filing down corroded areas is not recommended as this will only make the conducting surface between the pin and lampholder smaller, thus causing the lamp to overheat;
- Do not twist or bend the fused quartz bulb when fitting the lamp as mechanical stresses MUST be avoided;
- When inserting or removing a lamp, always hold it securely by its' base in order to prevent breakage between base and bulb;
- The lampholder must not exercise mechanical tensions on the lamp, neither during insertion or operation. Contacts must not discolour during use;
- For safety reasons, the lamp should be replaced once it has reached its' average life, and not later than 1.25 times the stated life. With continuing use the risk of the lamp exploding increases due to alterations within the quartz;
- Before the protective sleeve is removed, suitable protection must be worn i.e face mask and gloves with wrist protection;
- Never touch the quartz bulb with bare hands, as fingerprints will make the glass cloudy and cause a severe loss of light. This may also cause recrystallisation and thus weaken the bulb material. Should the bulb be inadvertently touched, remove fingerprints with methylated spirit and a clean, soft paper towel. The bulb should then be wiped with distilled water. NOTE: ALWAYS WEAR MASK AND GLOVES DURING CLEANING);
- All packaging and the protective sleeve must be retained for re-use. Whenever removing a lamp, the protective sleeve must always be used for safety reasons;

In all circumstances the lamp manufacturers data should be referred to when dealing with lamps.

7- Fault Finding

All fault finding must be conducted by a competent person or qualified Electrical Engineer.

Failure of Lamp to ignite

Causes:

- 1) Power not supplied;
- 2) Fuse blown;
- 3) Failed lamp;

Remedy:

- 1) Check voltage at supply. If supply is not present the fault is at the customer supply. If power is present, see remedy 2;
- 2) Check fuse for visual failure. If none noticeable check fuse for continuity using a multimeter. If fuse found to be faulty, replace with new part and test equipment again for correctly working order. If found to be working correctly see remedy 3;
- 3) Firstly, check supply at lampholder connecting block (within searchlight barrel). If supply is present, disconnect unit from power supply before removing the lamp. If noticeable damage to filament is present, the lamp will have failed. The lamp can also be checked for continuity using a multimeter. Replace lamp ensuring all precautions and instructions previously outlined in this manual are adhered to.

8 - Maintenance and Servicing

In order to prolong the service life and performance of your searchlight, the following maintenance guidelines are recommended:

- Maintenance checks should be conducted before every voyage or at least every three months;
- Before checking, disconnect the equipment from the supply;
- Visually inspect the condition of the equipment;
- Any major or minor structural damage should be rectified immediately in order to reduce sympathetic wear;
- After inspection it may be necessary to clean the inside of the searchlight. The following procedure should be adhered to:
 - Remove the front bezel;
 - Clean the front glass inside and out using a proprietary glass cleaner or metal polish;
 - Clean the reflector if required;
 - Check the reflector mounting gaskets. If signs of corrosion or damage are evident, replace as necessary;
 - Ensure that the lampholder is free from corrosion or other damage;
 - Check earthing point for conductivity;
- It is advisable to check all seals and gaskets for signs of degradation. Renew if necessary;
- Upon completing all maintenance requirements the searchlight should be tested for full working order (approximately 20 minutes).
- Every six months the external movement mechanisms i.e. lockwheels, should be lightly lubricated.

If in any doubt as to the correct servicing procedures to adopt please contact your distributor/agent or the manufacturer who will be able to advise the best course of action for your product.

9 – General Assemblies

Drawing Number	Description
A4184	FSP300 Deck L.V.
A4185	FSP300 Deck H.V.
A4188	FSP300 Deck H.V. 300w
A4186	FSP300 Deck Pedestal L.V.
A4187	FSP300 Deck Pedestal H.V.
A4189	FSP300 Deck Pedestal H.V. 300w

FIRST USED ON
L.V. FSP 3000

DO NOT SCALE DRAWING

THIRD ANGLE PROJECTION

1 2 3 4 5 6 7 8 9 10 11 12 13 14 15 16

15 16

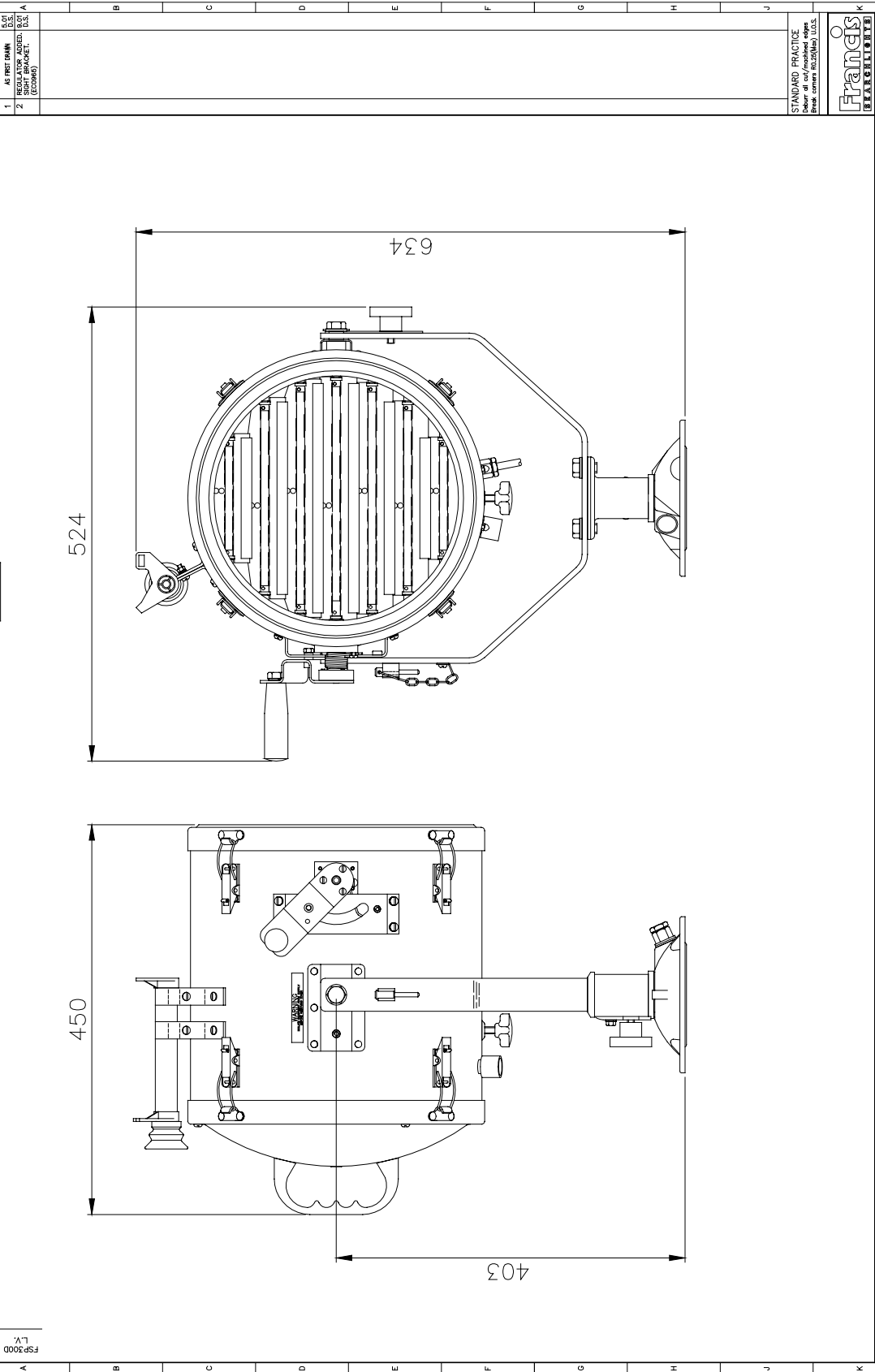

1	2	3	4	5	6	7	8	9	10	11	12	13	14	15	16
DRAWN: D.S.		DATE: 3.15.01		TOLERANCES:		Sand Castings To ISO 8402 C10		General: #		MATERIAL:		FRANCIS SEARCHLIGHTS LIMITED · UNION ROAD · BOLTON · BL2 2HJ		© 2001 A1 CONT ON SHEET	
CHECKED: L.V.		SCALE: 1:2		General: #		DIN Castings To ISO 8402 C10		Finish: #		DESCRIPTION: FSP 300 L.V. G.A.		PART No./REV No:		A4184 2	
ALL DIMENSIONS IN MILLIMETRES		Apply: #		Hole centres & posits: #										STANDARD PRACTICE Refer to cut/finished edge Break corners R0.25(Max) U.L.S.	

DO NOT SCALE DRAWING

THIRD ANGLE PROJECTION

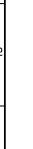

FRANCIS SEARCHLIGHTS LIMITED UNION ROAD BOLTON BL2 2HU

FSP 300 H.V. G.A.

STANDARD PRACTICE
 British Standard BS 5400:1991
 Steel work for buildings

FRANCIS SEARCHLIGHTS LIMITED

UNION ROAD BOLTON BL2 2HU

FSP 300 H.V. G.A.

© 2001 A1 CONT ON SHEET
 PART NO./REV. NO.

STANDARD PRACTICE

FRANCIS SEARCHLIGHTS LIMITED

REV	DESCRIPTION	DATE
1	AS FIRST DRAWN	12.12.00
2	REGULATOR ADDED. (NOT TO SCALE)	12.12.00

16

15

14

13

12

11

10

9

8

7

6

5

4

3

2

1

A

B

C

D

E

F

G

H

J

K

16

15

14

13

12

11

10

9

8

7

6

524

450

634

403

403

403

403

403

403

403

403

403

403

403

403

403

403

403

403

403

403

403

403

403

403

403

403

403

403

403

403

403

403

403

403

403

403

403

403

403

403

403

403

403

403

403

403

403

403

403

403

403

403

403

403

403

403

403

403

403

403

403

403

403

403

403

403

403

403

403

403

403

403

403

403

403

403

403

403

403

403

403

403

403

403

403

403

403

403

403

403

403

403

403

403

403

403

403

403

403

403

403

403

403

403

403

403

403

403

403

403

403

403

403

403

403

403

403

403

403

403

403

403

403

403

403

403

403

403

403

403

403

403

403

403

403

403

403

403

403

403

403

403

403

403

403

403

403

403

403

403

403

403

403

403

403

403

403

403

403

403

403

403

403

403

403

403

403

403

403

403

403

403

403

403

403

403

403

403

403

403

403

403

403

403

403

403

403

403

403

403

403

403

403

403

403

403

403

403

403

403

403

403

403

403

403

403

403

403

403

403

403

403

403

403

403

403

403

403

403

403

403

403

403

403

403

403

403

403

403

403

403

403

403

403

403

403

403

403

403

403

403

403

403

403

403

403

403

403

403

403

403

403

403

403

FIRST USED ON
FSP3000
300w
2.5" H

DO NOT SCALE DRAWING

THIRD ANGLE PROJECTION

REV	DESCRIPTION	DATE
1	AS FIRST DRAWN	D.S.
2	REVISIONS	D.S.

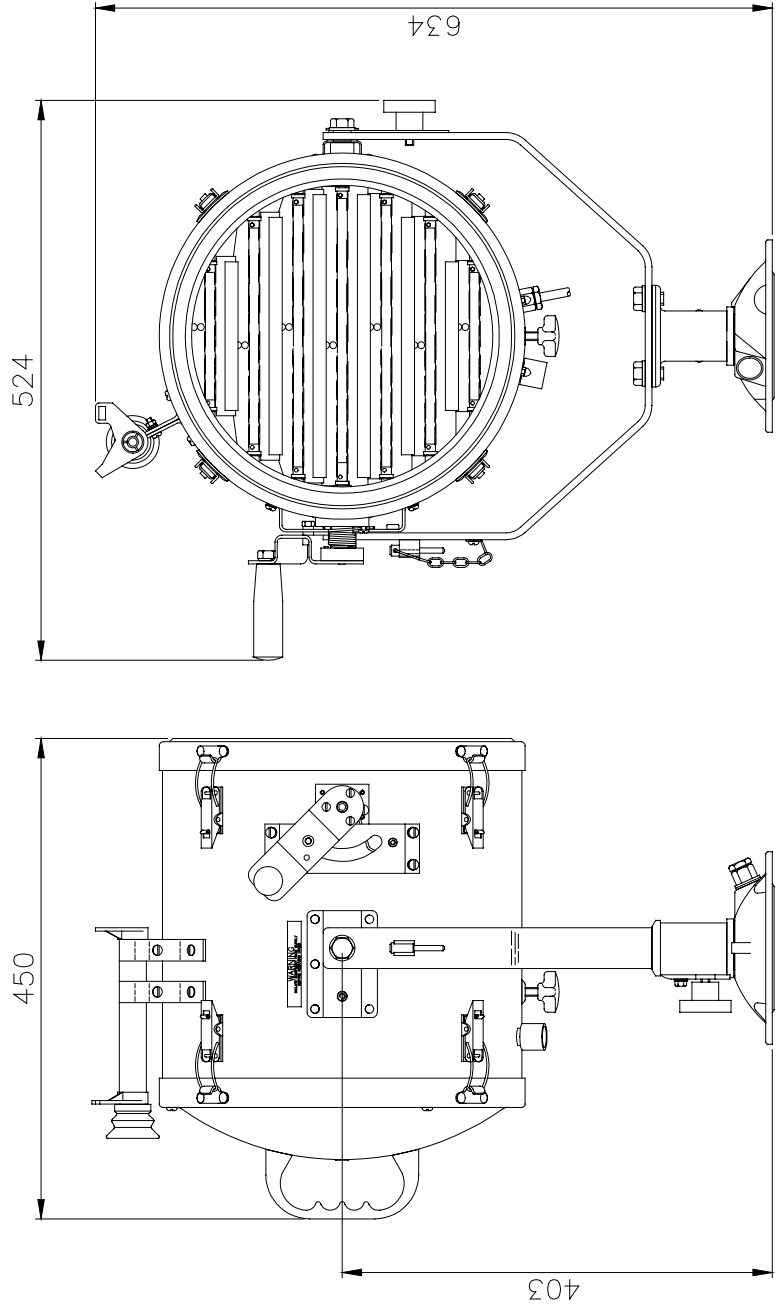

REV	DESCRIPTION	DATE
1	AS FIRST DRAWN	D.S.
2	REVISIONS	D.S.

REV	DESCRIPTION	DATE
1	AS FIRST DRAWN	D.S.
2	REVISIONS	D.S.

STANDARD PRACTICE
Refer to 2nd (reference table)
Refer comment 10020(May) U.S.S.

© 2001 A1 CONT. ON SHEET

PART NUMBER No. A4188 2

FRANCIS SEARCHLIGHTS LIMITED · UNION ROAD · BOLTON · BL2 2HU

FSP300 H.V. 300w G.A.

FINISH

MATERIAL

Some Castings To ISO 8002 CTD
Die Castings To ISO 8005 C7B
Hole centres & patterns ±

DATE 20.9.01 TOLERANCES

General ±
Fines ±

SCALE 1:2

ALL DIMENSIONS IN MILLIMETRES

FRANCIS SEARCHLIGHTS LIMITED · UNION ROAD · BOLTON · BL2 2HU

FSP300 H.V. 300w G.A.

FINISH

MATERIAL

Some Castings To ISO 8002 CTD
Die Castings To ISO 8005 C7B
Hole centres & patterns ±

DATE 20.9.01 TOLERANCES

General ±
Fines ±

SCALE 1:2

ALL DIMENSIONS IN MILLIMETRES

FRANCIS SEARCHLIGHTS LIMITED · UNION ROAD · BOLTON · BL2 2HU

FSP300 H.V. 300w G.A.

FINISH

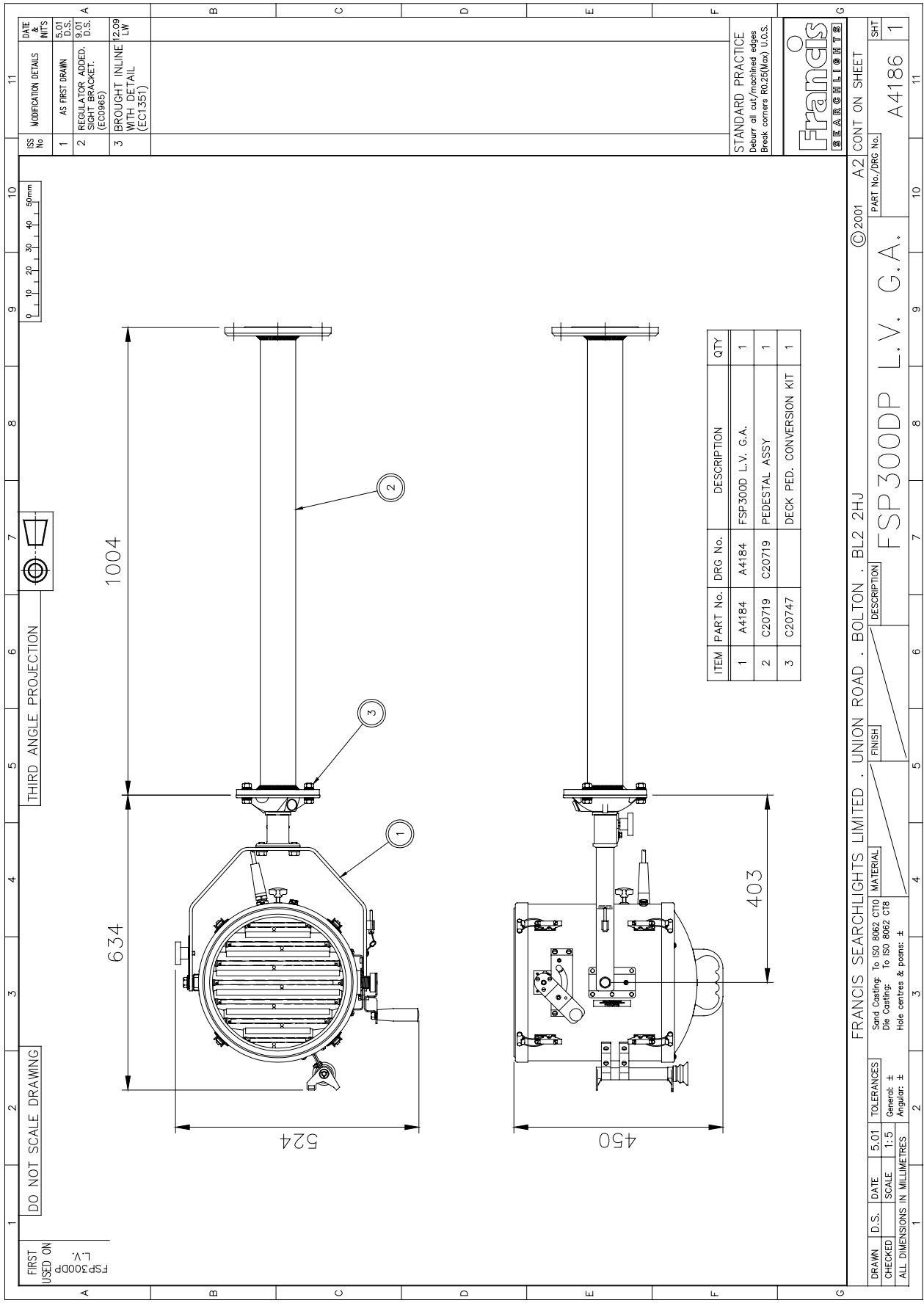

ISS No	MODIFICATION DETAILS	DATE & INIT'S
1	AS FIRST DRAWN	5.01 D.S.
2	REGULATOR ADDED. SIGHT BRACKET. (ECO965)	9.01 D.S.
3	BROUGHT INLINE WITH DETAIL (EC1351)	12.09 LW

STANDARD PRACTICE
Deburr all cut/machined edges
Break corners R0.25(Max) U.O.S.



© 2001	A2	CONT ON SHEET
PART No./DRG No.	A4186	
SHT	1	

ITEM	PART No.	DRG No.	DESCRIPTION	QTY
1	A4184	A4184	FSP300D L.V. G.A.	1
2	C20719	C20719	PEDESTAL ASSY	1
3	C20747		DECK PED. CONVERSION KIT	1

FRANCIS SEARCHLIGHTS LIMITED . UNION ROAD . BOLTON . BL2 2HU	
FINISH	DESCRIPTION
MATERIAL	FSP300DP L.V. G.A.
SAND CASTING: To ISO 8062 CT10	
DIE CASTING: To ISO 8062 C18	
HOLE CENTRES & POSITS: ±	
TOLERANCES	
SCALE	
1:5	
GENERAL: ±	
ANGULAR: ±	
ALL DIMENSIONS IN MILLIMETRES	

11 10 9 8 7 6 5 4 3 2 1

ISS No 1 2 3

MODIFICATION DETAILS DATE & INT'S 9.01 D.S. 9.01 D.S. 12.09 LW

AS FIRST DRAWN D.S. (E00965)

REGULATOR ADDED, SIGHT BRACKET. (E00965)

BROUGHT INLINE WITH DETAIL (E01351)

STANDARD PRACTICE

Deburr all cut/machined edges

Break corners R0.25(Max) U.O.S.

© 2001 A2

CONT ON SHEET

PART No./DRG No. A4189 1

FRANCIS SEARCHLIGHTS

FRANCIS SEARCHLIGHTS LIMITED · UNION ROAD · BOLTON · BL2 2HJ

DESCRIPTION FSP300DP H.V. 300W G.A.

FINISH

Sand Casting: To ISO 8062 CT10

Die Casting: to ISO 8062 C16

Hole centres & posns: ±

TOLERANCES General: ±

Angular: ±

DATE 9.01

DRAWN D.S.

CHECKED SCALE 1:1.5

ALL DIMENSIONS IN MILLIMETRES

DO NOT SCALE DRAWING

THIRD ANGLE PROJECTION

524

634

1004

450

403

1 2 3

ITEM PART No. DRG No. DESCRIPTION QTY

1 A4188 FSP300D H.V. 300w G.A. 1

2 C20719 PEDESTAL ASSY 1

3 C20747 DECK PED. CONVERSION KIT 1

1 2 3 4 5 6 7 8 9 10 11

1 2 3 4 5 6 7 8 9 10 11

A B C D E F G

1 2 3 4 5 6 7 8 9 10 11

1 2 3 4 5 6 7 8 9 10 11

1 2 3 4 5 6 7 8 9 10 11

1 2 3 4 5 6 7 8 9 10 11

1 2 3 4 5 6 7 8 9 10 11

FIRST USED ON

FSP300DP

H.V. 300W

DATE 9.01

DRAWN D.S.

CHECKED SCALE 1:1.5

ALL DIMENSIONS IN MILLIMETRES

DO NOT SCALE DRAWING

THIRD ANGLE PROJECTION

524

634

1004

450

403

1 2 3

ITEM PART No. DRG No. DESCRIPTION QTY

1 A4188 FSP300D H.V. 300w G.A. 1

2 C20719 PEDESTAL ASSY 1

3 C20747 DECK PED. CONVERSION KIT 1

1 2 3 4 5 6 7 8 9 10 11

1 2 3 4 5 6 7 8 9 10 11

A B C D E F G

1 2 3 4 5 6 7 8 9 10 11

1 2 3 4 5 6 7 8 9 10 11

1 2 3 4 5 6 7 8 9 10 11

1 2 3 4 5 6 7 8 9 10 11

1 2 3 4 5 6 7 8 9 10 11

1 2 3 4 5 6 7 8 9 10 11

1 2 3 4 5 6 7 8 9 10 11

1 2 3 4 5 6 7 8 9 10 11

1 2 3 4 5 6 7 8 9 10 11

1 2 3 4 5 6 7 8 9 10 11

1 2 3 4 5 6 7 8 9 10 11

1 2 3 4 5 6 7 8 9 10 11

1 2 3 4 5 6 7 8 9 10 11

1 2 3 4 5 6 7 8 9 10 11

1 2 3 4 5 6 7 8 9 10 11

1 2 3 4 5 6 7 8 9 10 11

1 2 3 4 5 6 7 8 9 10 11

1 2 3 4 5 6 7 8 9 10 11

1 2 3 4 5 6 7 8 9 10 11

1 2 3 4 5 6 7 8 9 10 11

1 2 3 4 5 6 7 8 9 10 11

1 2 3 4 5 6 7 8 9 10 11

1 2 3 4 5 6 7 8 9 10 11

10 – Spare Parts List

The following spare parts can be ordered directly from the manufacturer:

Part Number	Description
D1813	230v 650w T/H GX9.5 Lamp
D1809	115v 1000w T/H/ GX9.5 Lamp
D6715	230v 1000w T/H GX9.5 Lamp
D16841	230v 300w T/H GX6.35 Lamp
D16883	115v 300w T/H GX6.35 Lamp
D9848	12v 100w T/H GX6.35 Lamp
D14795	24v 150w T/H GX6.35 Lamp
D4695	24v 250w T/H GX6.35 Lamp (Long life)
D9851	24v 250w T/H GX6.35 Lamp
C11025	Lockwheel Assy
C02512	Shutter return spring
C01461	Eyepiece
C01916	Front glass
C10021	Front glass gasket
C11014	Front glass/dome seal
C05403	Reflector
C21653	Reflector gasket
C21644	Lampholder assembly complete GX9.5
C21671	Lampholder assembly complete GX6.35
C21871	Lampholder assembly complete GX6.35 300w
C08827	Lampholder spring
C09888	Focus wheel assembly
C03022	Lampholder GX9.5
C16878	Lampholder GX6.35
C10168	'O' ring seal Deck base
C20634	'O' ring seal Pedestal base
C21535	Infra-red glass
C22268	Breather

In order to prolong the life and performance of your product, we recommend that you only specify Francis Searchlights spare parts. This will ensure that any warranties on your equipment will not be invalidated.

When ordering spare parts please contact the Sales Department at Francis Searchlights Limited. Please quote searchlight model and serial number at all times. This will enable a fast response to your spares' requirements.