



User Instruction & Installation Manual

FR380 Remote Control Explorer Tungsten Halogen Searchlight



Product Reference Number:

A2542 – FR380RC Explorer 115/240v 650/1000w

A2541 – FR380RC Explorer 24v 150/250w

Manufacturers details:

Francis Searchlights Ltd
Union Road, Bolton
Lancashire, BL2 2HJ, UK
Tel: +44 (0) 1204 558960
Fax: +44 (0) 1204 558979
<http://www.francis.co.uk>
E-mail: sales@francis.co.uk

Distributor details:



Manual Part Number: C23299

Issue : 4

CONTENTS

- 1 - Introduction
- 2 - Safety Precautions
- 3 - Technical Information
- 4 - Unpacking and Installation Instructions
- 5 - Electrical Installation
- 6 - Operating Instructions
- 7 - Fault Finding
- 8 - Maintenance and Servicing
- 9 - Wiring Diagrams & General Assembly
- 10 - Spare Parts List

1 - Introduction

It is imperative that this manual is read carefully and understood before installing your equipment. For your future reference please keep this manual in a safe place.

Thank you for specifying a product from the Francis Searchlights range. All Francis products are designed to give complete customer satisfaction and are manufactured to the highest engineering standards in order to ensure optimum performance and service life.

The Francis FR range combines features proven over many years service in the most hazardous conditions in both marine and land installations.

In order to prolong the life and performance of your product, we recommend that you only specify Francis Searchlights spare parts. This will also ensure that any warranties on your equipment will not be invalidated. Information on spares ordering and parts is provided in this manual.

Should you ever need to contact Francis Searchlights Ltd. regarding your equipment, please quote the Product Serial Number at all times.

2 - Safety Precautions

The following instructions must be adhered to, in order to ensure a safe working environment and the safety of the user.

Note: When unpacking or manoeuvring the searchlight into its fixing position, suitable lifting points must be used in order to prevent damage to the equipment or personal injury.

- Prevent rain, snow, condensation and water droplets from contacting the lamp as this may cause bulb failure and possible shattering;
- Quartz halogen bulbs run with a high internal pressure in excess of atmospheric. Whilst the construction is inherently strong, there is a slight risk of the bulb shattering;
- Never look directly into an illuminated searchlight as this may cause severe damage to eyesight. If it is necessary to inspect a lamp whilst in operation, always wear suitable protective goggles;
- Should it be necessary to examine the lamp with the front bezel removed, always use a protective shield and wear goggles to ensure a safe working environment;
- Never attempt to clean a lamp whilst in use;
- Searchlights get hot. Never touch the unit when lit and always allow 15 to 20 minutes for cooling down after turning the searchlight off;
- Never place anything on or cover the searchlight when in use;
- Ensure the lamp has cooled sufficiently before removal;
- If undue force appears necessary to remove the lamp, the equipment should be inspected by a competent person or contact the manufacturer;
- When breaking a lamp for disposal, care must be taken to ensure the glass fragments are safely contained. This operation must be performed out of doors in free air. In all circumstances refer to the lamp manufacturers instructions packed with the lamp;
- Due to the vast range of lamps available it may appear possible that more powerful lamps can be used in the equipment than for which it was designed. Even when the unit will physically accept a higher wattage or voltage lamp, this substitution is not recommended and is dangerous. This action will also void any warranties on the equipment.

Always refer to the lamp manufacturers technical data when dealing with lamps.

3 - Technical Information

This product has been designed to operate in accordance with the product specification. The FR380RC searchlight has the following features:

- All marine grade materials and fixings;
- Parabolic glass reflector;
- Stove enamel painted;
- 365° horizontal rotation;
- Vertical movement +25° to -25°;
- Motor speed 20°/sec (Pan), 5°/sec (Tilt);
- Remote focus facility;
- Thermostatically controlled internal heater.(Optional);
- Toughened front glass;

The 24v searchlight also performs to the following optical data:

	<u>150 Watt T/H</u>	<u>250 Watt T/H</u>
■ Supply voltage	24v	24v
■ Peak Beam Candlepower	1718,000 lux	2800,000 lux
■ Range	1311 metres	1673 metres
■ Divergence	2°	3°
■ Operational temperature with heater	-50°C (-20° without)	-50°C (-20° without)

The 115v searchlight also performs to the following optical data:

	<u>1000 Watt T/H</u>
■ Supply voltage	115v
■ Peak Beam Candlepower	1560,000 lux
■ Range	1249 metres
■ Divergence	5°
■ Operational temperature with heater	-50°C (-20° without)

The 220/240v searchlight also performs to the following optical data:

	<u>650 Watt T/H</u>	<u>1000 Watt T/H</u>
■ Supply voltage	220/240v	220/240v
■ Peak Beam Candlepower	1240,000 lux	1465,000 lux
■ Range	1114 metres	1210 metres
■ Divergence	5°	5°
■ Operational temperature with heater	-50°C (-20° without)	-50°C (-20° without)

In order that the searchlight operates correctly it is imperative that competent personnel are responsible for the installation, operation and servicing of this equipment. Failure to adhere to this advice may cause premature failure or incorrect operation of the searchlight, which may damage the equipment or cause personal injury.

4 - Unpacking and Installation Instructions

The following instructions should be read and fully understood prior to installing the equipment to ensure that the correct procedures are followed and all safety precautions are observed.

Note: If the equipment has been in storage for a considerable amount of time, it is advisable to conduct a routine maintenance check on all parts before installation.

Safety Precautions

This equipment should not be connected to an electrical supply before being installed. Installation procedures should be adhered to in order to ensure a safe working environment and reduce the risk of damage or personal injury.

Preparing the Mounting Position

Mark out and drill the fixing holes through the deck refer to drawing C23290). If anti-vibration mounts are to be fitted, the fixing holes for the mounts should also be marked out and drilled. Prior to manoeuvring the searchlight into its' fixing position, the AV mounts should be fitted to the base. When in the desired position, bolt the searchlight firmly down. On an uneven surface it may be necessary to use a suitable sealant such as silicone, in order to ensure a weatherproofed joint.

5 - Electrical Installation

For safety purposes, only competent personnel should perform the electrical installation. All equipment should be installed to current Electrical Regulations and Standards.

In order to obtain the maximum light output from the searchlight, it is essential that the full operating voltage of the lamp fitted be applied to the lampholder contacts.

Method of Electrical Connection

- 1) Disconnect the supply before working on the electrical system;
- 2) The searchlight must be connected to a fused electrical supply, using suitably sized cable;
- 3) If the searchlight is located a considerable distance from the supply, provision must be made in the cable size in order to overcome the voltage drop. The following table should be used for indication purposes only:

Searchlight	24v 150w	24v 250w	115v 1000w	230v 1000w	230v 650w
Cable Size (mm ²)	Distance Max	Distance Max	Distance Max	Distance Max	Distance Max
1.5	5 MTRS	3 MTRS	17 MTRS	68 MTRS	105 MTRS
2.5	8 MTRS	5 MTRS	28 MTRS	111 MTRS	171 MTRS
4	13 MTRS	8 MTRS	44 MTRS	176 MTRS	271 MTRS
6	20 MTRS	12 MTRS	69 MTRS	275 MTRS	422 MTRS
10	34 MTRS	20 MTRS	115 MTRS	460 MTRS	707 MTRS

- 4) Whenever possible cable terminations should be made below deck and with approved terminal devices;
- 5) If a spare auxiliary fuse or circuit breaker is not available, one of the correct type and rating should be fitted and connected to a positive supply. It is advisable to locate a bus bar or main connection and avoid any direct connection to the supply;
- 6) For 110/220v AC products, the following colour coding system should be used for the customer supply cable:

Brown - Live
Blue - Negative
Green/Yellow - Earth

Note: This equipment must be earthed.

Installation Guidelines

A typical installation and connection routine for the FR380RC Low Voltage searchlight is as follows:

Referring to wiring diagram C23291, a supply is fed to the control panel, which then provides a common feed to the motor gearbox and the searchlight.

The searchlight has been pre-wired with 3 meters of cable from the gearbox to junction box provided.

Cables required to be connected by the customer: -

4 core 1.5mm cable from the junction box to the Control Panel.

12 core 0.5mm cable from the junction box to the Control Panel.

The Mains cable to the Control Panel to be supplied by the customer. The searchlight head is pre-wired along with the connecting cable to the motor gearbox.

A typical installation and connection routine for the FR300RC High Voltage searchlight is as follows:

Referring to wiring diagram C23293, a supply is fed to the control panel, which then provides a common feed to the motor gearbox and the searchlight.

The searchlight has been pre-wired with 3 meters of cable from the gearbox to junction box provided.

Cables required to be connected by the customer: -

4 core 1.5mm cable from the junction box to the Control Panel.

12 core 0.5mm cable from the junction box to the Control Panel.

The Mains cable to the Control Panel to be supplied by the customer. The searchlight head is pre-wired along with the connecting cable to the motor gearbox.

6 - Operating Instructions

This equipment is designed for use out of doors, in free air. Never place anything on, or cover the searchlight when in use as this may present a hazard.

The searchlight can be remotely positioned via the joystick control panel, with the facility for movement up, down, left and right. When in the desired position the joystick should be released so that it returns to its' home position, dead centre.

The beam of the searchlight can be adjusted to give a variety of beam types. Using the yellow remote focus button on the joystick panel, the desired beam can be achieved for any particular application. The beam will move continuously through 'spot' to 'flood'. In order to fix the beam type; simply release the button at the desired position.

The heaters specified on this equipment are self-regulating and will shut off when they reach the dew point temperature.

This product should not be used for any purpose other than for which it was designed. Any modifications to the product should not be undertaken without consulting the manufacturer.

Setting to Work

Safe service in use necessitates the strict observance of the following precautions.

- Any article fabricated from quartz or glass is inherently fragile and care should therefore be taken, at all times, when handling lamps;
- Eye protection must be worn when handling lamps that have been removed from their packaging materials. The protective jacket should not be removed from the lamp for safety reasons, as there is a remote possibility of the lamp shattering violently, especially if it is subjected to mechanical shock or vibration;
- Always isolate the equipment from the supply before inserting a lamp;
- Before inserting the lamp ensure that all contacts are clean. Contacts must be renewed at the slightest sign of corrosion. Sanding or filing down corroded areas is not recommended as this will only make the conducting surface between the pin and lampholder smaller, thus causing the lamp to overheat;
- Do not twist or bend the fused quartz bulb when fitting the lamp as mechanical stresses MUST be avoided;
- The lamp must be capable of unimpeded expansion when it warms up to operating temperature. Mechanical forces must not be applied to the fused quartz bulb;
- Before the protective jacket is removed, suitable protection must be worn i.e face mask and gloves with wrist protection;
- Never touch the quartz bulb with bare hands, as fingerprints will make the glass cloudy and cause a severe loss of light. This may also cause recrystallisation and thus weaken the bulb material. Should the bulb be inadvertently touched, remove fingerprints with methylated spirit and a clean, soft paper towel. The bulb should then be wiped with distilled water. NOTE: ALWAYS WEAR MASK AND GLOVES DURING CLEANING);

In all circumstances the lamp manufacturers data should be referred to when dealing with lamps.

When fitting the lamp:

- Always isolate the equipment from the supply when inserting a lamp;
- Ensure the circuit is suitably fused;
- Ensure the lamp is of the correct power rating and type;
- Check lampholder is in good condition. If the contacts show any sign of corrosion, replace the lampholder;
- Check the lampholder is in a good dry condition. Never allow water to collect in the lamp fitting or come into contact with the lamp.

To fit the lamp:

- Loosen all the thumbscrews on the front of the searchlight, remove the bezel and glass and store in a safe place;
- For easier access the light shield/spill ring may be removed by undoing the fasteners;
- Cut open one end of the protective sleeve surrounding the lamp;
- Using the sleeve to prevent the fingers coming into contact with the lamp, position the two pins above the holes in the lampholder;
- Gently push the lamp into the lampholder and remove the protective sleeve;
- Replace the light shield/spill ring and front bezel assembly, ensuring the thumbscrews are securely fastened.

Testing

Upon correct installation and connection to an electrical supply, the equipment can be tested in order to ensure its' correct performance. A competent person with some knowledge of electrical equipment must carry out this work.

Equipment required: Multi-meter with leads
 Ammeter

Using the equation $P=VI$, the approximate power output of the equipment can be calculated in the following way:

- Using the multi-meter, take a voltage reading;
- Using the ammeter, take an amps reading from the live cable to the lamp;
- Multiply these figures together to give an approximate wattage (Power output).

For example:

Using a 240v 1000w Tungsten halogen lamp:
Voltage reading = 240v; Amps reading = 4 amps

Therefore, Wattage = $240 \times 4 = 960$ watts

7- Fault Finding

All fault finding must be conducted by a competent person or qualified Electrical Engineer.

Failure of Lamp to light

Causes:

- 1) Power not supplied;
- 2) Fuse blown;
- 3) Failed lamp

Remedy:

- 1) Check voltage at supply. If supply is not present the fault is at the customer supply. If power is present, see remedy 2;
- 2) Check fuse for visual failure. If none noticeable check fuse for continuity using a multi-meter. If fuse found to be faulty, replace with new part and test equipment again for correct working order. If found to be working correctly see remedy 3;
- 3) Firstly, check supply at lampholder connecting block (within searchlight barrel). If supply is present, disconnect unit from power supply before removing the lamp. If noticeable damage to filament is present, the lamp will have failed. The lamp can also be checked for continuity using a multi-meter. Replace lamp ensuring all precautions and instructions previously outlined in this manual are adhered to.

Failure of Remote Focus

Causes:

- 1) Power not supplied;
- 2) Faulty connections;
- 3) Failed motor/transformer

Remedy:

- 1) Check voltage at supply. If no supply present fault is at customer supply. If power is present see remedy 2;
- 2) Check all wiring connections on motor, transformer and terminal rail, in accordance with the wiring diagram. If found to be correct, see remedy 3;
- 3) Remove focus motor and apply 24v DC directly across terminals. If motor does not rotate the unit has failed. A new focus motor should be fitted to the lampholder assembly. If the motor is working correctly, check output of transformer (mounted in the Motor Gearbox).

NOTE: If a fault occurs on the pan and tilt gearbox, the unit should be returned to Francis Searchlights Limited for fault evaluation and repair.

8 - Maintenance and Servicing

In order to prolong the service life and performance of your searchlight, the following maintenance guidelines are recommended:

- Maintenance checks should be conducted before every voyage or at least every three months;
- Before checking, disconnect the equipment from the supply;
- Visually inspect the condition of the equipment;
- Any major or minor structural damage should be rectified immediately in order to reduce sympathetic wear;
- After inspection it may be necessary to clean the inside of the searchlight. The following procedure should be adhered to:
 - Remove the front bezel;
 - Clean the front glass inside and out using a proprietary glass cleaner or metal polish;
 - Clean the reflector if required;
 - Check the reflector mounting gaskets. If signs of corrosion or damage are evident, replace as necessary;
 - Ensure that the lampholder is free from corrosion or other damage;
 - Check earthing point for conductivity;
- It is advisable to check all seals and gaskets for signs of degradation. Renew if necessary;
- The searchlight is fitted with a breather unit. This ensures a steady airflow in order to prevent any vacuum forming within the barrel.
- Upon completing all maintenance requirements the searchlight should be tested for full working order (approximately 20 minutes).

If in any doubt as to the correct servicing procedures to adopt please contact your distributor/agent or the manufacturer who will be able to advise the best course of action for your product.

9 - Wiring Diagrams and General Assembly

Drawing Number	Description
A2542	FR380RC Explorer H.V G.A
A2541	FR380RC Explorer L.V G.A
C23293	H.V Explorer RC Wiring Diagram
C23291	L.V Explorer RC Wiring Diagram
C22848	High Voltage Control Panel
C22431	Low Voltage Control Panel
C23603	Junction Box Assembly

ITEM	PART No.	DRG No.	DESCRIPTION	QTY	DATE	BY	REVISIONS
1	C17218	X4980	BARREL ASSY H.V	1	AS FIRST DRAWN	2/02	
2	C23247	C23247	H.V MOTOR UNIT ASSY	1	C1924 HAS REPLACES FOR C12415 (EC1179)	2/02	
3	C23912	C23912	U-PIECE ASSY	1	C24009 ADDED 3.00 DIA. (EC1285)	2/02	
4	C22914	C22914	CRUTCH S/ASSY	1			
5	C20270	C20270	BELLOW TOP BUSH	1			
6	C20281	C20281	BELLOWS	1			
7	C10109	X2844	TRUNNION SPACER	2			
8	C23350	C23350	U-PIECE BUSH	2			
9	C23281		CONDUIT GLAND M20	2			
10	C23280		CONDUIT G20 1M	2			
11	C10158		GLAND M20	2			
12	C20943		LIFTING HANDLE	2			
13	C21967		1/2 RING	1			
14	C23527		SEALING WASHER M20	1			
15	C16693		CABLE 3M 4 CORE 1.5mm	1			
16	C20241		CABLE 3M 12 CORE 0.5mm	1			
17	C13873		CABLE 3M 1.5mm BLACK	2			
18	C13872		CABLE 3M 1.5mm RED	3			
19	C1512		CABLE 3M 1.5mm G/YEL	1			
20	C08369		SCREW M12 x 20 HEX HD	4			
21	C09208		SCREW M8 x 30 HEX HD	2			
22	C10174		SCREW M6 x 20 PAN HD	2			
23	C08370		WASHER M12 FLAIN	5			
24	C12133		WASHER M12 S/C SPRING	2			
25	C08989		WASHER M8 FLAIN	3			
26	C15041		WASHER M8 S/C SPRING	2			
27	C08987		WASHER M6 FLAIN	2			
28	C12354		NUT M8 NYLOCK	1			
29	C24009	C24009	PUSH ROD TOP BUSH	1			

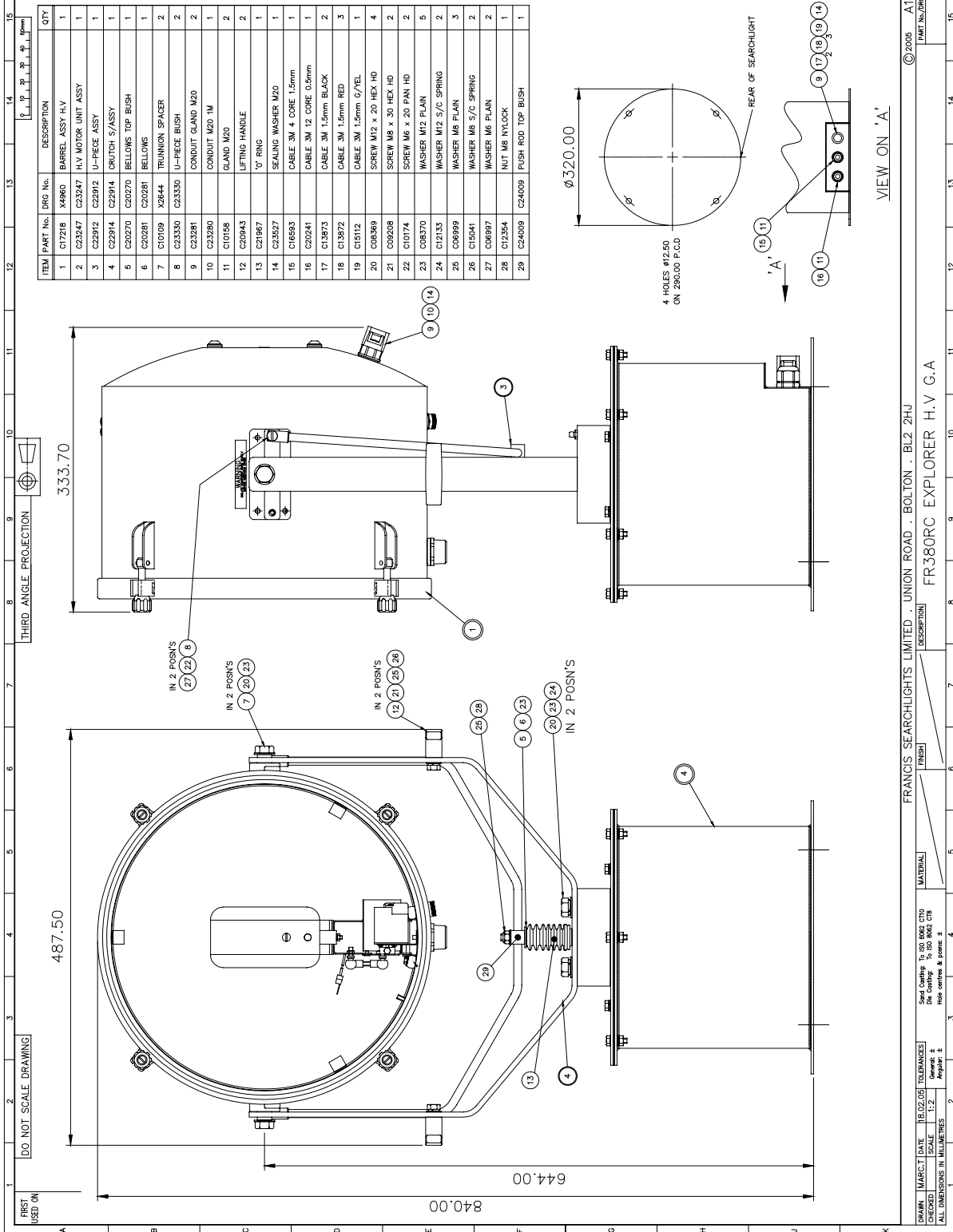

FRANCIS SEARCHLIGHTS LIMITED . UNION ROAD . BOLTON . BL2 2HU	FRANCIS SEARCHLIGHTS LIMITED	UNION ROAD	BOLTON	BL2 2HU
FR380RC EXPLORER H.V G.A	DESCRIPTION			
	FINISH			
	MATERIAL			
	Scale: Drawing 1:50 8002 STD			
	Shop Drawing 1:50 8002 STD			
	Check Drawing 1:50 8002 STD			
	Approval 2			
	Approval 3			
	Approval 4			
	Approval 5			
	Approval 6			
	Approval 7			
	Approval 8			
	Approval 9			
	Approval 10			
	Approval 11			
	Approval 12			
	Approval 13			
	Approval 14			
	Approval 15			
	Approval 16			
	Approval 17			
	Approval 18			
	Approval 19			
	Approval 20			
	Approval 21			
	Approval 22			
	Approval 23			
	Approval 24			
	Approval 25			
	Approval 26			
	Approval 27			
	Approval 28			
	Approval 29			
	Approval 30			
	Approval 31			
	Approval 32			
	Approval 33			
	Approval 34			
	Approval 35			
	Approval 36			
	Approval 37			
	Approval 38			
	Approval 39			
	Approval 40			
	Approval 41			
	Approval 42			
	Approval 43			
	Approval 44			
	Approval 45			
	Approval 46			
	Approval 47			
	Approval 48			
	Approval 49			
	Approval 50			
	Approval 51			
	Approval 52			
	Approval 53			
	Approval 54			
	Approval 55			
	Approval 56			
	Approval 57			
	Approval 58			
	Approval 59			
	Approval 60			
	Approval 61			
	Approval 62			
	Approval 63			
	Approval 64			
	Approval 65			
	Approval 66			
	Approval 67			
	Approval 68			
	Approval 69			
	Approval 70			
	Approval 71			
	Approval 72			
	Approval 73			
	Approval 74			
	Approval 75			
	Approval 76			
	Approval 77			
	Approval 78			
	Approval 79			
	Approval 80			
	Approval 81			
	Approval 82			
	Approval 83			
	Approval 84			
	Approval 85			
	Approval 86			
	Approval 87			
	Approval 88			
	Approval 89			
	Approval 90			
	Approval 91			
	Approval 92			
	Approval 93			
	Approval 94			
	Approval 95			
	Approval 96			
	Approval 97			
	Approval 98			
	Approval 99			
	Approval 100			

STANDARD PRACTICE
Refer to our associated website
for further details.

© 2006 FRANCIS SEARCHLIGHTS LIMITED

FRANCIS SEARCHLIGHTS LIMITED

UNION ROAD . BOLTON . BL2 2HU

FR380RC EXPLORER H.V G.A

DESCRIPTION

FINISH

MATERIAL

Scale: Drawing 1:50 8002 STD

Shop Drawing 1:50 8002 STD

Check Drawing 1:50 8002 STD

Approval 2

Approval 3

Approval 4

Approval 5

Approval 6

ITEM	PART No.	DRG No.	DESCRIPTION	QTY
1	C20007	C20007	BARREL ASSY LV	1
2	C23248	C23248	H.V MOTOR UNIT ASSY	1
3	C22912	C22912	U-PIECE ASSY	1
4	C22914	C22914	CRUTCH S/ASSY	1
5	C20270	C20270	BELLOWS TOP BUSH	1
6	C20281	C20281	BELLOWS	1
7	C10109	X2644	TRAINING SPACER	2
8	C23350	C23350	U-PIECE BUSH	2
9	C23281		CONDUIT GLAND M20	2
10	C23280		CONDUIT M20 IM	1
11	C10158		GLAND M20	2
12	C20943		LIFTING HANDLE	2
13	C21967		O' RING	1
14	C23527		SEALING WASHER M20	1
15	C16583		CABLE 3M 4 CORE 1.5mm	1
16	C20241		CABLE 3M 12 CORE 0.5mm	1
17	C13873		CABLE 3M 1.5mm BLACK	2
18	C13872		CABLE 3M 1.5mm RED	3
19	C15112		CABLE 3M 1.5mm G/YEL	1
20	C08369		SCREW M12 x 20 HEX HD	4
21	C08208		SCREW M6 x 30 HEX HD	2
22	C10174		SCREW M6 x 20 PAN HD	2
23	C08370		WASHER M12 FLAIN	5
24	C12133		WASHER M12 S/C SPRING	2
25	C08989		WASHER M6 PLAIN	3
26	C10041		WASHER M6 S/C SPRING	2
27	C08987		WASHER M6 PLAIN	2
28	C12354		NUT M6 NYLOCK	1
29	C24009	C24009	PUSH ROD TOP BUSH	1

NO	REVISION DETAILS	DATE
1	AS PER DRAWING	2005
2	CHANGED TO NEW L.V. A	2005
3	C24009 ADDED 3.09 U.S.	2005

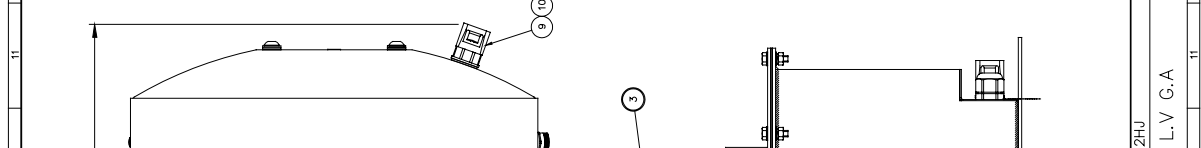
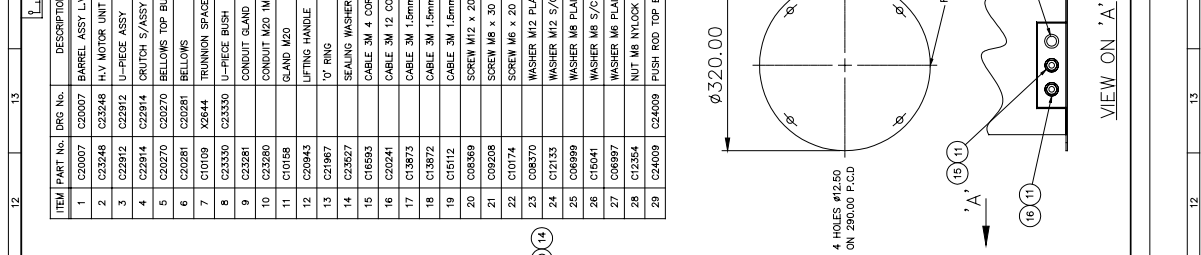

FINISH	TOLERANCES	SCALE	DATE
AS SHOWN	±0.10	1:2	15/02/05

FRANCIS SEARCHLIGHTS LIMITED . UNION ROAD . BOLTON . BL2 2HU
FR380RC EXPLORER L.V G.A

DRWING	MARK.	DATE	SCALE	TOLERANCES	FINISH	DESCRIPTION
1	1	15/02/05	1:2	±0.10	AS SHOWN	FR380RC EXPLORER L.V G.A

STANDARD PRACTICE	DATE
DEFINITION OF FINISHES	2005

FRANCIS	SEARCHLIGHTS
---------	--------------

© 2005	A1	CONT ON SHEET
--------	----	---------------

PART No./REV No.	QTY
A2541	1

SHIT

ALL DIMENSIONS IN MILLIMETRES

STAND OFF

STAND OFF

STAND OFF

STAND OFF

STAND OFF

STAND OFF

STAND OFF

STAND OFF

STAND OFF

STAND OFF

STAND OFF

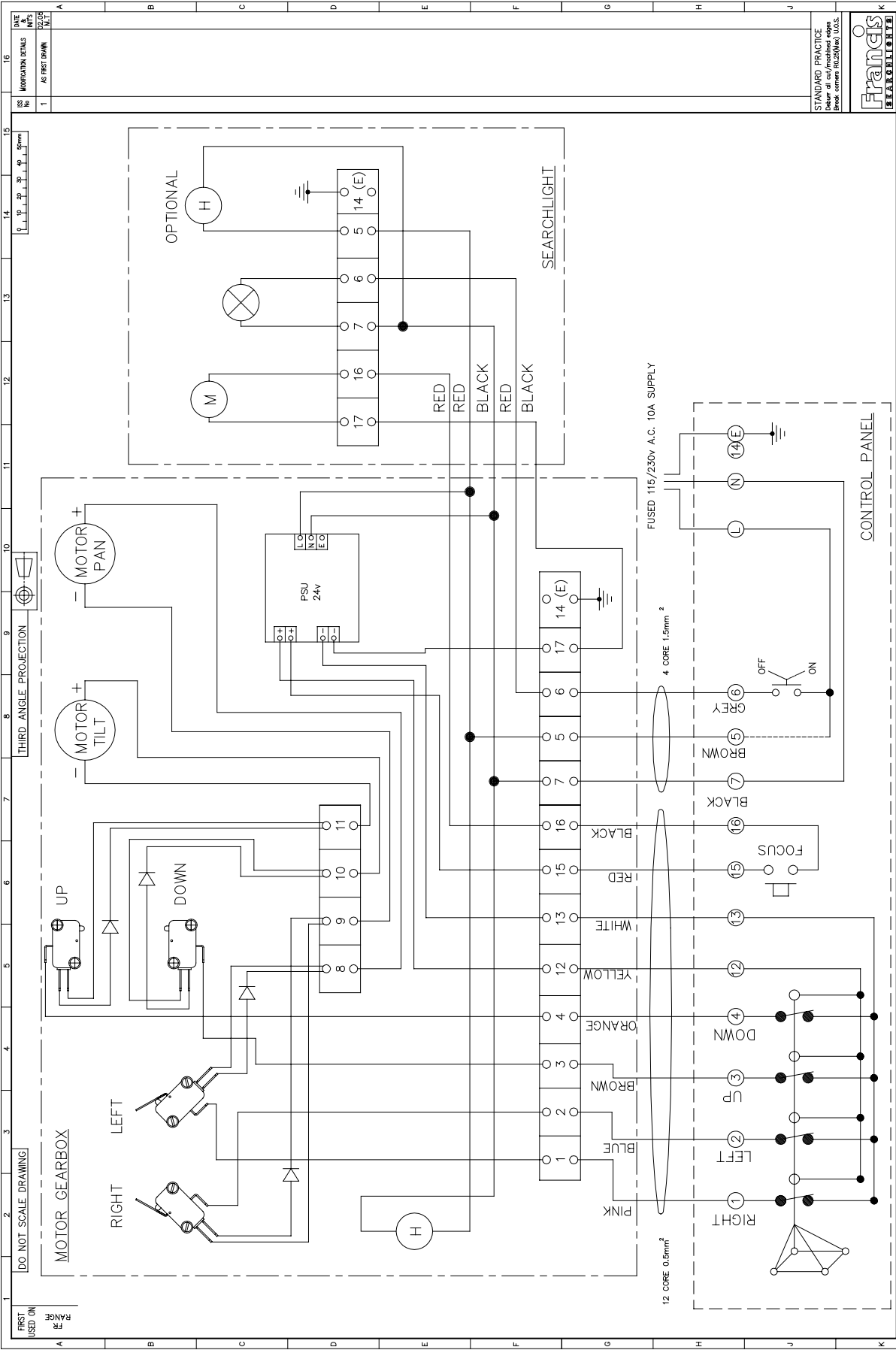

DATE	16
BY	
MODIFICATION DETAILS	
NO	1
AS FIRST DRAWN	

STANDARD PRACTICE
 Devoir à coté/à machine edge
 Break corners R25/R30/US3



© 2005	A1 CONT ON SHEET
PART No./REV. No.	
SHEET	C23293 1

FRANCIS SEARCHLIGHTS LIMITED · UNION ROAD · BOLTON · BL2 2HU

DESCRIPTION: WIRING DIAGRAM H.V RF EXPLORER

FINISH: []

MATERIAL: []

Scale: 1:1

Drawn: []

Checked: []

Approved: []

Notes: See Centre to ISO 8002 CTD
 Dim Centre to ISO 8002 C78
 Hole centres & pitch: ±

DO NOT SCALE DRAWING

THIRD ANGLE PROJECTION

16 15 14 13 12 11 10 9 8 7 6 5 4 3 2 1

A B C D E F G H J K

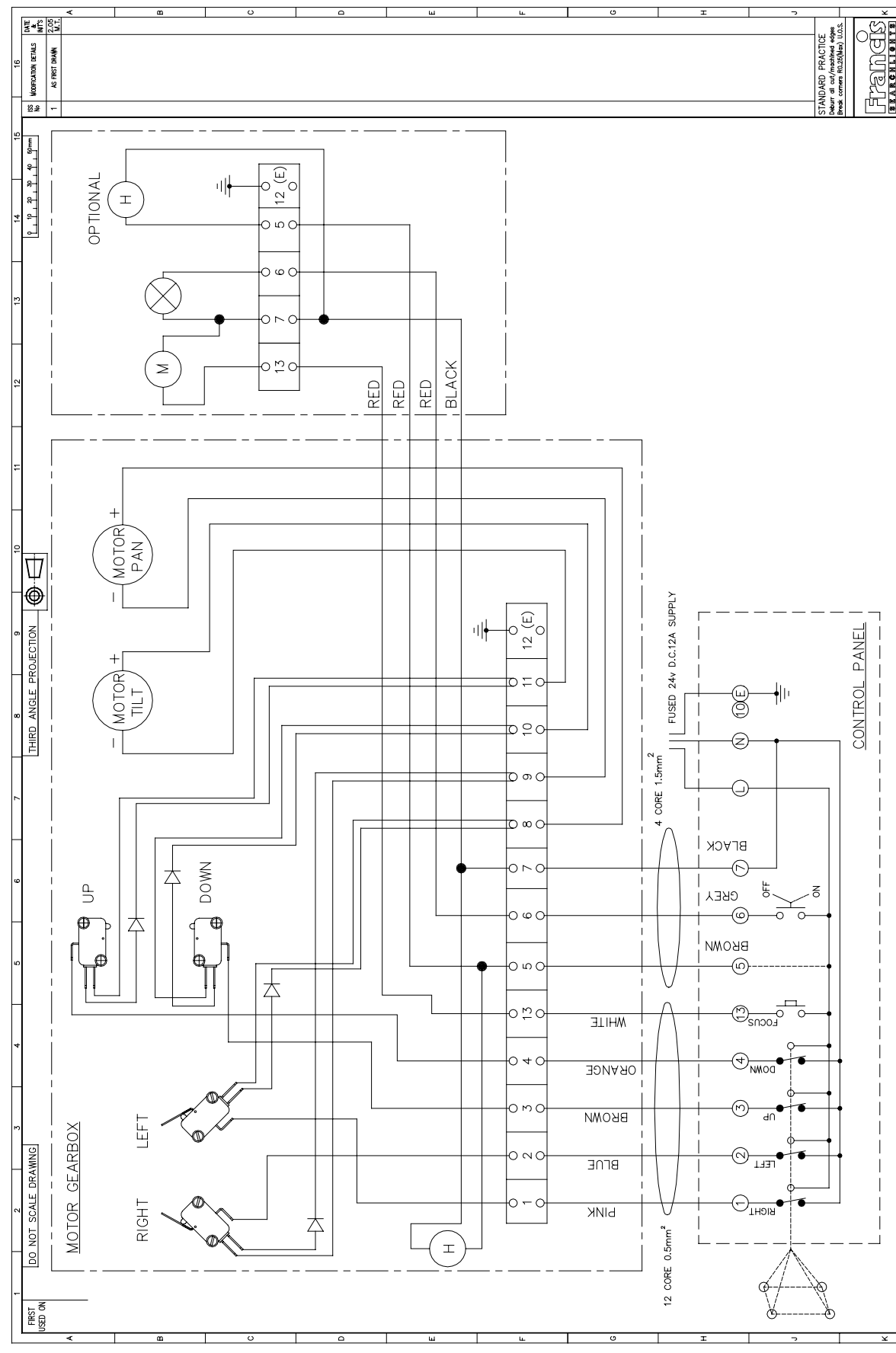

DATE: 07/02/08
 DRAWN: M.A.R.C. I.
 CHECKED: S.C.A.L.E.
 ALL DIMENSIONS IN MILLIMETRES

DO NOT SCALE DRAWING
 THIRD ANGLE PROJECTION
 1:1
 0 10 20 30 40 50mm

STANDARD PRACTICE
 Detail of cut/machined edges
 Drawn corner fillet (R0.5) U.S.S.

© 2006 A1 CONT ON SHEET
 PART No. (ORG. No.) C23291
 SHIT 1

FRANCIS SEARCHLIGHTS LIMITED · UNION ROAD · BOLTON · BL2 2HJ
 MATERIAL: ENGLISH
 DESCRIPTION: WIRING DIAGRAM L.V RF EXPLORER

DRAWN: M.A.R.C. I. DATE: 07/02/08 TOLERANCES: Send Conting. To ISO 8002 C710 Die Conting. To ISO 8002 C78
 CHECKED: S.C.A.L.E. SCALE: General: ± 10% Hole centres & points: ± 0.1
 ALL DIMENSIONS IN MILLIMETRES

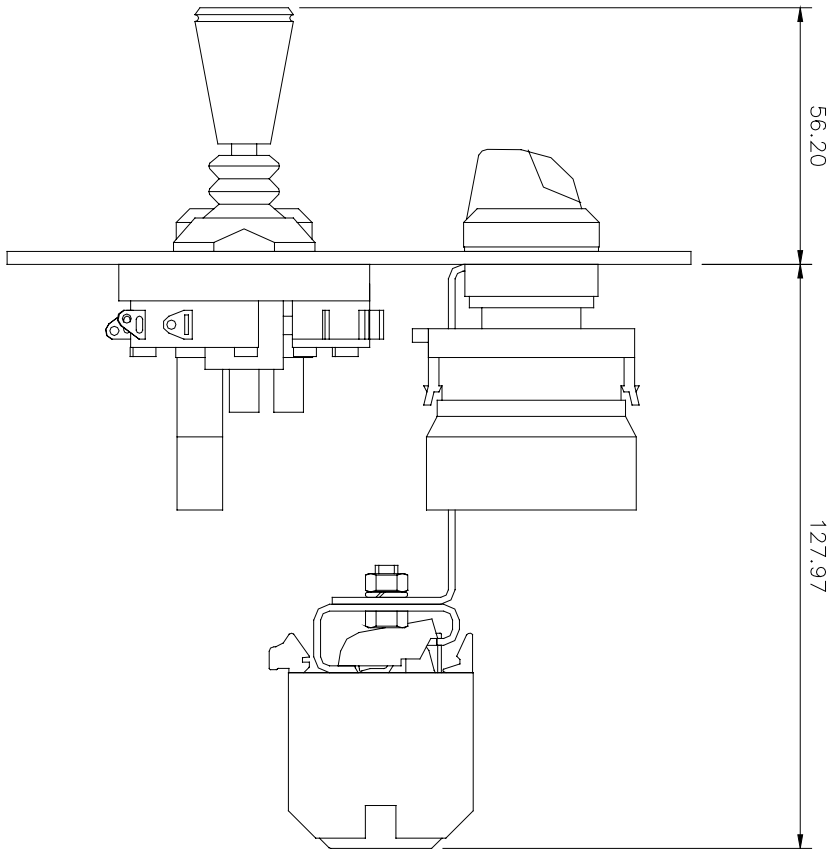
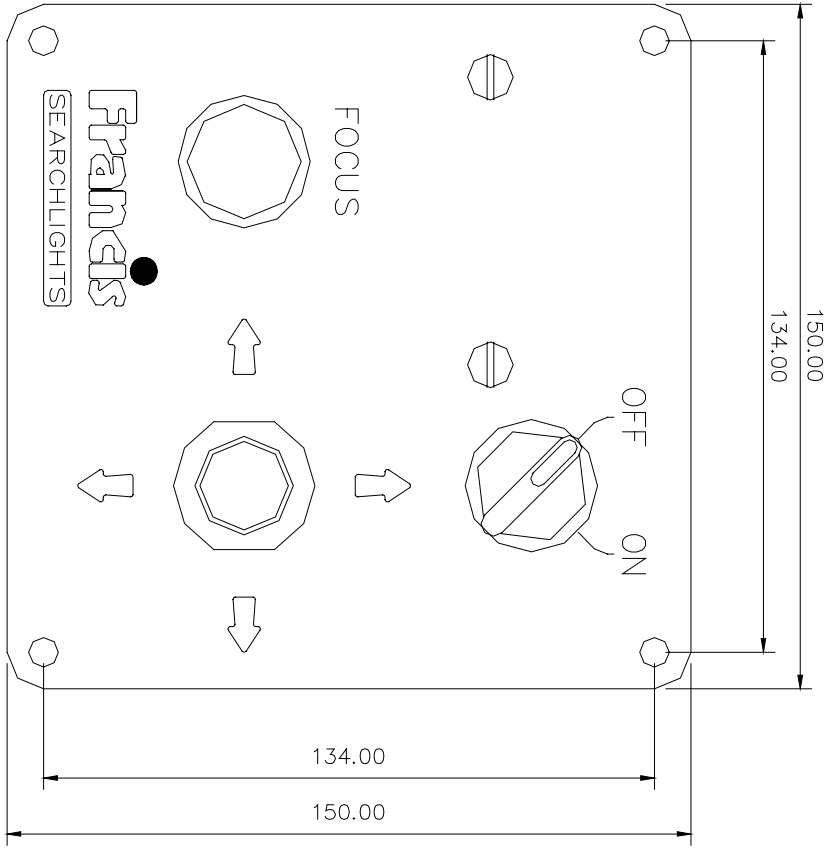

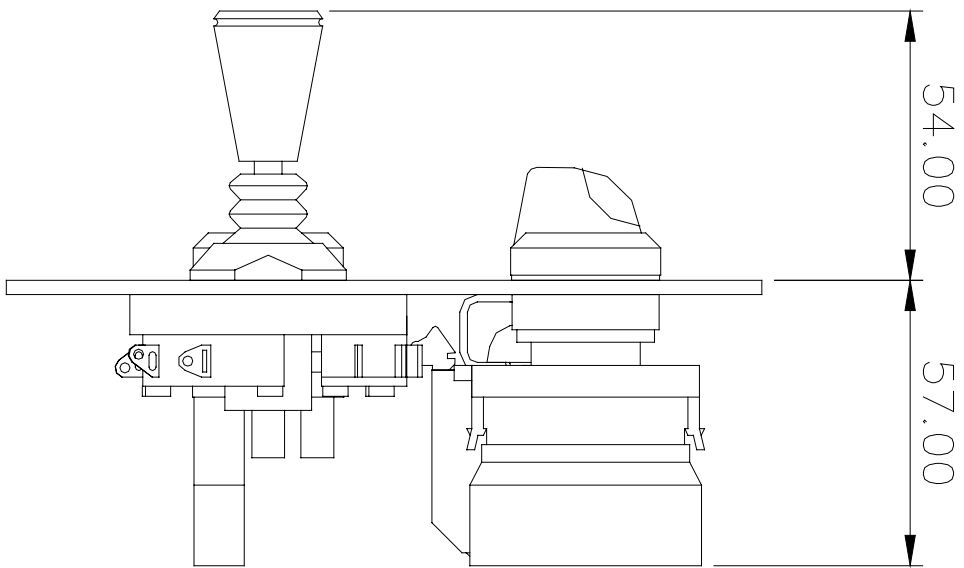
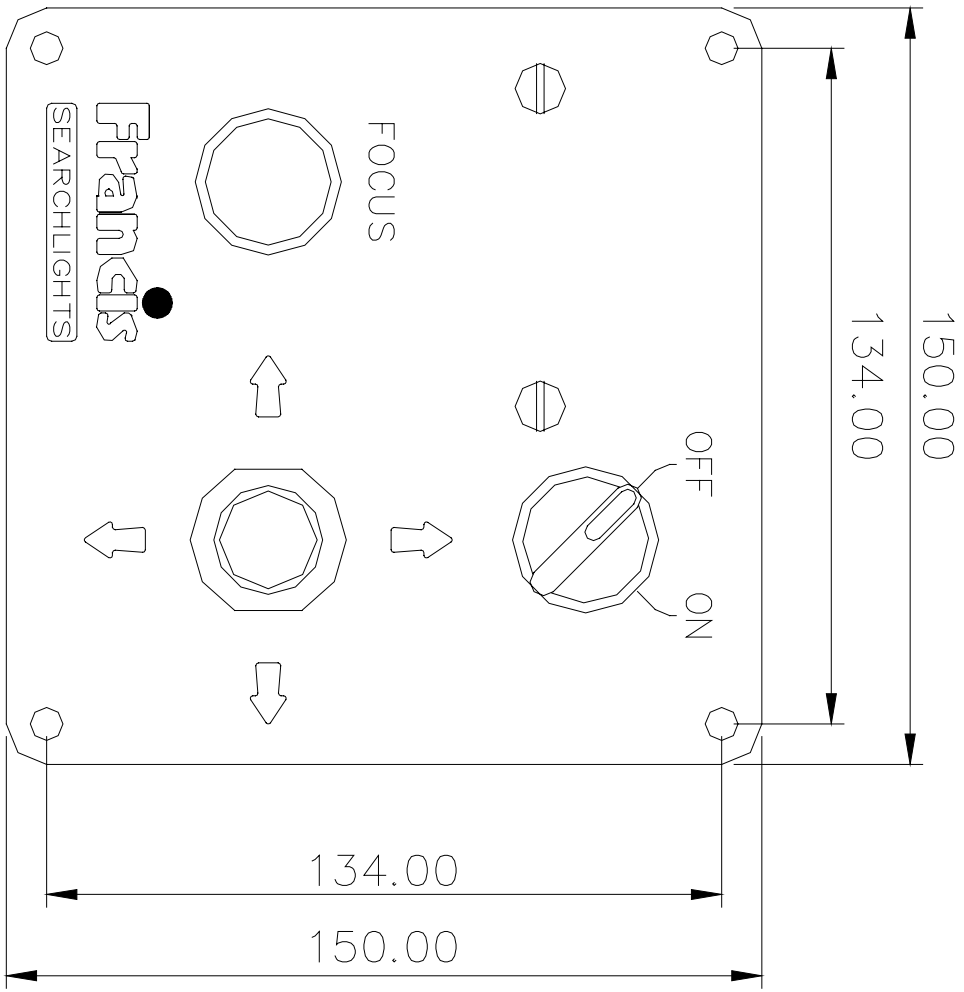

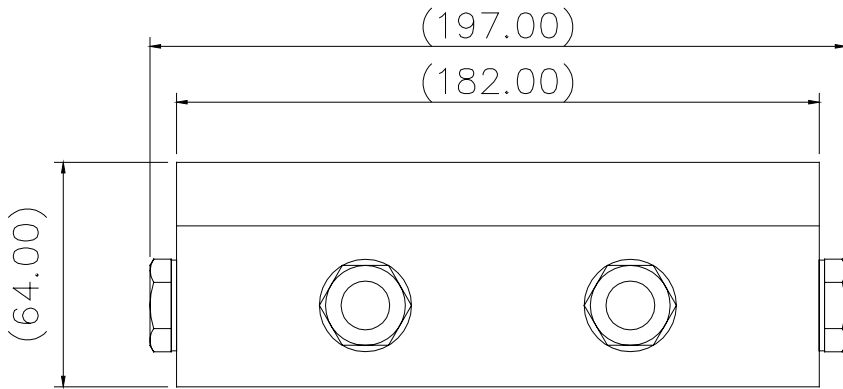
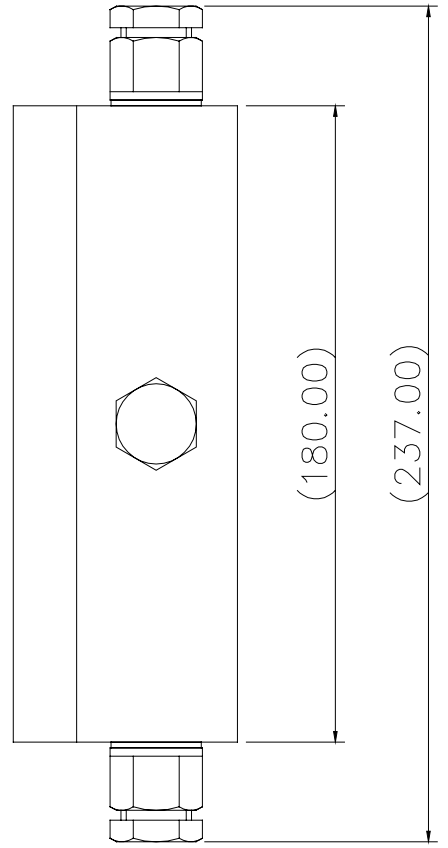
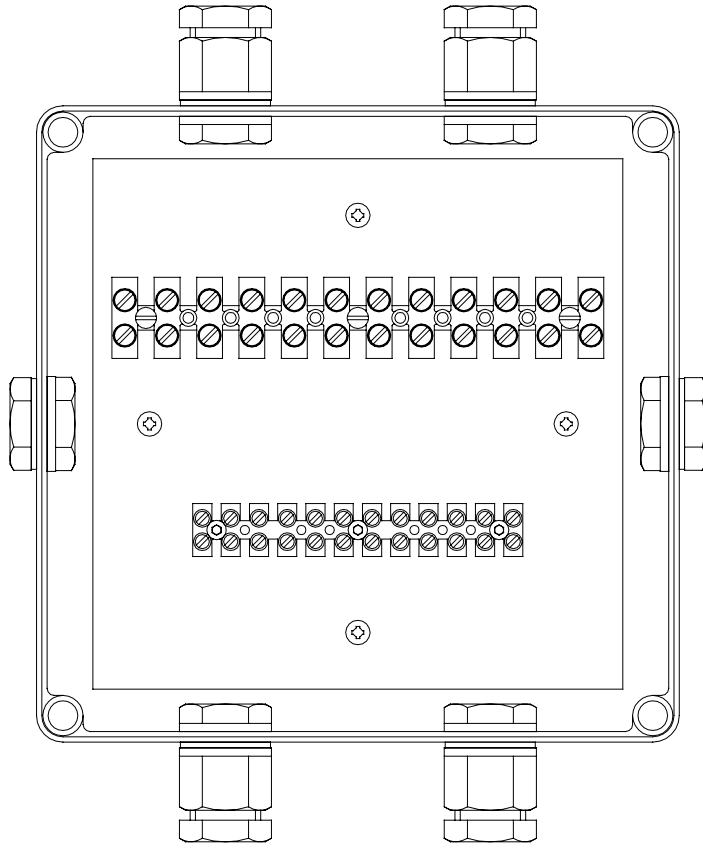

[Back To Top](#)

10 - Spare Parts List

The following spare parts can be ordered directly from the manufacturer:

Part Number	Description
Searchlight Spares	
D14795	24v 150w 300HRS GX6.35 Tungsten Halogen Lamp
D4695	24v 250w 2000HRS GX6.35 Tungsten Halogen Lamp
D9851	24v 250w 300HRS GX6.35 Tungsten Halogen Lamp
D1809	115v 1Kw GX9.5 Tungsten Halogen Lamp
D6715	220v 1Kw GX9.5 Tungsten Halogen Lamp
D1813	220v 650w GX9.5 Tungsten Halogen Lamp
C16878-00	Lampholder GX6.35
C03022-00	Lampholder GX9.5 1Kw
C14143-00	Switch 10A - On/Off
C14142-00	Switch – Focus
C08919-00	Front Glass
C08920-00	Front Glass Gasket
C16410-00	Motor - Remote Focus
C08885-00	Reflector
C20070-00	Drainage Plug
C22268-01	Breather Assy
C16761-00	A.V. Mount
C20281-00	Bellows
Motor Gearbox Spares	
C23259-01	Pan Motor Assy
C23267-01	Tilt Motor Assy
C22380-00	Microswitch no lever
C22382-00	Microswitch with lever
C23234-00	Pedestal Sealing Gasket
C23530-00	P.S.U

In order to prolong the life and performance of your product, we recommend that you only specify Francis Searchlights spare parts. This will ensure that any warranties on your equipment will not be invalidated.

When ordering spare parts please contact the Sales Department at Francis Searchlights Limited. Please quote searchlight model and serial number at all times. This will enable a fast response to your spares' requirements.

[Back To Top](#)