



## User Instruction & Installation Manual

### LX480 Remote Control 1 Kilowatt Xenon Searchlight



#### Product Reference Number:

**A2489 – Variable Speed Motor Unit 240v**

**A2492 – Variable Speed Motor Unit 115v**

#### *Manufacturers details:*

Francis Searchlights Ltd  
Union Road, Bolton  
Lancashire, BL2 2HJ, UK  
Tel: +44 (0) 1204 558960  
Fax: +44 (0) 1204 558979  
<http://www.francis.co.uk>  
E-mail: [sales@francis.co.uk](mailto:sales@francis.co.uk)

#### *Distributor details:*



Manual Part Number: C21809

23.11.11 Issue : 16

# CONTENTS

- 1 - Introduction
- 2 - Safety Precautions
- 3 - Technical Information
- 4 - Unpacking and Installation Instructions
- 5 - Electrical Installation
- 6 - Operating Instructions
- 7 - Fault Finding
- 8 - Maintenance and Servicing
- 9 - Wiring Diagram & General Assembly
- 10 - Spare Parts List

# 1 – Introduction

**It is imperative that this manual is read carefully and understood before installing your equipment. For your future reference please keep this manual in a safe place.**

Thank you for specifying a product from the Francis Searchlights range. All Francis products are designed to give complete customer satisfaction and are manufactured to the highest engineering standards in order to ensure optimum performance and service life.

The Francis Xenon range combine features proven over many years service in the most hazardous conditions in both marine and land installations.

In order to prolong the life and performance of your product, we recommend that you only specify Francis Searchlights spare parts. This will also ensure that any warranties on your equipment will not be invalidated. Information on spares ordering and parts is provided in this manual.

Should you ever need to contact Francis Searchlights Ltd. regarding your equipment, please quote the Product Serial Number at all times.

## 2 - Safety Precautions

The following instructions must be adhered to, in order to ensure a safe working environment and the safety of the user.

**Note: When unpacking or manoeuvring the searchlight into its fixing position, suitable lifting points must be used in order to prevent damage to the equipment or personal injury.**

- Because of the high internal pressure within the lamp, there is a risk of explosion in either a hot or cold state;
- During operation this lamp emits intense UV radiation which is harmful to the eyes and skin. Suitable protection should be worn;
- The high luminance of the arc can cause severe damage to the eye if viewed directly. ALWAYS wear suitable protective goggles when viewing the lamp;
- Always use protective jackets supplied with the lamp;
- Should it be necessary to examine the lamp with the front bezel removed, always use a protective shield and wear goggles to ensure a safe working environment;
- Searchlights get hot. Never touch the unit when lit and always allow 15 to 20 minutes for cooling down after turning the searchlight off;
- Never place anything on or cover the searchlight when in use;
- Ensure the lamp has cooled sufficiently before removal;
- If undue force appears necessary to remove the lamp, the equipment should be inspected by a competent person or contact the manufacturer;
- When disposing of lamps there are several options available:
  - Return the lamp, via the supplier, to the lamp manufacturer in its complete packaging
  - Because of the cold internal pressure of the lamp is approximately 8 bar, the lamp must first be depressurised before disposal. Place the lamp, in its protective jacket, in a plastic bag and drop from a height of 1 to 2 metres onto a hard surface;
- XBO lamps do not contain materials which are harmful to the environment and thus are not subject to special waste disposal regulations;
- Due to the vast range of lamps available it may appear possible that more powerful lamps can be used in the equipment than for which it was designed. Even when the unit will physically accept a higher wattage lamp, this substitution is not recommended and is dangerous. This action will also void any warranties on the equipment.
- Always refer to the lamp manufacturers technical data when dealing with lamps.

### 3 - Technical Information

This product has been designed to operate in accordance with the product specification. The LX480RC 1000 watt searchlight has the following features:

- All marine grade materials and fixings;
- Electronic power supply unit;
- Parabolic glass reflector;
- Stove enamel painted;
- 385° horizontal rotation;
- Vertical movement 25° to -25°;
- Motor speed 20°/sec fast, 10°/sec slow (Pan).  
0-10°/sec fast, 0-5° slow (Tilt);
- Remote focus facility;
- Internal self-regulating heater.

The searchlight also performs to the following optical data:

- Xenon light source;
- Lamp Wattage - 1000 Watts;
- Supply voltage – 208v-253v or 100v-132v;
- Peak Beam Candlepower – 67,779,546 lux;
- Range – 8,233 metres;
- Divergence - 1.5° to 10°;
- Temperature range: -50°C;

In order that the searchlight operates correctly it is imperative that competent personnel are responsible for the installation, operation and servicing of this equipment. Failure to adhere to this advice may cause premature failure or incorrect operation of the searchlight, which may damage the equipment or cause personal injury.

Technical information on the Irem Power Supply Unit and Ignitor are included overleaf. For more detailed information please contact the manufacturer.

PSU ref.: PX-50 N  
Ignitor ref. AS16040A

Power Supply fixing centres 450 x 180 using M6 screws.

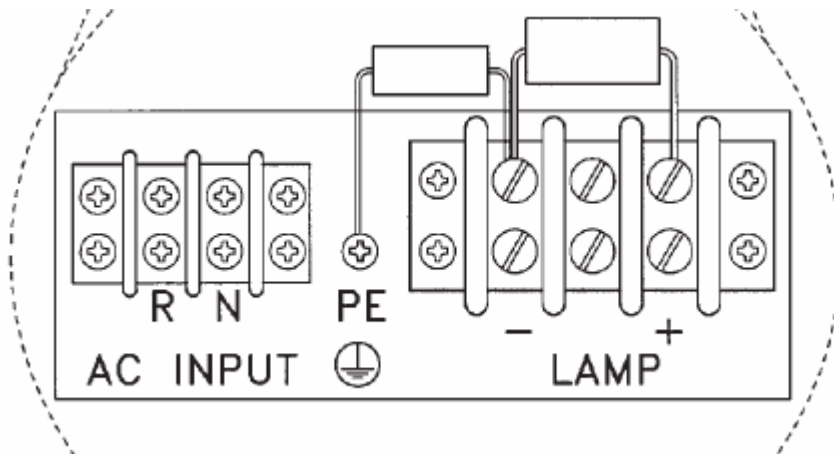

R = Live      N = Neutral      PE = Earth      Lamp - + = DC Output

Model	Lamp power [W] (approx.)	Max. input current [A]	AC input voltage/frequency [V - Hz]	AC input voltage range [V]	DC current range [A]	DC output voltage range [V]	No-load voltage range [V]	Pk to pk current ripple
PX-40N	700	10	230 - 50	208 - 253	36 - 45	16 - 22	125 - 170	<6%
	700	10	220 - 60	208 - 230	36 - 45	16 - 22	125 - 170	<6%
PX-50N	1000	11	230 - 50	208 - 253	30 - 50	20 - 25	120 - 170	<6%
	1000	11	220 - 60	208 - 230	30 - 50	20 - 25	120 - 170	<6%
PX-50N	1000	23	110 - 60	100 - 132	30 - 50	20 - 25	120 - 170	<6%

Marking: CE  
 Operating temperature: 0°C to 40°C  
 Storage temperature: -20°C to +60°C  
 Cooling: free convection  
 Degree of protection: IP20  
 Efficiency: >0.8

### Outline drawing

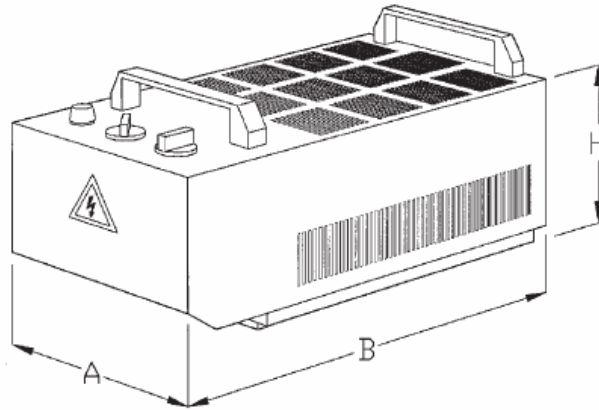

Model	Dimensions [mm]			Weight [kg]
	A	B	H	
PX mod.	245	595	238	56

# AS series

## Introduction

These igniters are expressly designed to strike Xenon, Xenon-Mercury, Mercury, Metal Halide and similar arc lamps. They produce the high voltage, high frequency starting potential required to get the gas in the lamp to ionize and make the current flow possible.

The **AS** igniters meet the lamp manufacturers' recommendations to ensure immediate and correct ignition of the lamp when cold or in any cooling stage.

They should be installed close to the lamp (but thermally shielded from it); the high voltage lead must be as short as possible and carefully insulated to prevent corona loss and reduction of strike energy. The ambient temperature must not exceed 60°C.

Some models are equipped with a built-in special function relay allowing automatically cycled or timed ignition. Also this relay prevents the igniter from striking when the lamp is ON or if the no-load voltage to the lamp is not correct. As far as the insulation class, this device can be considered Cl. II (as per IEC 536), but it must be grounded for interference suppression.

## Block diagram

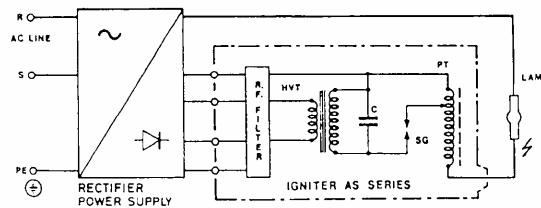

## Outline drawing

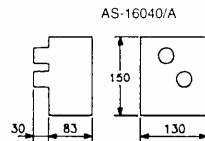
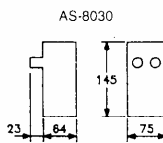
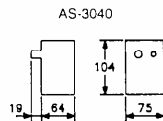

## AS Series range

Models	AC input (50-60Hz)		H.V. output KV	Lamp current A	Weight Kg.
	Volt	A during ignition			
<b>AS-3040</b>	230V	0.8	40	30	1.3
<b>AS-8030</b>	±10%	1.5	30	80	1.5
<b>AS-16040A</b>		3.8	40	160	3.5

The suffix 'A', used for the model AS-16040A, means that it has a built-in relay system for automatic or short timed ignition.

## 4 - Unpacking and Installation Instructions

The following instructions should be read and fully understood prior to installing the equipment to ensure that the correct procedures are followed and all safety precautions are observed.

**Note: If the equipment has been in storage for a considerable amount of time, it is advisable to conduct a routine maintenance check on all parts before installation.**

### Safety Precautions

This equipment should not be connected to an electrical supply before being installed. Installation procedures should be adhered to in order to ensure a safe working environment and reduce the risk of damage or personal injury.

### Preparing the Mounting Position

Mark out and drill the fixing holes through the deck and bolt the searchlight base securely. On an uneven surface it is necessary to use a suitable sealant, such as silicone, in order to ensure a weatherproofed joint. If anti-vibration mounts are to be fitted, the fixing holes for the mounts should also be marked out and drilled. Prior to manoeuvring the searchlight into its' fixing position, the AV mounts should be fitted to the base. When in the desired position, bolt the searchlight firmly down.



## 5 - Electrical Installation

For safety purposes, only competent personnel should perform the electrical installation. All equipment should be installed to current Electrical Regulations and Standards.

In order to obtain the maximum light output from the searchlight, it is essential that the full operating voltage of the lamp fitted be applied to the lampholder contacts.

### Method of Electrical Connection

- 1) Disconnect the supply before working on the electrical system;
- 2) The searchlight must be connected to a fused electrical supply, using suitably sized cable;
- 3) If the searchlight is located a considerable distance from the supply, provision must be made in the cable size in order to overcome the voltage drop.

**The PSU should NOT be positioned no more than 5 meters away from the searchlight.**

The following table below indicates the maximum length of cable to be used for the AC supply cable, from the control panel to the searchlight:

Searchlight	115v 1Kw	240v 1Kw
Cable Size (mm <sup>2</sup> )	Distance Max	Distance Max
1.5	17 MTRS	75 MTRS
2.5	28 MTRS	123 MTRS
4	44 MTRS	195 MTRS
6	68 MTRS	304 MTRS
10	115 MTRS	509 MTRS

- 4) Whenever possible cable terminations should be made below deck and with approved terminal devices;
- 5) If a spare auxiliary fuse or circuit breaker is not available, one of the correct type and rating should be fitted and connected to a positive supply. It is advisable to locate a bus bar or main connection and avoid any direct connection to the supply;
- 6) For 110/220v AC products, the following colour coding system should be used for the customer supply cable:

Brown            - Live  
Blue             - Negative  
Green/Yellow   - Earth

**Note: This equipment must be earthed.**

## Installation Guidelines

A typical installation and connection routine for the searchlight is as follows:

Referring to wiring diagram C22462, a supply is fed to the control panel, which then provides a common feed to the motor gearbox, Power Supply Unit and the searchlight control panel.

The searchlight has been pre-wired with 3 meters of cable from the gearbox to junction box provided.

Cables required to be connected by the customer: -

4 core 4.0mm cable from the Junction Box into the PSU, doubling up the pairs,

3 core 1.5mm cable from the Junction Box into the PSU,

4 core 1.5mm cable from the Junction Box to the Control Panel.

12 core 0.5mm cable from the Junction Box to the Control Panel.

3 core 1.5mm cable from the PSU to the Control Panel (terminals 6 & 7) & the Mains cable to the Control Panel both to be supplied by the customer.

### Optional Slave Panel Wiring

8 core 0.5mm<sup>2</sup> cable from the Slave Panel to the Junction Box.

The searchlight head is pre-wired along with the connecting cable to the motor gearbox.

When the light is in operation, the output from the PSU should be approximately 19v dc at 50amps.

### Basic Operation

When the searchlight is switched on a 240v or 115v supply is fed to the PSU and linked to the ignitor. Also from the PSU, a dc output is fed to the lamp.

The ignitor ionises the gas within the lamp and this strikes the light.

All other facilities are fed via the control panels and motor gearbox.

### Notes for Use of Irem PSU

The Irem PSU used on the 1Kw searchlight has two external switches allowing 12 different output values. Upon installation of the searchlight, and connection to an electrical supply by a qualified Electrical Engineer, voltage and current readings should be taken to ensure that the lamp is operating at its' optimum values.

For guidance purposes, the switch settings should be set at 'LOW' and '4' prior to striking the lamp. Upon striking, the running wattage of the lamp can be calculated by using the equation:

$$P = VI$$

Where P= Power (watts)

V= Voltage (V)

I = Current (Amps)

Instruments required: D.C. Ammeter

Multimeter

## Procedure

- 1) With the multimeter, test the DC voltage in the searchlight head. This should be approximately 17/18 volts.
- 2) With the D.C ammeter, test the current of the red DC cable at front of searchlight. It should read approximately 55 to 60 amps.
- 3) Multiply these readings together, as shown above, to obtain the desired wattage required, usually about 960watts.

For example, if it is found that upon calculation the lamp is only running at 800watts, then alterations can be made by 'stepping up' the switch. Use the fine adjustments to obtain the correct operating characteristics for the lamp in order to ensure optimum life and performance. At each 'step up', the power should be re-calculated by following the above procedure until the ideal setting is achieved.

The 'LOW' and 'HIGH' setting on the Irem PSU allows large increases in output voltage, whereas the small steps 1 – 6 allow fine adjustment.

For information purposes, the values below were recorded at the FSL in order to provide customer guidance. Please note that these values were recorded with no load present:

Setting	DC Output (V)
Low & 1	92
Low & 2	98
Low & 3	102
Low & 4	106
Low & 5	111
Low & 6	115
High & 1	105
High & 2	112
High & 3	117
High & 4	123
High & 5	129
High & 6	135

### Notes:

- Always set output slightly below maximum power to ensure optimum lamp life and a safe working environment;
- Overrunning the lamp will severely effect the operation of the lamp and its' lifetime. Continuous operation in this mode is extremely hazardous and may cause the lamp to shatter.

## Fitting instructions for the 1Kw xenon lamp

Referring to the diagram overleaf:

- 1) Unfasten the eight latches (A) on the front and rear of the searchlight;
- 2) Remove the front bezel (B) and rear bezel (C) assemblies and carefully place to one side, ensuring no damage;
- 3) Unscrew the two M6 hexagon screws (D) from the front lampholder mounting block (E) and remove the front lampholder assembly from the mounting bracket;
- 4) Loosen the knurled screw on the front (F) lampholder assembly;
- 5) The lamp can now be inserted, make sure that the negative (cathode) end of the lamp is towards the rear of the searchlight and gently screw the end of the lamp into the rear lampholder socket. Do not overtighten and this may result in the lamp shattering due to undue force;
- 6) Fasten the front lampholder mounting block back in position, it will be necessary to pull the front socket against its spring to fit over the lamp. When in place tighten the front knurled screw (F);
- 7) Fasten the front and rear lampholder leads as wiring diagram, ensuring the connections are secure;
- 8) The front bezel and rear bezel can now be replaced. Ensure all latches are securely fastened down in order to provide effective waterproof seal;
- 9) Removal is the reverse of the above.

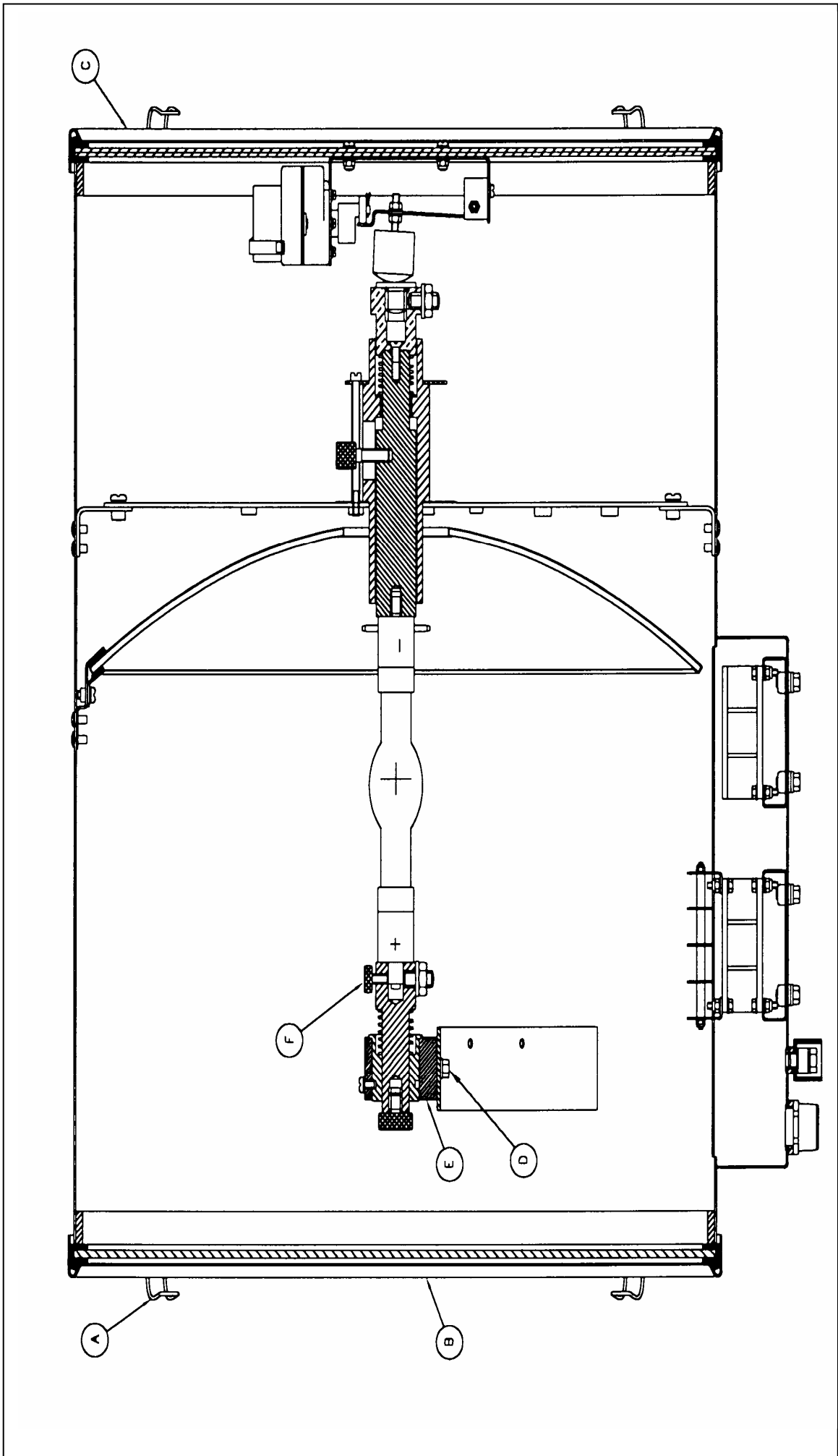

## 6 - Operating Instructions

This equipment is designed for use out of doors, in free air. Never place anything on, or cover the searchlight when in use as this may present a hazard.

The PSU should be housed below deck/in doors. Never leave the PSU exposed to weather conditions.

The searchlight can be remotely positioned via the joystick control panel, with the facility for movement up, down, left and right. The speed of movement depends on the more pressure applied to the joystick the faster the searchlight moves. When in the desired position the joystick should be released so that it returns to its' home position, dead centre.

The Variable Speed Gearbox has a fast and slow setting. You activate this by switching the controller switch on the control panel then selecting fast or slow.

The beam of the searchlight can be adjusted to give a variety of beam types. Using the yellow remote focus button on the joystick panel, the desired beam can be achieved for any particular application. The beam will move continuously through 'spot' to 'flood'. In order to fix the beam type; simply release the button at the desired position.

Please note that it is advisable to leave the heaters permanently in the 'on' position in order to remove condensation from the motor gearbox and searchlight head. The heaters specified on this equipment are self-regulating and will shut off when they reach the dew point temperature.

**This product should not be used for any purpose other than for which it was designed. Any modifications to the product should not be undertaken without consulting the manufacturer.**

## Setting to Work

Safe service in use necessitates the strict observance of the following precautions.

- Any article fabricated from quartz or glass is inherently fragile and care should therefore be taken, at all times, when handling lamps;
- Eye protection must be worn when handling lamps that have been removed from their packaging materials. The protective jacket should not be removed from the lamp for safety reasons, as there is a remote possibility of the lamp shattering violently, especially if it is subjected to mechanical shock or vibration;
- Ensure that the power rating of the Xenon lamp to be fitted is suitable for the lamphouse and power supply equipment (rectifier);
- Always isolate the equipment from the supply before inserting a lamp;
- Before inserting the lamp ensure that all contacts are clean. Contacts must be renewed at the slightest sign of corrosion. Sanding or filing down corroded areas is not recommended as this will only make the conducting surface between the pin and lampholder smaller, thus causing the lamp to overheat;
- The inert gas (Xenon) used in XBO lamps are under a pressure of several bar even when the bulb is cold. FOR SAFETY REASONS THE LAMP MAY ONLY BE INSERTED INTO THE LAMPHOUSE WITH THE PROTECTIVE JACKET FITTED;
- Do not twist or bend the fused quartz bulb when fitting the lamp as mechanical stresses MUST be avoided;
- Ensure that the spring contacts firmly surround the pins on the cap of the lamp. Do not apply unnecessary force when tightening the screws;
- After inserting the lamp, ensure that there is sufficient axial play in the lampholder. The lamp must be capable of unimpeded expansion when it warms up to operating temperature. Mechanical forces must not be applied to the fused quartz bulb;
- Electrical leads must be arranged in such a way that there is a sufficient air gap (approximately 40mm) between them and the lamphouse, in order to prevent flashovers from the ignition voltage. All flexible leads must have strain-relieving clamps;
- Before putting the lamp into service for the first time, check the polarity of the electrical connections. INCORRECT POLARITY WILL CAUSE IMMEDIATE DESTRUCTION OF THE LAMP;
- Before the protective jacket is removed, suitable protection must be worn i.e. face mask and gloves with wrist protection;
- Never touch the quartz bulb with bare hands, as fingerprints will make the glass cloudy and cause a severe loss of light. This may also cause recrystallisation and thus weaken the bulb material. Should the bulb be inadvertently touched, remove fingerprints with methylated spirit and a clean, soft paper towel. The bulb should then be wiped with distilled water. (NOTE: ALWAYS WEAR MASK AND GLOVES DURING CLEANING);
- All packaging and the protective jacket must be retained for re-use. Whenever removing a lamp, the protective jacket must always be used for safety reasons;

## Notes:

- 1) XBO lamps are designed for dc operation only. The dc current may only be varied within the limits of the current control range. A XBO lamp operates best at rated current; over the life of the lamp, the current may be increased to its maximum value to compensate for loss of light. The output of the lamp can be reduced by operating the lamp at minimum current but this does not prolong the life of the lamp;
- 2) For safety reasons, XBO lamps should be replaced once they reach the end of their average lamp life, and not later than 1.25 times their average lamp life. After this time there is an increased risk of the lamp exploding;
- 3) The anode (positive cap marked '+') must be on top when the lamp is inserted in the vertical position. If the anode is incorrectly inserted the arc will be unstable, the bulb will blacken more quickly and the lamp will prematurely fail;
- 4) The HT lead from the high voltage terminal of the Ignitor, must be connected to the cathode (negative cap marked '-'). If the lamp is connected with the wrong polarity it will be irreparably damaged after a very short time.
- 5) In all circumstances the lamp manufacturers data should be referred to when dealing with lamps.



## 7- Fault Finding

All fault finding must be conducted by a competent person or qualified Electrical Engineer.

Please refer to the following table for the trouble-shooting of Xenon lamps.

Fault	Cause	Remedy
<ul style="list-style-type: none"> <li>■ Wrong Polarity</li> </ul>	<ul style="list-style-type: none"> <li>■ Lamp incorrectly fitted</li> <li>■ Faulty wiring</li> </ul>	<ul style="list-style-type: none"> <li>■ Anode (large electrode) must always be on top in vertical burning position</li> <li>■ Check polarity, transpose connections if necessary</li> </ul>
<ul style="list-style-type: none"> <li>■ Cap overheated</li> <li>■ Cap temperature above 230°C</li> </ul>	<ul style="list-style-type: none"> <li>■ Faulty contacts</li> <li>■ Cooling equipment defective</li> </ul>	<ul style="list-style-type: none"> <li>■ Check terminals, tighten or renew</li> <li>■ Check cooling equipment and replace if necessary</li> </ul>
<ul style="list-style-type: none"> <li>■ Arc unsteady</li> </ul>	<ul style="list-style-type: none"> <li>■ Lamp operated outside current control range</li> <li>■ Magnetic stabilisation for horizontal operation defective</li> </ul>	<ul style="list-style-type: none"> <li>■ Correct current setting</li> <li>■ Check magnetic stabilisation</li> </ul>
<ul style="list-style-type: none"> <li>■ Bulb draws in air</li> </ul>	<ul style="list-style-type: none"> <li>■ Crack in graded seal caused by overheated cap</li> <li>■ Maximum cap temperature 230°C</li> </ul>	<ul style="list-style-type: none"> <li>■ Check terminals - tighten or renew</li> </ul>
<ul style="list-style-type: none"> <li>■ Glass erosion on fused quartz bulb</li> </ul>	<ul style="list-style-type: none"> <li>■ Lamp operated outside current control range</li> <li>■ Lamp service life exceeded</li> </ul>	<ul style="list-style-type: none"> <li>■ Correct current setting</li> <li>■ Check meter</li> </ul>
<ul style="list-style-type: none"> <li>■ Electrodes damaged</li> <li>■ Premature blackening</li> </ul>	<ul style="list-style-type: none"> <li>■ Current ripple too high</li> <li>■ Auxiliary mirror incorrectly adjusted</li> </ul>	<ul style="list-style-type: none"> <li>■ Have power supply inspected</li> <li>■ Adjust auxiliary mirror</li> </ul>
<ul style="list-style-type: none"> <li>■ Asymmetrical blackening of lamp (in horizontal burning position)</li> </ul>	<ul style="list-style-type: none"> <li>■ Lamp operated too long in same position</li> </ul>	<ul style="list-style-type: none"> <li>■ Turn lamp through 180° after half service life</li> </ul>

## Failure of Lamp to Ignite

In the event of the xenon lamp failing to light the following steps should be taken:

- 1) Check that the mains supply is connected to the input of the PSU. On operating the switch, if the lamp does not light, switch off mains supply and check all fuses;
- 2) On pressing remote starting switch the lamp still does not ignite, check the searchlight head. On your command get an operator to activate the starting switch for approximately 10 seconds. During this time listen for any noise (cracking or hissing) coming from within the barrel. If this arcing is heard switch off the supply at the mains. Remove the rear bezel to expose the two supply leads to the xenon lamp. Using a dry cloth wipe these leads to remove any dust, moisture or condensation that may have formed around the inside of the barrel. Replace the rear bezel, ensuring the latches are securely fastened, and perform the check again, listening for the cracking. If the lamp still fails to ignite, switch off at the mains and replace the xenon lamp in accordance with the safety procedures within this manual and the manufacturers information.

**Any further tests to be carried out with regards to lamp failure must be conducted by a competent electrical engineer and should not be carried out in an explosive atmosphere.**

- 3) Before a xenon lamp will ignite, the electrically insulated gas between the electrodes must be ionised. This is done by the ignitor which produces a high frequency voltage (up to 30,000 volts or higher). The ignitor is activated by switching the lamp on and a crackling or hissing noise should be heard. The ignitor is housed within the rear of the searchlight barrel. This is a totally encapsulated unit and repair is not advised. If found to be faulty a new ignitor must be fitted.

## Failure of Remote Focus Facility

The remote focus mechanism is controlled by a small electric motor situated at the rear of the searchlight barrel. If the focus of the light fails the following procedure should be adopted:

- 1) Remove the rear bezel from searchlight barrel and examine focus mechanism. If parts have become loose, tighten fasteners. The mechanism operates on a lever action and this should be checked for correct positioning;
- 2) If the mechanism is okay, check the supply to the motor. This can be done by simply placing a multi-meter across the motor terminals;
- 3) If supply is present, this indicates that the motor has failed. Replace the focus motor ensuring that the assembly is correct;
- 4) If no supply is present there is a fault in the motor gearbox. This should be examined and rectified accordingly.

**Note: If a fault occurs on the motor gearbox, the unit should be returned to Francis Searchlights Limited for fault evaluation and repair.**

## 8 - Maintenance and Servicing

In order to prolong the service life and performance of your searchlight, the following maintenance guidelines are recommended:

- Maintenance checks should be conducted before every voyage or at least every three months;
- Before checking, disconnect the equipment from the supply;
- Visually inspect the condition of the equipment;
- Any major or minor structural damage should be rectified immediately in order to reduce sympathetic wear;
- After inspection it may be necessary to clean the inside of the searchlight. The following procedure should be adhered to:
  - Remove the front bezel;
  - Clean the front glass inside and out using a proprietary glass cleaner or metal polish;
  - Clean the reflector if required;
  - Check the reflector mounting gaskets. If signs of corrosion or damage are evident, replace as necessary;
  - Ensure that the lampholder is free from corrosion or other damage;
  - Check earthing point for conductivity;
- It is advisable to check all seals and gaskets for signs of degradation. Renew if necessary;
- Upon completing all maintenance requirements the searchlight should be tested for full working order (approximately 20 minutes).

**If in any doubt as to the correct servicing procedures to adopt please contact your distributor/agent or the manufacturer who will be able to advise the best course of action for your product.**

## 9 - Wiring Diagram and General Assembly

Drawing Number	Description
C22462	Xenon RC Wiring Diagram
A2489	LX480RC Variable Speed 1Kw General Assembly drawing Control panel
C23591	Junction Box Assembly



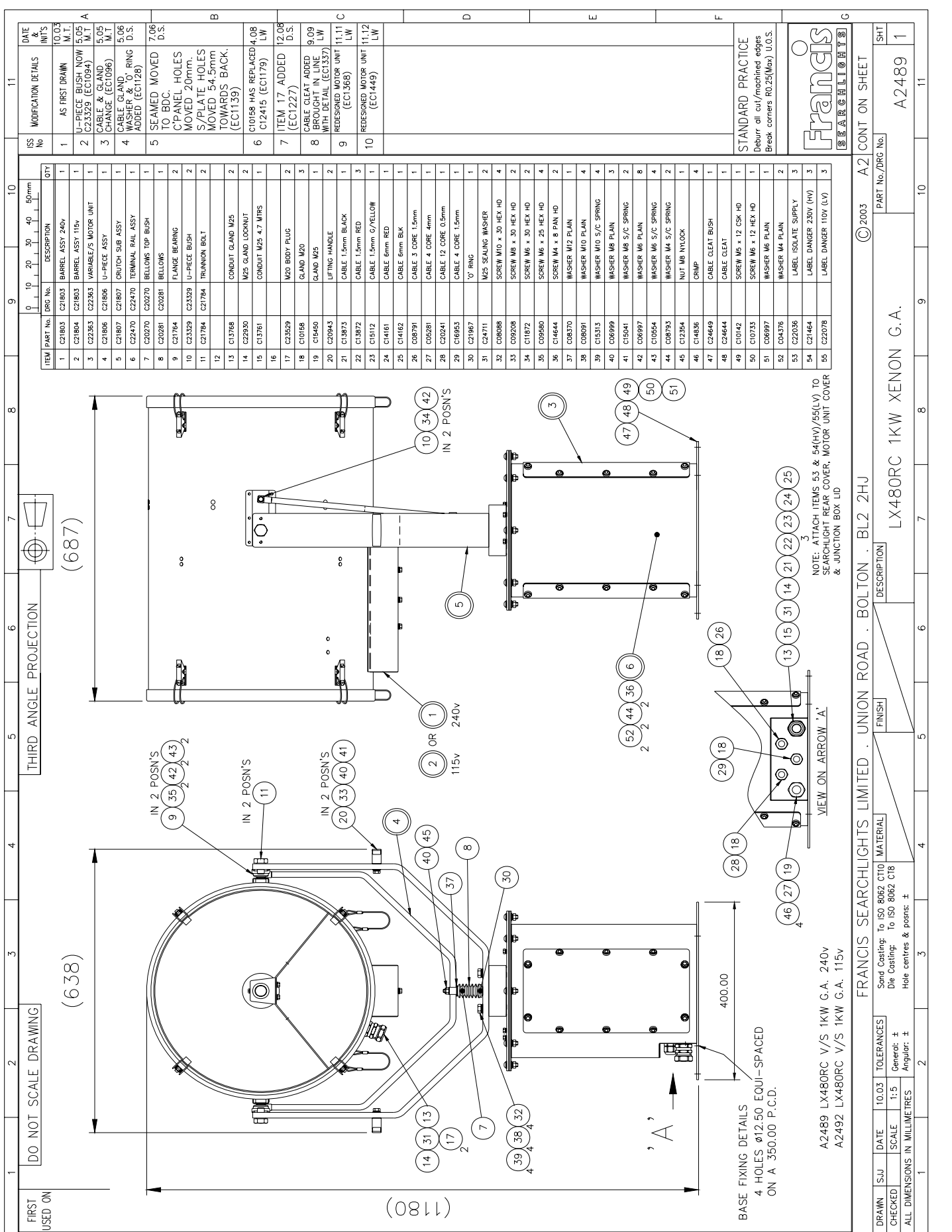

ITEM PART No.	DRG No.	DESCRIPTION	QTY	ISS No.	MODIFICATION DETAILS	DATE & INIT'S
1	C21805	BARREL ASSY 240v	1	1	AS FIRST DRAWN	10.03 M.T.
2	C21804	BARREL ASSY 115v	1	1	U-PIECE BUSH NOW	5.05 M.T.
3	C22363	VARIABLE/S MOTOR UNIT	1	2	C23329 (EC1094)	5.05 M.T.
4	C21806	U-PIECE ASSY	1	3	CABLE & GLAND CHANGE (EC1096)	5.05 M.T.
5	C21807	CRUTCH SUB ASSY	1	4	CABLE GLAND WASHER & O-RING ADDED (EC1128)	5.06 D.S.
6	C22470	TERMINAL RAIL ASSY	1	5	SEAMED MOVED TO BDC.	7.06 D.S.
7	C20270	BELLOWS TOP BUSH	1		C/PANEL HOLES MOVED 20mm.	
8	C20281	BELLOWS	1		S/P.LATE HOLES MOVED 54.5mm TOWARDS BACK. (EC1139)	
9	C21764	FLANGE BEARING	2			
10	C23329	U-PIECE BUSH	2			
11	C21784	TRUNNION BOLT	2			
12						
13	C13766	CONDUIT GLAND M25	2			
14	C22930	M25 GLAND LOCKNUT	2			
15	C13761	CONDUIT M25 4.7 METRS	1	6	C10168 HAS REPLACED C12415 (EC1179)	12.08 LW
16				7	ITEM 17 ADDED (EC1227)	12.08 D.S.
17	C23529	M20 BODY PLUG	2			
18	C10168	GLAND M20	3		CABLE GLEAT ADDED BROUGHT IN LINE WITH DETAIL (EC1337)	9.09 LW
19	C15450	GLAND M20	1		REDESIGNED MOTOR UNIT (EC1368)	11.11 LW
20	C20943	LIFTING HANDLE	2			
21	C13873	CABLE 1.5mm BLACK	1			
22	C13872	CABLE 1.5mm RED	3			
23	C15112	CABLE 1.5mm G/YELLOW	1		REDESIGNED MOTOR UNIT (EC1449)	11.12 LW
24	C14161	CABLE 6mm RED	1			
25	C14162	CABLE 6mm BLK	1			
26	C08791	CABLE 3 CORE 1.5mm	1			
27	C05281	CABLE 4 CORE 4mm	1			
28	C20241	CABLE 12 CORE 0.5mm	1			
29	C16953	CABLE 4 CORE 1.5mm	1			
30	C21967	'O' RING	1			
31	C24711	M25 SEALING WASHER	2			
32	C08688	SCREW M10 x 30 HEX HD	4			
33	C09208	SCREW M6 x 30 HEX HD	2			
34	C11872	SCREW M6 x 30 HEX HD	2			
35	C09580	SCREW M6 x 25 HEX HD	4			
36	C14644	SCREW M4 x 8 PAN HD	2			
37	C08370	WASHER M12 PLAIN	1			
38	C08691	WASHER M10 PLAIN	4			
39	C15313	WASHER M10 S/C SPRING	4			
40	C08699	WASHER M8 PLAIN	3			
41	C15041	WASHER M6 S/C SPRING	2			
42	C08697	WASHER M6 PLAIN	8			
43	C10054	WASHER M6 S/C SPRING	4			
44	C08793	WASHER M4 S/C SPRING	2			
45	C12354	NUT M8 NYLOCK	1			
46	C14836	CRIMP	4			
47	C24649	CABLE GLEAT BUSH	1			
48	C24644	CABLE GLEAT	1			
49	C10142	SCREW M5 x 12 CSK HD	1			
50	C10733	SCREW M6 x 12 HEX HD	1			
51	C08697	WASHER M6 PLAIN	1			
52	C04376	WASHER M4 PLAIN	2			
53	C22036	LABEL ISOLATE SUPPLY	3			
54	C21464	LABEL DANGER 230V (HV)	3			
55	C22078	LABEL DANGER 110V (LV)	3			

ITEM PART No.	DRG No.	DESCRIPTION	QTY	ISS No.	MODIFICATION DETAILS	DATE & INIT'S
1	C21805	BARREL ASSY 240v	1	1	AS FIRST DRAWN	10.03 M.T.
2	C21804	BARREL ASSY 115v	1	1	U-PIECE BUSH NOW	5.05 M.T.
3	C22363	VARIABLE/S MOTOR UNIT	1	2	C23329 (EC1094)	5.05 M.T.
4	C21806	U-PIECE ASSY	1	3	CABLE & GLAND CHANGE (EC1096)	5.05 M.T.
5	C21807	CRUTCH SUB ASSY	1	4	CABLE GLAND WASHER & O-RING ADDED (EC1128)	5.06 D.S.
6	C22470	TERMINAL RAIL ASSY	1	5	SEAMED MOVED TO BDC.	7.06 D.S.
7	C20270	BELLOWS TOP BUSH	1		C/PANEL HOLES MOVED 20mm.	
8	C20281	BELLOWS	1		S/P.LATE HOLES MOVED 54.5mm TOWARDS BACK. (EC1139)	
9	C21764	FLANGE BEARING	2			
10	C23329	U-PIECE BUSH	2			
11	C21784	TRUNNION BOLT	2			
12						
13	C13766	CONDUIT GLAND M25	2			
14	C22930	M25 GLAND LOCKNUT	2			
15	C13761	CONDUIT M25 4.7 METRS	1	6	C10168 HAS REPLACED C12415 (EC1179)	12.08 LW
16				7	ITEM 17 ADDED (EC1227)	12.08 D.S.
17	C23529	M20 BODY PLUG	2			
18	C10168	GLAND M20	3		CABLE GLEAT ADDED BROUGHT IN LINE WITH DETAIL (EC1337)	9.09 LW
19	C15450	GLAND M20	1		REDESIGNED MOTOR UNIT (EC1368)	11.11 LW
20	C20943	LIFTING HANDLE	2			
21	C13873	CABLE 1.5mm BLACK	1			
22	C13872	CABLE 1.5mm RED	3			
23	C15112	CABLE 1.5mm G/YELLOW	1		REDESIGNED MOTOR UNIT (EC1449)	11.12 LW
24	C14161	CABLE 6mm RED	1			
25	C14162	CABLE 6mm BLK	1			
26	C08791	CABLE 3 CORE 1.5mm	1			
27	C05281	CABLE 4 CORE 4mm	1			
28	C20241	CABLE 12 CORE 0.5mm	1			
29	C16953	CABLE 4 CORE 1.5mm	1			
30	C21967	'O' RING	1			
31	C24711	M25 SEALING WASHER	2			
32	C08688	SCREW M10 x 30 HEX HD	4			
33	C09208	SCREW M6 x 30 HEX HD	2			
34	C11872	SCREW M6 x 30 HEX HD	2			
35	C09580	SCREW M6 x 25 HEX HD	4			
36	C14644	SCREW M4 x 8 PAN HD	2			
37	C08370	WASHER M12 PLAIN	1			
38	C08691	WASHER M10 PLAIN	4			
39	C15313	WASHER M10 S/C SPRING	4			
40	C08699	WASHER M8 PLAIN	3			
41	C15041	WASHER M6 S/C SPRING	2			
42	C08697	WASHER M6 PLAIN	8			
43	C10054	WASHER M6 S/C SPRING	4			
44	C08793	WASHER M4 S/C SPRING	2			
45	C12354	NUT M8 NYLOCK	1			
46	C14836	CRIMP	4			
47	C24649	CABLE GLEAT BUSH	1			
48	C24644	CABLE GLEAT	1			
49	C10142	SCREW M5 x 12 CSK HD	1			
50	C10733	SCREW M6 x 12 HEX HD	1			
51	C08697	WASHER M6 PLAIN	1			
52	C04376	WASHER M4 PLAIN	2			
53	C22036	LABEL ISOLATE SUPPLY	3			
54	C21464	LABEL DANGER 230V (HV)	3			
55	C22078	LABEL DANGER 110V (LV)	3			

ITEM PART No.	DRG No.	DESCRIPTION	QTY	ISS No.	MODIFICATION DETAILS	DATE & INIT'S
1	C21805	BARREL ASSY 240v	1	1	AS FIRST DRAWN	10.03 M.T.
2	C21804	BARREL ASSY 115v	1	1	U-PIECE BUSH NOW	5.05 M.T.
3	C22363	VARIABLE/S MOTOR UNIT	1	2	C23329 (EC1094)	5.05 M.T.
4	C21806	U-PIECE ASSY	1	3	CABLE & GLAND CHANGE (EC1096)	5.05 M.T.
5	C21807	CRUTCH SUB ASSY	1	4	CABLE GLAND WASHER & O-RING ADDED (EC1128)	5.06 D.S.
6	C22470	TERMINAL RAIL ASSY	1	5	SEAMED MOVED TO BDC.	7.06 D.S.
7	C20270	BELLOWS TOP BUSH	1		C/PANEL HOLES MOVED 20mm.	
8	C20281	BELLOWS	1		S/P.LATE HOLES MOVED 54.5mm TOWARDS BACK. (EC1139)	
9	C21764	FLANGE BEARING	2			
10	C23329	U-PIECE BUSH	2			
11	C21784	TRUNNION BOLT	2			
12						
13	C13766	CONDUIT GLAND M25	2			
14	C22930	M25 GLAND LOCKNUT	2			
15	C13761	CONDUIT M25 4.7 METRS	1	6	C10168 HAS REPLACED C12415 (EC1179)	12.08 LW
16				7	ITEM 17 ADDED (EC1227)	12.08 D.S.
17	C23529	M20 BODY PLUG	2			
18	C10168	GLAND M20	3		CABLE GLEAT ADDED BROUGHT IN LINE WITH DETAIL (EC1337)	9.09 LW
19	C15450	GLAND M20	1		REDESIGNED MOTOR UNIT (EC1368)	11.11 LW
20	C20943	LIFTING HANDLE	2			
21	C13873	CABLE 1.5mm BLACK	1			
22	C13872	CABLE 1.5mm RED	3			
23	C15112	CABLE 1.5mm G/YELLOW	1		REDESIGNED MOTOR UNIT (EC1449)	11.12 LW
24	C14161	CABLE 6mm RED	1			
25	C14162	CABLE 6mm BLK	1			
26	C08791	CABLE 3 CORE 1.5mm	1			
27	C05281	CABLE 4 CORE 4mm	1			
28	C20241	CABLE 12 CORE 0.5mm	1			
29	C16953	CABLE 4 CORE 1.5mm	1			
30	C21967	'O' RING	1			
31	C24711	M25 SEALING WASHER	2			
32	C08688	SCREW M10 x 30 HEX HD	4			
33	C09208	SCREW M6 x 30 HEX HD	2			
34	C11872	SCREW M6 x 30 HEX HD	2			
35	C09580	SCREW M6 x 25 HEX HD	4			
36	C14644	SCREW M4 x 8 PAN HD	2			
37	C08370	WASHER M12 PLAIN	1			
38	C08691	WASHER M10 PLAIN	4			
39	C15313	WASHER M10 S/C SPRING	4			
40	C08699	WASHER M8 PLAIN	3			
41	C15041	WASHER M6 S/C SPRING	2			
42	C08697	WASHER M6 PLAIN	8			
43	C10054	WASHER M6 S/C SPRING	4			
44	C08793	WASHER M4 S/C SPRING	2			
45	C12354	NUT M8 NYLOCK	1			
46	C14836	CRIMP	4			
47	C24649	CABLE GLEAT BUSH	1			
48	C24644	CABLE GLEAT	1			
49	C10142	SCREW M5 x 12 CSK HD	1			
50	C10733	SCREW M6 x 12 HEX HD	1			
51	C08697	WASHER M6 PLAIN	1			
52	C04376	WASHER M4 PLAIN	2			
53	C22036	LABEL ISOLATE SUPPLY	3			
54	C21464	LABEL DANGER 230V (HV)	3			
55	C22078	LABEL DANGER 110V (LV)	3			

ITEM PART No.	DRG No.	DESCRIPTION	QTY	ISS No.	MODIFICATION DETAILS	DATE & INIT'S
1	C21805	BARREL ASSY 240v	1	1	AS FIRST DRAWN	10.03 M.T.
2	C21804	BARREL ASSY 115v	1	1	U-PIECE BUSH NOW	5.05 M.T.
3	C22363	VARIABLE/S MOTOR UNIT	1	2	C23329 (EC1094)	5.05 M.T.
4	C21806	U-PIECE ASSY	1	3	CABLE & GLAND CHANGE (EC1096)	5.05 M.T.
5	C21807	CRUTCH SUB ASSY	1	4	CABLE GLAND WASHER & O-RING ADDED (EC1128)	5.06 D.S.
6	C22470	TERMINAL RAIL ASSY	1	5	SEAMED MOVED TO BDC.	7.06 D.S.
7	C20270	BELLOWS TOP BUSH	1		C/PANEL HOLES MOVED 20mm.	
8	C20281	BELLOWS	1		S/P.LATE HOLES MOVED 54.5mm TOWARDS BACK. (EC1139)	
9	C21764	FLANGE BEARING	2			
10	C23329	U-PIECE BUSH	2			
11	C21784	TRUNNION BOLT	2			
12						
13	C13766	CONDUIT GLAND M25	2			
14	C22930	M25 GLAND LOCKNUT	2			
15	C13761	CONDUIT M25 4.7 METRS	1	6	C10168 HAS REPLACED C12415 (EC1179)	12.08 LW
16				7	ITEM 17 ADDED (EC1227)	12.08 D.S.
17	C23529	M20 BODY PLUG	2			
18	C10168	GLAND M20	3		CABLE GLEAT ADDED BROUGHT IN LINE WITH DETAIL (EC1337)	9.09 LW
19	C15450	GLAND M20	1		REDESIGNED MOTOR UNIT (EC1368)	11.11 LW
20	C20943	LIFTING HANDLE	2			
21	C13873	CABLE 1.5mm BLACK	1			
22	C13872	CABLE 1.5mm RED	3			
23	C15112	CABLE 1.5mm G/YELLOW	1		REDESIGNED MOTOR UNIT (EC1449)	11.12 LW
24	C14161	CABLE 6mm RED	1			
25	C14162	CABLE 6mm BLK	1			
26	C08791	CABLE 3 CORE 1.5mm	1			
27	C05281	CABLE 4 CORE 4mm	1			
28	C20241	CABLE 12 CORE 0.5mm	1			
29	C16953	CABLE 4 CORE 1.5mm	1			
30	C21967	'O' RING	1			
31	C24711	M25 SEALING WASHER	2			
32	C08688	SCREW M10 x 30 HEX HD	4			
33	C09208	SCREW M6 x 30 HEX HD	2			
34	C11872	SCREW M6 x 30 HEX HD	2			
35	C09580	SCREW M6 x 25 HEX HD	4			
36	C14644	SCREW M4 x 8 PAN HD	2			
37	C08370	WASHER M12 PLAIN	1			
38	C08691	WASHER M10 PLAIN	4			
39	C15313	WASHER M10 S/C SPRING	4			
40	C08699	WASHER M8 PLAIN	3			
41	C15041	WASHER M6 S/C SPRING	2			
42	C08697	WASHER M6 PLAIN	8			</

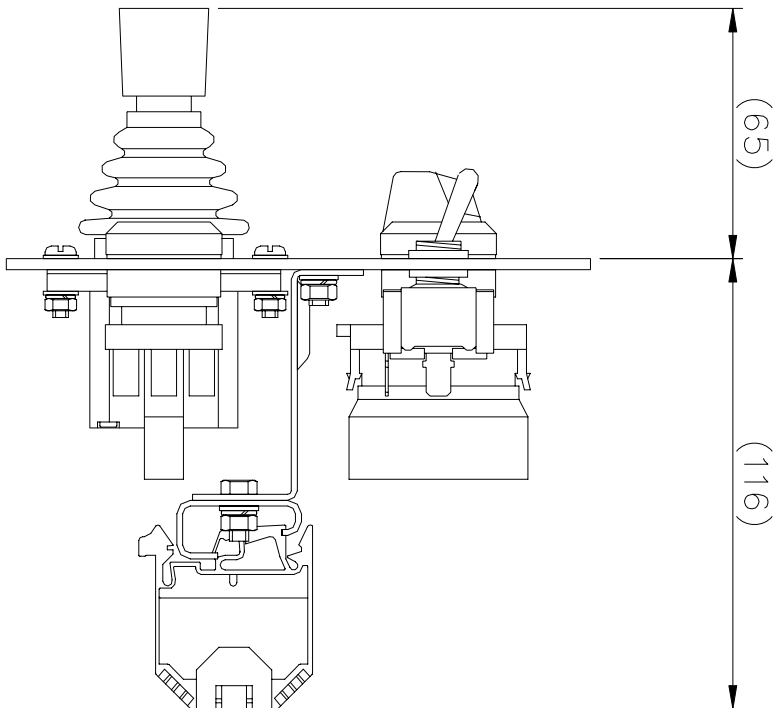
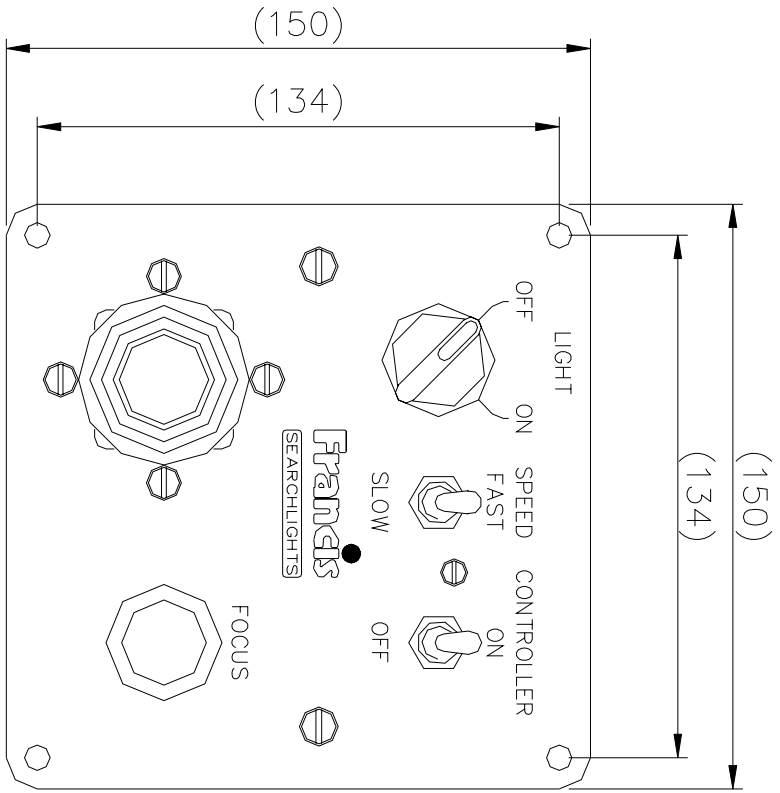

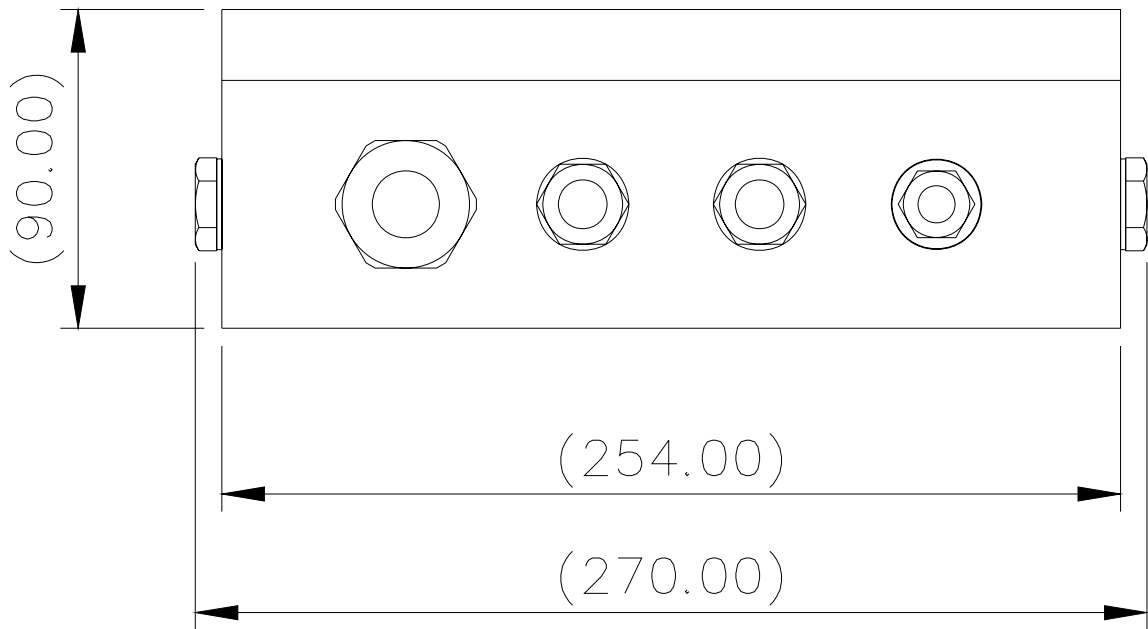
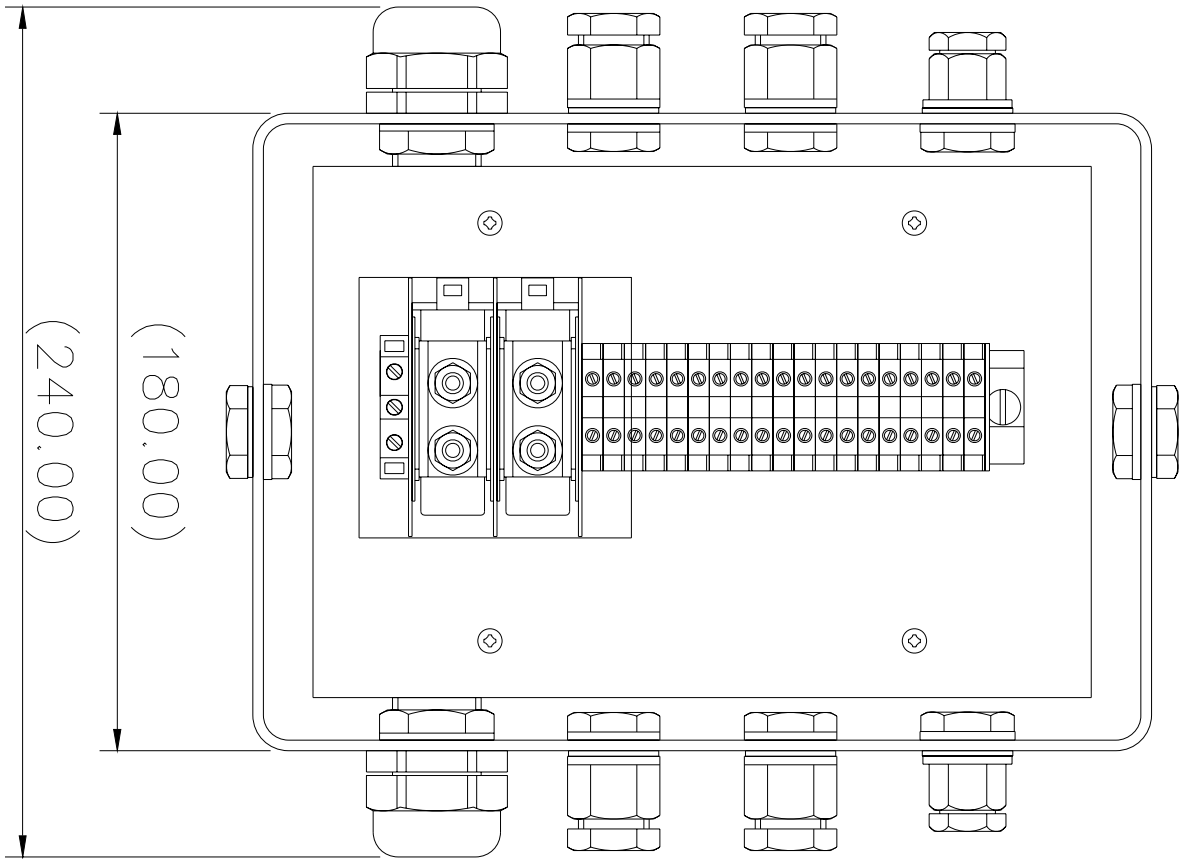

[Back To Top](#)



## 10 - Spare Parts List

The following spare parts can be ordered directly from the manufacturer:

<b>Part Number</b>	<b>Description</b>
C13503-00	Power supply unit (240v)
C15326-00	Power supply unit (115v)
C12081-00	Ignitor (240v)
C12080-00	Ignitor (115v)
C16930-00	Fan 240v
C16931-00	Fan 115v
D21229	1Kw Xenon Lamp
C14143-00	Switch 10A - On/Off
C14142-00	Switch – Focus
C22347-00	Joystick
C22941-00	Switch (Controller/Speed)
C20707-00	Front glass
C20568-00	Front glass/ Rear bezel gasket
C15458-00	Motor - Remote Focus
C15459-00	Bearing
C23277-01	Heater & Fuse Assembly
C21714-00	Reflector
C20281-00	Bellows
C20070-00	Drainage plug
C22268-01	Breather Assembly

### Motor Gearbox Spares

C22403-01	Pan Motor S/Assy
C22287-00	Tilt Motor
C22380-00	Microswitch no lever
C22382-00	Microswitch with lever
C24030-01	'I' Drive Pan Speed Controller
C24060-01	'I' Drive Tilt Speed Controller
C23530-01	P.S.U
C22381-00	Pedestal Top Sealing Gasket
C26185-00	Pedestal Cover Gasket

In order to prolong the life and performance of your product, we recommend that you only specify Francis Searchlights spare parts. This will ensure that any warranties on your equipment will not be invalidated.

When ordering spare parts please contact the Sales Department at Francis Searchlights Limited. Please quote searchlight model and serial number at all times. This will enable a fast response to your spares' requirements.

[Back To Top](#)