



## User Instruction & Installation Manual

### FR230 Manually Operated Tungsten Halogen Searchlight



#### Product Reference Number:

A2808 – FR230 Deck LV  
A2810 – FR230 Cabin LV  
A2807 – FR230 Deck Pedestal LV  
A2809 – FR230 Cabin Pedestal LV

A2897 – FR230 Deck HV  
A2902 – FR230 Cabin HV  
A2904 – FR230 Deck Pedestal HV  
A2903 – FR230 Cabin Pedestal HV

#### *Manufacturer's details:*

Francis Searchlights Ltd  
Union Road, Bolton  
Lancashire, BL2 2HJ, UK  
Tel: +44 (0) 1204 558960  
Fax: +44 (0) 1204 558979  
<http://www.francis.co.uk>  
E-mail: [sales@francis.co.uk](mailto:sales@francis.co.uk)

#### *Distributor details:*

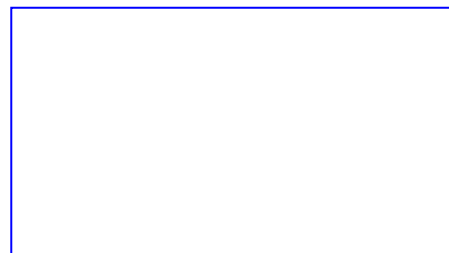

**Manual Part Number: C17128**  
**13.10.16 Issue: 14**

# CONTENTS

	Page
Introduction.....	1
Safety Precautions.....	2
Technical Data.....	3
Unpacking Instructions.....	3
Installation Instructions.....	4
Safety Precautions.....	4
Preparing the Mounting Position.....	4
Mounting the Searchlight.....	4
Power Supply Requirements.....	4
Method of Electrical Connection.....	5
Operating Instructions.....	7
Setting to Work.....	7
Testing.....	8
Fault Finding.....	9
Fault.....	9
Remedy.....	9
Maintenance & Service Requirements.....	10
<b>Spare Parts</b>	
Barrel Assembly.....	11
Lampholder GX6.35.....	12
Deck Mount.....	13
Deck Pedestal Mount.....	14
Cabin Trainer Mount.....	15
Cabin Pedestal Trainer Mount.....	16
Seal Kits.....	17
Spare Parts Ordering.....	17
Parts Disposal.....	17
Sales & Service.....	17
Guarantee.....	18

## Introduction

**It is imperative that this manual is read carefully before installing or using your equipment. For your future reference this manual should be kept in a safe place.**

Thank you for specifying a product from the Francis Searchlights Ltd range. All Francis products are designed to give complete customer satisfaction and are manufactured to the highest engineering standards in order to ensure optimum performance and service life.

The Francis FR series searchlights combine design features proven over many years of service in the most hazardous conditions in both marine and land installations.

In order to prolong the life and performance of your product, we recommend that you only specify Francis Searchlight spare parts. This will also ensure that any warranties on your equipment will not be invalidated. Information on spares ordering and parts is provided in this manual.

Should you ever need to contact Francis Searchlights Ltd regarding your equipment, please quote the product serial number at all times.

## Safety Precautions

The following instructions must be adhered to in order to ensure a safe working environment and the safety of the user.

**Note: When manoeuvring the searchlight into its fixing position, suitable lifting points must be chosen in order to prevent damage to the equipment or personal injury.**

Prevent rain, snow, condensation and water droplets from contacting the lamp as this may cause bulb failure, and possible shattering.

Quartz halogen lamps run with a high internal pressure in excess of atmospheric. Whilst the construction is inherently strong, there is a slight risk of the lamp shattering.

Never look directly into an illuminated searchlight as this may cause severe damage to eyesight. If it is necessary to inspect a lamp whilst in operation, always wear suitable protective goggles.

Should it be necessary to examine the lamp with the front bezel removed always use a protective shield to ensure a safe working environment.

Never attempt to clean the lamp when in use.

Searchlights get hot. Never touch the unit when lit and always allow at least ten minutes for cooling down after turning off.

Ensure the lamp has cooled sufficiently before removal. During the cooling down period avoid mechanical or thermal shock to the lamp as this may cause shattering.

If undue force appears necessary to remove the lamp, the equipment should be inspected by a competent person, or contact the manufacturer.

When breaking a lamp for disposal, care must be taken to ensure that the fragments are safely contained. Precautions must be taken against flying glass and other fragments. This operation should be performed outdoors or in a well-ventilated area. In ALL cases reference should be made to the lamp manufacturer's instructions packed with the lamp.

Due to the vast range of lamps available, it may appear possible that more powerful lamps can be used in the equipment for which it was designed. Even when the unit will physically accept a higher wattage lamp, this substitution is not recommended as it could be dangerous.

## Technical Data

This product has been designed to operate in accordance with the product specification. The FR230 searchlight has the following features.

- All marine grade materials and fixings;
- Parabolic glass reflector;
- Powder coated & stove enamel paint finish;
- External lamp focus adjustment;
- Enclosure protection to IP56;
- 450° horizontal rotation;
- +35 to -30° vertical movement;
- Toughened front glass;
- Weights           9.8 Kg (Deck)  
                      12.1 Kg (Cabin)  
                      14.9 Kg (Deck Pedestal)  
                      17.1 Kg (Cabin Pedestal)

Lamp Part Number	Lamp Cap	Voltage (V)	Wattage (W)	Range (M)	PBCP (x 1000)	Divergence (°)
D9848	GX6.35	12	100	643	414	2
D14795	GX6.35	24	150	784	614	2
D4695	GX6.35	24	250	910	828	2
D9851	GX6.35	24	250	1095	1200	2
D16883	GX6.35	120	300	912	832	4.9
D16841	GX6.35	230	300	888	790	4.9

## Unpacking Instructions

Care should be taken when unpacking the searchlight, so as not to cause damage to the equipment or cause personal injury. A visual inspection of the equipment should be conducted to check for damage during transit or damaged lamps.

Enclosed in the packing is the base sealing gasket. This should be retained for installation purposes.

## Installation instructions

The following instructions should be read and fully understood prior to installing the equipment to ensure correct procedures are followed and all safety precautions are observed.

Note: If the equipment has been in storage for a considerable time, it is advisable to conduct a routine maintenance check on all parts before installation.

### Safety Precautions

This equipment should not be connected to an electrical supply before being installed. Installation procedures should be adhered to in order to ensure a safe working environment and reduce the risk of damage or injury.

### Preparing the mounting position

Using the template provided mark out and drill the fixing holes through the deck or cabin roof. In the case of cabin control models, a centre hole is also required to allow the mechanism to pass through.

### Mounting the searchlight

Fit the 'O' ring in position and bolt the searchlight base securely down. On an uneven surface it is necessary to use a suitable sealant, such as silicone, in order to ensure a weather proofed joint.

For cabin control models it is necessary to remove the underdeck control assembly prior to installation.

Using the Allen key provided, the five grub screws on the underdeck mechanism should be loosened to allow the underdeck control assembly to be removed. The outer tube can then be positioned through the centre hole. The searchlight base can then be securely fixed as stated above. Upon installation, re-assemble the underdeck control mechanism, ensuring that the grub screws are secure, and the mechanism operates correctly.

### Power supply requirements

For safety purposes, only competent personnel should perform the electrical installation. All equipment should be installed to current electrical regulations and standards.

In order to obtain maximum light output from the searchlight, it is essential that the full operating voltage of the lamp fitted is applied to the lampholder contacts.

## Method of electrical connection

Disconnect the supply before working on the electrical system.

The searchlight must be connected to a fused electrical supply, using suitably sized cable. If the searchlight is positioned a considerable distance from the supply, provision must be made in the cable size in order to overcome the voltage drop. The following table should be used for indication only.

### 12 volt 100w

Cable size	Maximum length of cable
1.5mm <sup>2</sup>	2 Metres
2.5mm <sup>2</sup>	3 Metres
4mm <sup>2</sup>	5 Metres
6mm <sup>2</sup>	7 Metres
10mm <sup>2</sup>	12 Metres

### 24 volt 150w

Cable size	Maximum length of cable
1.5mm <sup>2</sup>	5 Metres
2.5mm <sup>2</sup>	8 Metres
4mm <sup>2</sup>	13 Metres
6mm <sup>2</sup>	20 Metres
10mm <sup>2</sup>	34 Metres

### 24 volt 250w

Cable size	Maximum length of cable
1.5mm <sup>2</sup>	3 Metres
2.5mm <sup>2</sup>	5 Metres
4mm <sup>2</sup>	8 Metres
6mm <sup>2</sup>	12 Metres
10mm <sup>2</sup>	20 Metres

### 120 volt 300w

Cable size	Maximum length of cable
1.5mm <sup>2</sup>	13 Metres
2.5mm <sup>2</sup>	21 Metres
4mm <sup>2</sup>	32 Metres
6mm <sup>2</sup>	50 Metres
10mm <sup>2</sup>	84 Metres

### 230 volt 300w

Cable size	Maximum length of cable
1.5mm <sup>2</sup>	24 Metres
2.5mm <sup>2</sup>	39 Metres
4mm <sup>2</sup>	62 Metres
6mm <sup>2</sup>	96 Metres
10mm <sup>2</sup>	161 Metres

Whenever possible cable terminations should be made below deck and with approved terminal devices.

If a spare auxiliary fuse or circuit breaker is not available, one of the correct type and rating should be fitted and connected to a positive supply. It is advisable to locate a bus bar or main connection and avoid any direct connection to the supply.

When wiring the negative supply, the direct connection to a battery or supply, or metal hull/object, should be avoided. It is advisable to use a suitable terminal block or connection.

For ease of use a single pole switch, of the appropriate rating, should be fitted in a convenient location. All cable lengths should be kept to a minimum.



# Operating Instructions

This equipment is designed for use out of doors, in free air.

Never place anything on, or cover, the searchlight when in operation as this may present a hazard.

The searchlight can be positioned using the elevation and pan lock wheels. When in the desired position the lock wheels must be securely fastened to prevent damage.

The beam of the searchlight can be adjusted to give a variety of 'spreads'. Using the focus wheel underneath the searchlight barrel the beam can be moved from 'spot' to 'flood' positions.

The breather unit at the rear of the searchlight ensures a steady airflow to prevent any vacuum forming with the barrel.

**Note: This product should not be used for any purposes other than for which it was designed. Any modifications to the product should not be undertaken before consulting the manufacturer or agent.**

## Setting to Work

**Safe service in use necessitates the strict observance of the following precautions.**

Any article fabricated from quartz or glass is inherently fragile and care should therefore be taken at all times when handling lamps.

Eye protection must be worn when handling lamps that have been removed from their packaging materials. The protective sleeve should not be removed from the lamp for safety reasons as there is a remote possibility of the lamp shattering violently, especially if it is submitted to mechanical shock or vibration.

Quartz lamps should not become contaminated with oils, grease or come into contact with skin.

When fitting the lamp:

- Always isolate the equipment from the supply before inserting a lamp;
- Ensure the circuit is suitably fused;
- Ensure that the lamp is of the recommended type and rating;
- Check the lampholder is in good condition. If the contacts show any sign of corrosion the lampholder should be replaced;
- Check that the lampholder is in a good dry condition. Never allow water to collect in the Lamp fitting or come into contact with the lamp;

To fit the lamp:

- Unclip the latches on the front of the searchlight, allowing the bezel and glass to hang clear on the captive latch.
- For easier access the light shield may be removed by firstly undoing the centre screw;
- Cut open one end of the protective sleeve surrounding the lamp;
- Using the sleeve to prevent the fingers coming into contact with the lamp, position the two lamp pins above the holes in the lampholder;
- Gently push the lamp into the lampholder and discard the protective sleeve;
- Replace the light shield, fixing the centre screw in position;
- Position the front bezel onto the searchlight and retain in position using the latches;

## Testing

Upon correct installation and connection to an electrical supply, the equipment can be tested in order to ensure its correct performance. This work must be carried out by a competent person with some knowledge of electrical equipment.

Equipment required:

Multi meter with leads;  
Ammeter;

Using the equation  $P = VI$  the approximate power output of the equipment can be calculated in the following way:

- Using the multi meter take a voltage reading;
- Using the ammeter, take an amp reading from the live cable to the lamp;
- Multiply these values together to give an approximate wattage;

For example:

Using a 24v 150w Tungsten Halogen Lamp.

Voltage reading = 24 volts.

Amps reading = 6 amps.

Therefore:

Wattage =  $24 \times 6 = 144$  watts.

# Fault Finding

If a fault occurs the following procedures should be adopted. Any work to be carried out should be conducted by a competent person. A multi meter should be used for fault finding purposes.

## Fault

Lamp fails to light

Causes

- Power not supplied;
- Fuse blown;
- Failed lamp;

## Remedy

- Check voltage at supply / battery. If necessary, recharge battery. If supply is not present fault is at customers supply; if power is present, see next remedy;
- Check fuse for visual failure. If none noticeable check fuse for continuity. If fuse found to be faulty, replace with new part. If found to be working correctly see next remedy.
- Firstly, check supply at lampholder connecting block (within searchlight barrel) if supply is present, disconnect unit from power supply before removing the lamp. If noticeable damage to filament is present, the lamp will have failed. The lamp can also be checked using a multi meter for continuity of the filament. Replace new lamp following all precautions mentioned previously and lamp manufacturer's instruction.

## Maintenance and Service Requirements

In order to prolong the service life and performance of your searchlight, the following maintenance guidelines are recommended.

- Maintenance checks should be conducted before every voyage or every three months;
- Before checking, disconnect the equipment from the supply;
- Visually check the condition of the equipment;
- Any major or minor structural damage or defect should be rectified immediately;
- After inspection it may be necessary to clean the inside of the searchlight. The following procedure should be adhered to;
  - Remove the front bezel;
  - Clean the front glass inside and out using a proprietary glass cleaner;
  - Clean the reflector, if required;
  - Check the rubber reflector mounting pads. If signs of corrosion or damage are evident, replace as necessary;
  - Ensure the lampholder is free from corrosion or damage;
  - Check the earth point for conductivity;
  - Check lampholder assembly for signs of damage or wear. If required apply a little grease to the focus assembly, upon completion of these checks, the searchlight should be tested for full working order (approximately 15 minutes);
  - Every six months the external movement mechanisms i.e. lock wheels, elevation and pan mechanisms, may be lightly lubricated.

**Note: It is advisable to check all seals and gaskets for degradation. If replacement is necessary, the kit numbers are quoted in the back of the spares lists.**

## Barrel Assembly

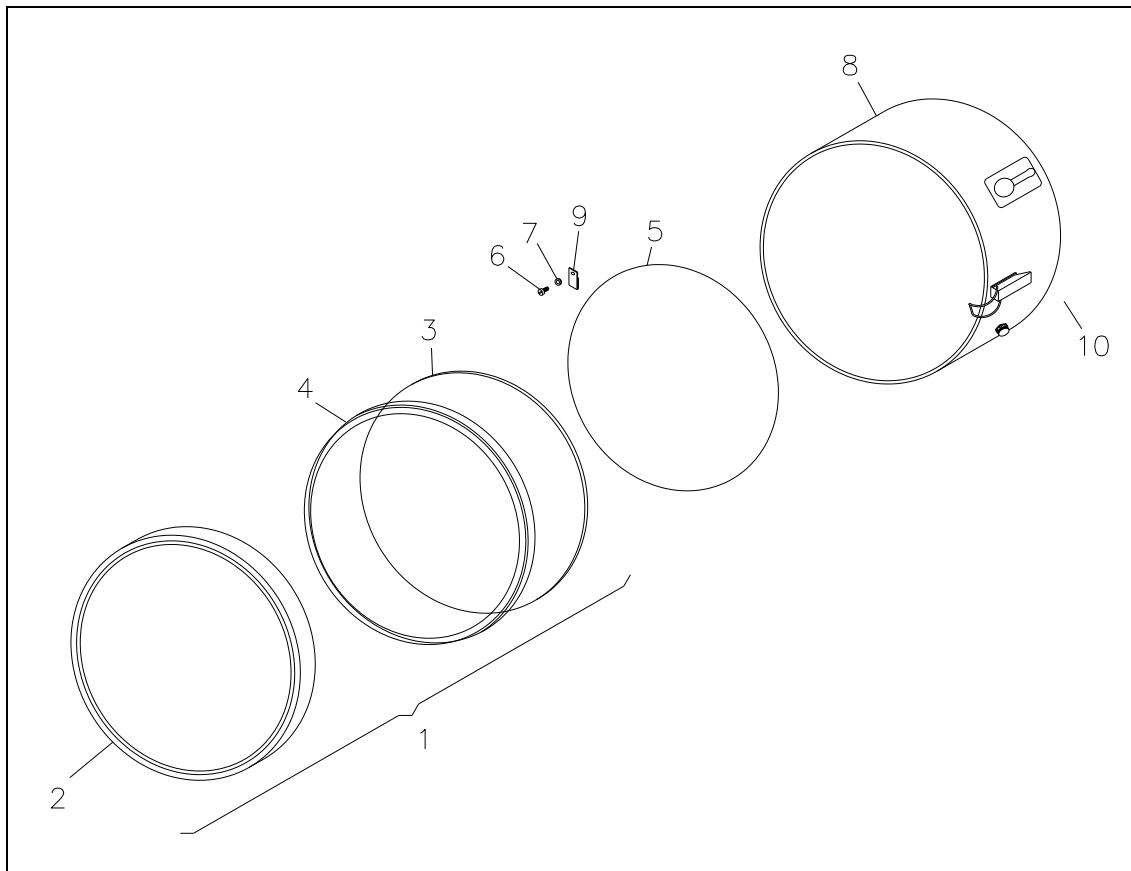

Item No.	Description	Part No.	No. Off
1	Front Bezel Assembly	C27279-01	1
2	Front Bezel	C21119-38	1
3	Front Glass	C27275-00	1
4	Front Glass Gasket	C21141-00	1
5	Reflector	C06675-00	1
6	Screw M5 x 8 Pan Head	C10140-00	3
7	Washer M5 S/C Spring	C09231-00	3
8	Barrel Sub Assembly	C16886-01	1
9	Mirror Clip Sub Assembly	C10055-01	3
10	Breather Unit Assembly	C22268-01	1

## Lampholder Assembly LV & HV

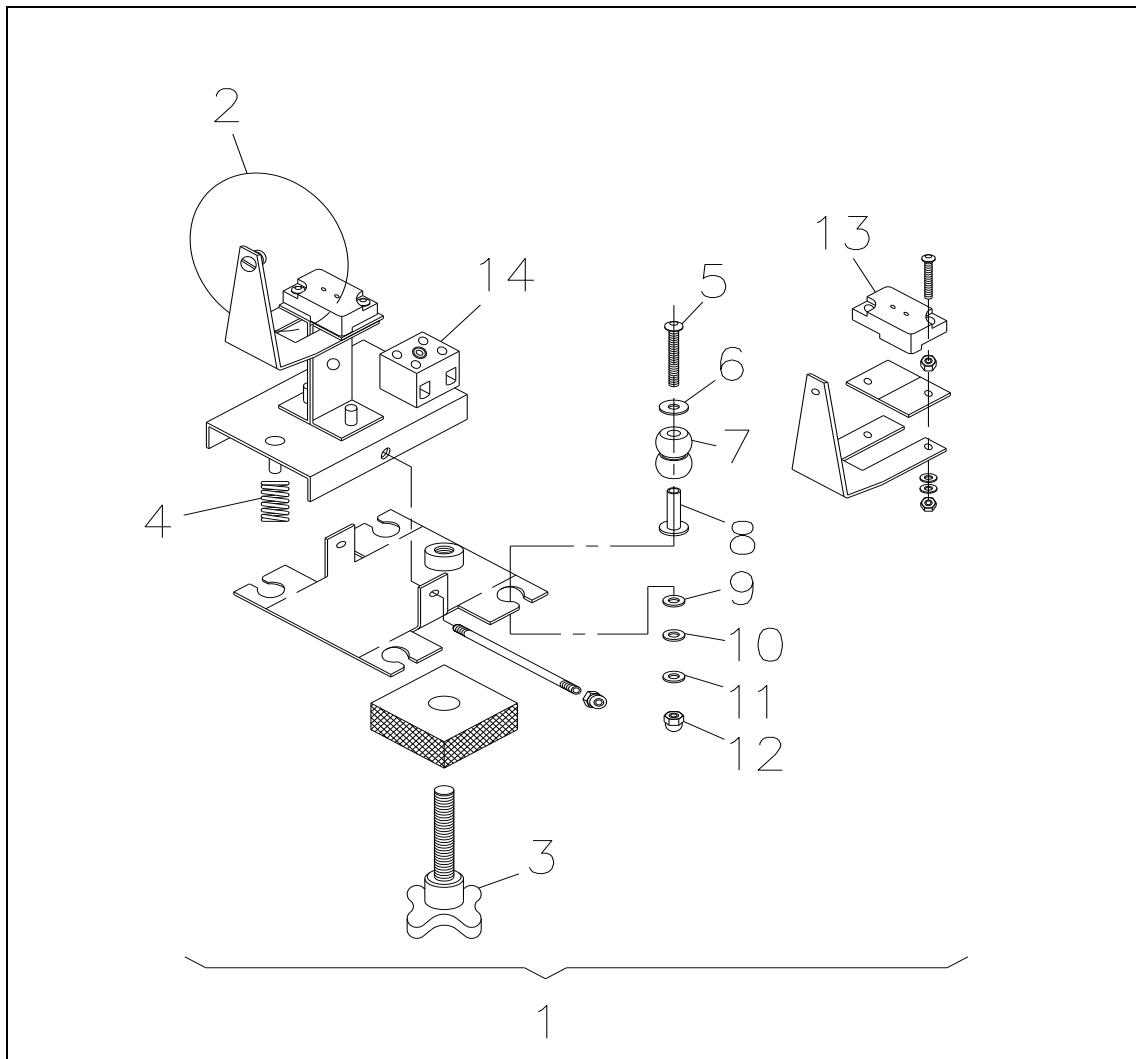

Item No.	Description	Part No.	No. Off
1	FR230 LV Lampholder Conversion Kit	C13033-01	1
1	FR230 HV Lampholder Conversion Kit	C16888-01	1
2	FR230 LV Lampholder Assembly	C16982-01	1
2	FR230 HV Lampholder Assembly	C16891-01	1
3	Focus Wheel Assembly	C09888-01	1
4	Spring	C08827-00	1
5	Screw M4 x 30 Button Head	C16764-00	4
6	Washer M4 x 12 O/D	C20637-00	4
7	AV Mount	C16761-00	4
8	AV Bush	C16762-01	4
9	Washer M4 Nylon	C15272-00	4
10	Washer M4 Plain	C04376-00	4
11	Washer M4 S/C	C08793-00	4
12	Dome Nut M4	C11183-00	4
13	LV GX6.35 Lampholder	C16878-00	1
14	Terminal Block	C02027-00	1

## Deck Mount – C15070-01

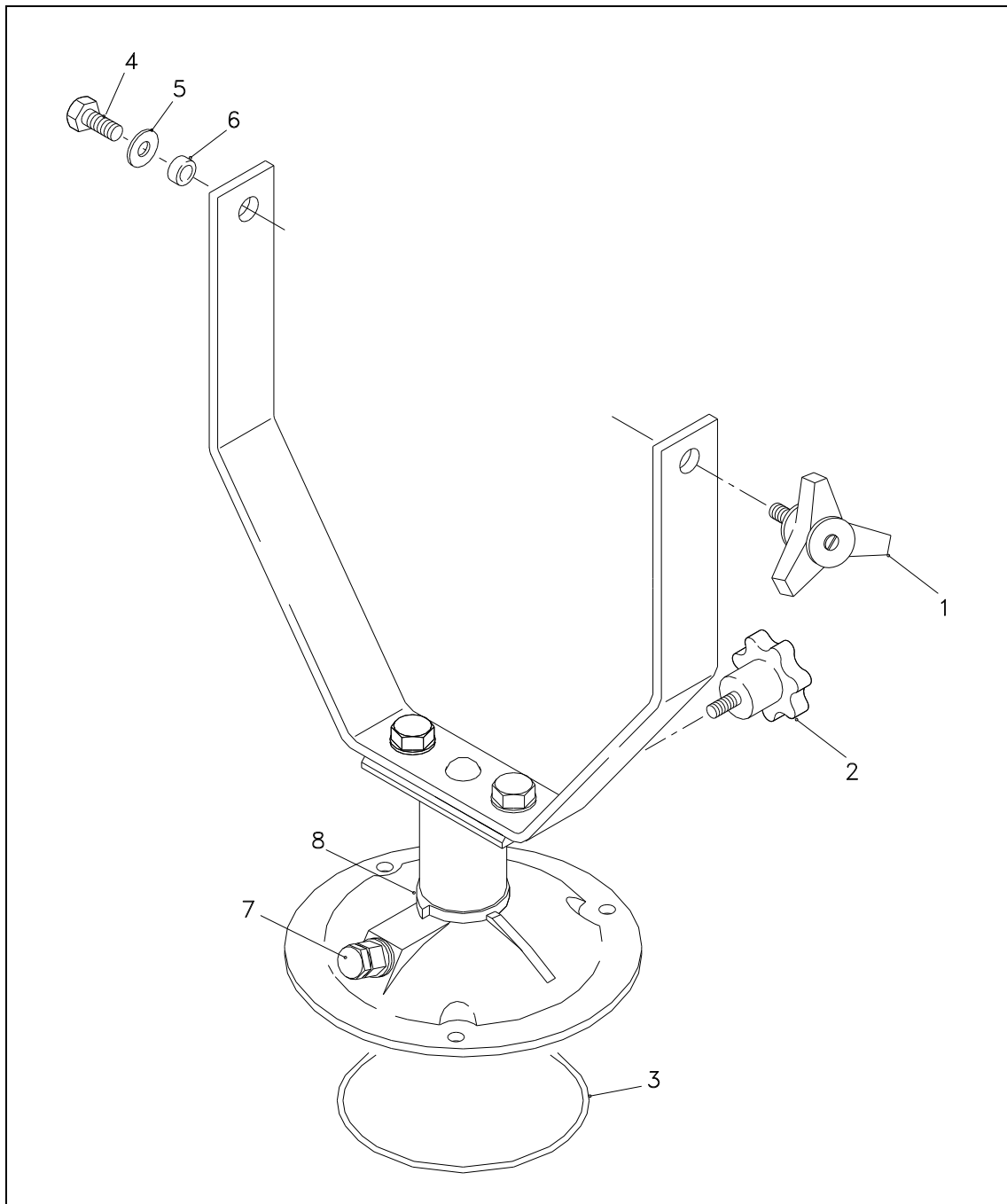

Item No.	Description	Part No.	No. Off
1	Elevation Lock Wheel Assembly	C15395-01	1
2	Lock wheel Assembly	C11025-01	1
3	'O' Ring Seal	C10168-00	1
4	Screw M10 x 20 Button Head	C08094-00	1
5	Washer M10 Plain	C08091-00	1
6	Trunnion Spacer	C10254-01	1
7	Cable Gland	C10158-00	1
8	Floating Stop	C08929-38	1

# Deck Pedestal Mount C15154-01

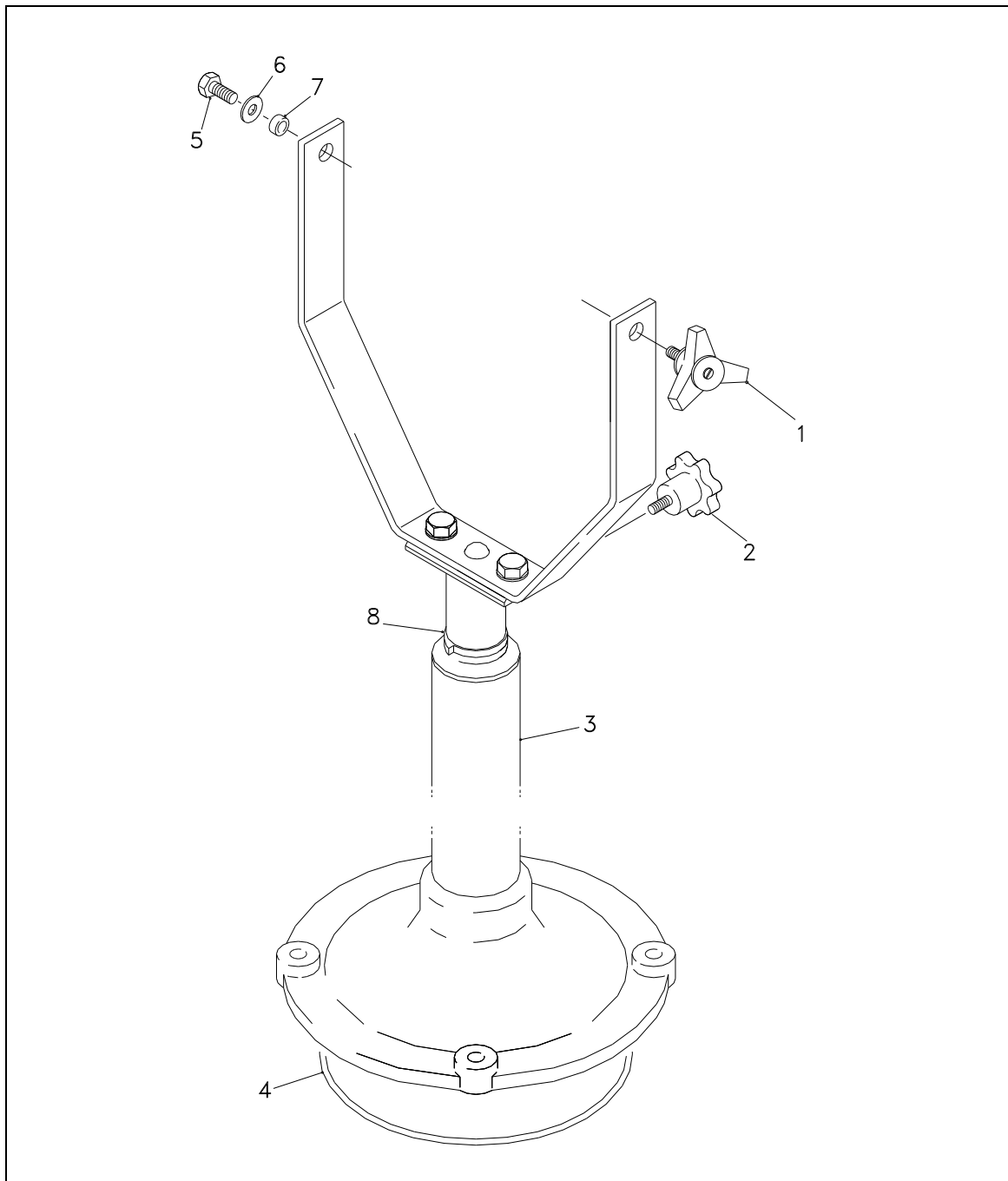

Item No.	Description	Part No.	No. Off
1	Elevation Lock Wheel Assembly	C15395-01	1
2	Lock wheel Assembly	C11025-01	1
3	Pedestal Assembly	C10073-38	1
4	'O' Ring Seal	C10170-00	1
5	Screw M10 x 20 Button Head	C08094-00	1
6	Washer M10 Plain	C08091-00	1
7	Trunnion Spacer	C10254-01	1
8	Floating Stop	C08929-38	1



# Cabin Trainer Mount – C15164-01

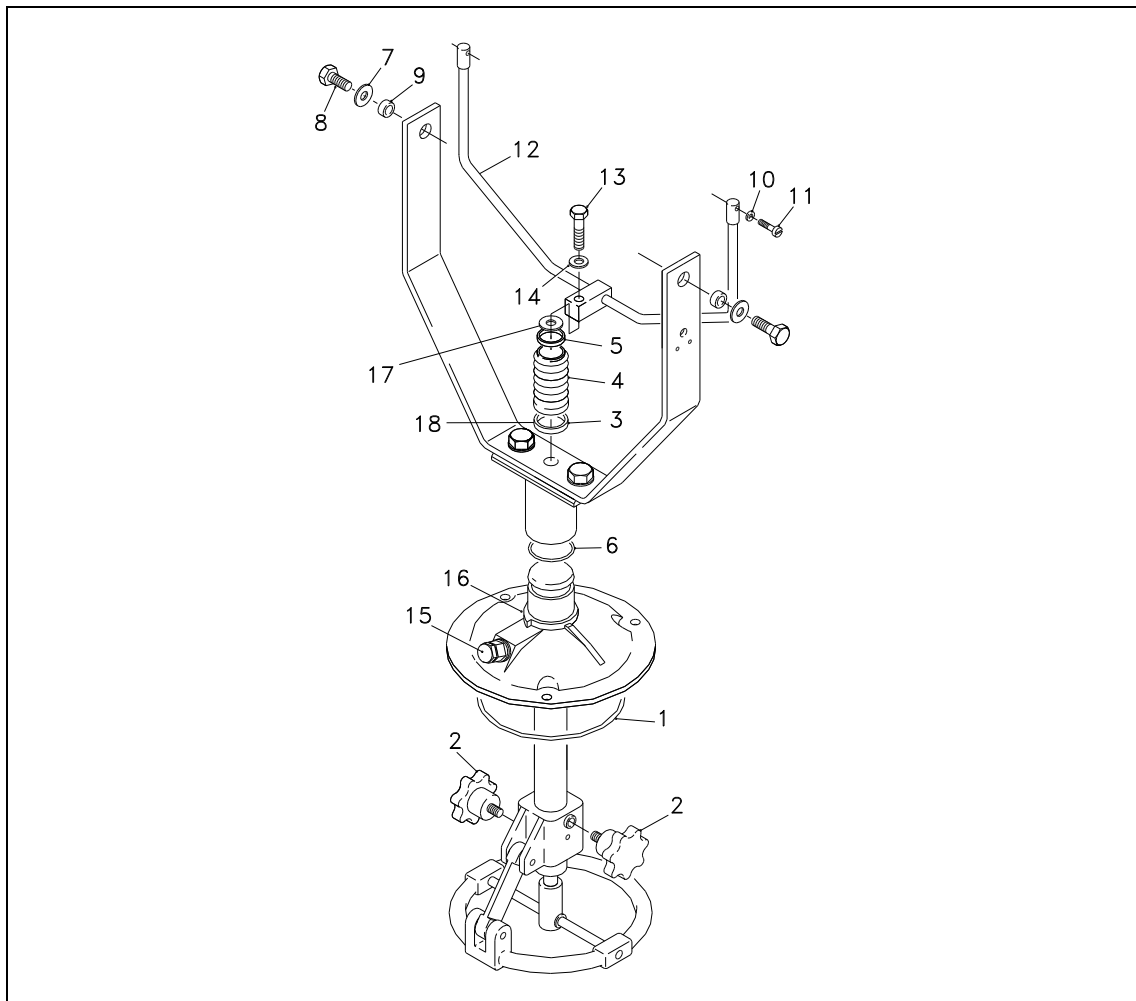

Item No.	Description	Part No.	No. Off
1	'O' Ring Seal Base	C10168-00	1
2	Lock Wheel Assembly	C11026-01	2
3	Bellows Bottom Bush	C20269-01	1
4	Bellows	C20281-00	1
5	Bellows Top Bush	C20270-01	1
6	'O' Ring Seal Spigot	C10169-00	1
7	Washer M10 Plain	C08091-00	2
8	Screw M10 x 20 Button Head	C08094-00	2
9	Trunnion Spacer	C10254-01	2
10	U-Piece Bush	C08932-01	2
11	Screw M6 x 20 Button Head	C10174-00	2
12	U-Piece Assembly	C10086-38	1
13	Screw M8 x 35 Hex Head	C08796-00	1
14	Washer M8 Plain	C06999-00	1
15	Cable Gland	C10158-00	1
16	Floating Stop	C08929-38	1
17	Washer M12 Plain	C08370-00	1
18	'O' Ring	C21967-00	1

## Cabin Pedestal Trainer Mount – C15165-01

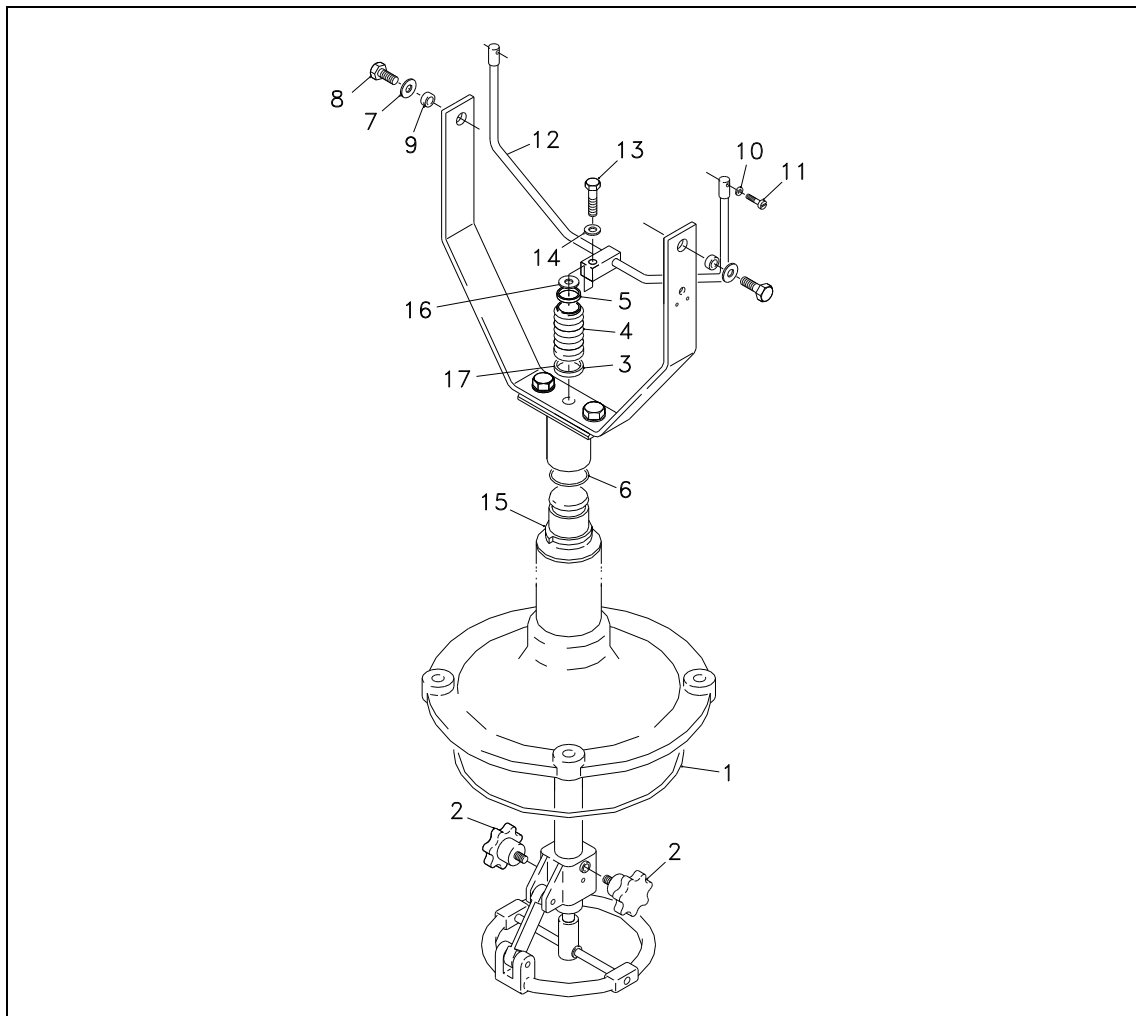

Item No.	Description	Part No.	No. Off
1	'O' Ring Seal Base	C10170-00	1
2	Lock Wheel Assembly	C11026-01	2
3	Bellows Bottom Bush	C20269-01	1
4	Bellows	C20281-00	1
5	Bellows Top Bush	C20270-01	1
6	'O' Ring Seal Spigot	C10169-00	1
7	Washer M10 Plain	C08091-00	2
8	Screw M10 x 20 Button Head	C08094-00	2
9	Trunnion Spacer	C10254-01	2
10	U-Piece Bush	C08932-01	2
11	Screw M6 x 20 Button Head	C10174-00	2
12	U-Piece Assembly	C10086-38	1
13	Screw M8 x 35 Hex Head	C08796-00	1
14	Washer M8 Plain	C06999-00	1
15	Floating Stop	C08929-38	1
16	Washer M12 Plain	C08370-00	1
17	'O' Ring	C21967-00	1

## Seal Kits

Description	Part No.
Deck Gasket Seal Kit	C17110-01
Cabin Gasket Seal Kit	C17089-01
Deck Pedestal Gasket Seal Kit	C17111-01
Cabin Pedestal Gasket Seal Kit	C17112-01

## Spare Parts Ordering

In order to prolong the life and performance of your searchlight it is recommended that only Francis Searchlights Limited spare parts are specified. Reference should be made to the relevant spares section in this manual. The part number should be quoted at all times so that a price and delivery time can be supplied.

Spare parts or accessories can be obtained from your distributor / agent or directly from the manufacturer.

## Parts Disposal

It is essential that all parts are disposed of correctly and safely to ensure no risk to other personnel. When disposing of lamps, the procedures outlined in this manual and the lamp manufacturer's leaflet must be adhered to.

The reworking or modification of parts should not be undertaken before consulting the manufacturer or agent.

## Sales and Service

For sales and service please contact your agent / distributor or contact the manufacturer direct at:

Francis Searchlights Limited  
Union Road  
Bolton  
BL2 2HJ

England

Tel: +44 (0) 1204 558960  
Fax: +44 (0) 1204 558979

E-mail: [sales@francis.co.uk](mailto:sales@francis.co.uk)  
<http://www.francis.co.uk>

## Guarantee

This product is covered with a 12-month warranty. Any claim whilst under warranty should be addressed to the Quality Manager at Francis Searchlights Ltd.

The Manufacturer reserves the right to change the information contained within this booklet without prior notice.



FM 20940

